

# MIDLAND™

7733 Gross Point Road  
Skokie, Illinois 60077  
847-677-0333

## Model A-212-FR10

Vacuum Relief Valve

Mar 15, 2013

(Rev 1)

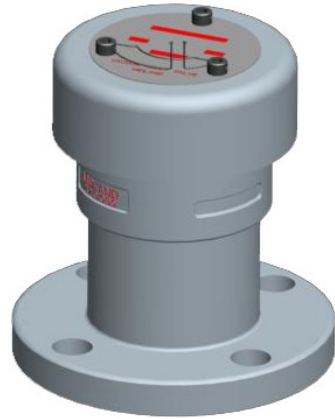

## SPECIFICATION

- All Stainless Steel Construction
- Maximum Operating Temperature: 600°F (depending on elastomer seal)
- Minimum Operating Temperature: -20°F
- Vacuum Settings: 0.75#, 3#, 4# & 5# available
- US Patent : #8,448,663 CA Patent: #2,699,964
- AAR Approval #: E112007
- Options (baffle):

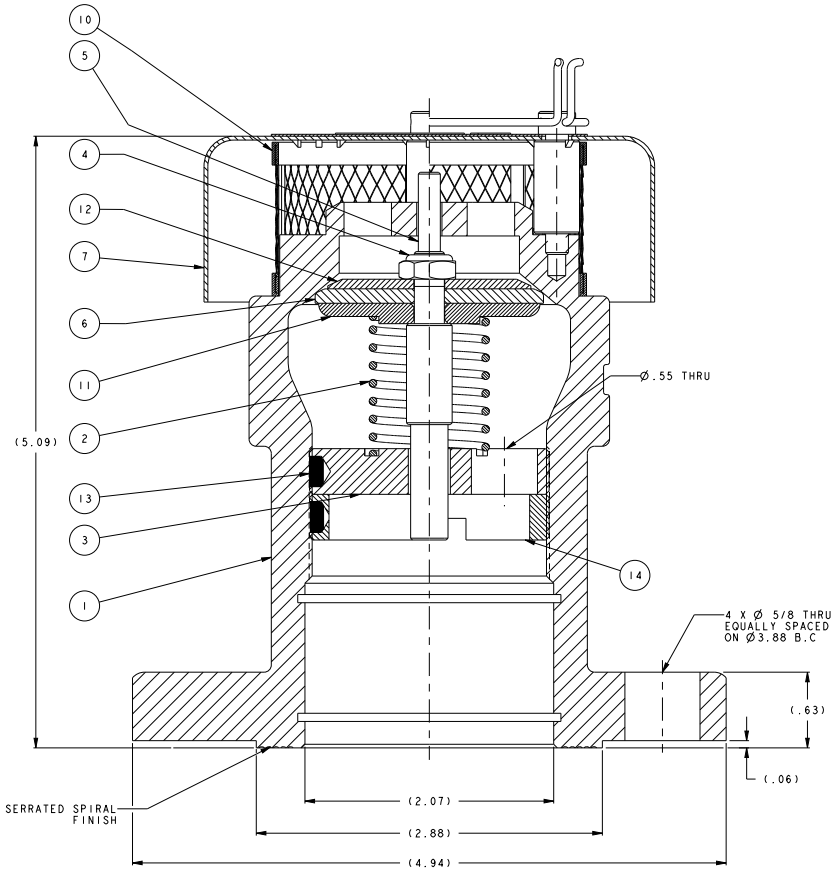

SECTION A-A

ITEM	QTY	PART NAME	A-212-FR10	
			MATERIAL	PART NUMBER
1	1	BODY	STAINLESS	212-010-SS
2	1	SPRING	STAINLESS	207-2-MO
3	1	ADJUSTMENT NUT	STAINLESS	210-03-SS
4	1	LOCKNUT	STAINLESS	210-04-SS
5	1	STEM	STAINLESS	210-05-SS
6	1	SEAL	BUNA N (*)	210-06-BN
7	1	WEATHER CAP ASM	STAINLESS	210-07-SS
8	1	NAMEPLATE	STAINLESS	210-08-SS
9	3	CAP SCREW	STAINLESS	210-09-SS
10	1	FILTER	STAINLESS (*)	210-10-SS
11	1	WASHER	STAINLESS	210-11-SS
12	1	RETAINER	STAINLESS	210-12-SS
13	4	INSERT	PTFE	210-13-TF
14	1	LOCKING RING	STAINLESS	210-140-SS
15	1	SEAL WIRE	STAINLESS / LEAD	22-72-PB

(\*) ALTERNATE MATERIAL CONFIGURATIONS AVAILABLE.