



Vacuum Relief Valve A-210/A-212 Series

Installation, Operation & Maintenance (IOM) Manual

Table of Contents

1	Regulations and Safety Requirements	3
1.1	Regulations	3
1.2	Safety Warnings and Precautions	3
2	Introduction	6
2.1	Technical Specifications	6
2.2	Valve Dimensions	7
2.3	Valve Details – Component Identification and Parts Listings	8
3	Valve Installation.....	10
3.1	Precautions for Mounted-Valve Repair.....	10
3.2	Valve Installation Recommended Tools	10
3.3	Flanged Valve Installation Procedure	10
3.4	Threaded Valve Installation Procedure.....	11
3.5	Leak Inspection.....	11
3.6	Valve Operation Notes and Precautions.....	11
4	Valve Qualification	12
4.1	Valve Disassembly Procedure and Recommended Tools.....	12
4.2	Stem Disassembly Procedure	16
4.3	Component Inspection.....	18
4.4	Valve Reassembly and Recommended Tools.....	22
4.5	Testing Process	28
4.6	Valve-Pressure Testing Procedure.....	28
4.7	Valve-Setting Adjustment Procedure.....	29
4.8	Final Reassembly	30
5	Routine Maintenance.....	33
6	Emergency Response for Leaking Valve.....	33

1 Regulations and Safety Requirements

1.1 Regulations

Midland vacuum relief valves are used in contact with a variety of products, many of which are hazardous materials and could cause serious injury or damage if mishandled. The acceptance and transportation of products are regulated by the DOT and AAR in the U.S.A., and in Canada by CTC and Transport Canada. Regulations of other governmental bodies must be complied with for stationary and mobile applications. All personnel should be familiar with and follow these regulations. Nothing in these instructions is intended to conflict with or supersede these regulations. The information in this document was gathered from knowledgeable sources. However, Midland Manufacturing Corporation makes no representations or guarantees about its accuracy or completeness, and assumes no liability for this information.

Specifications are subject to change without notice.

This valve should only be installed, operated and maintained by qualified personnel. Read all of these instructions carefully before proceeding.

Operation of the valve must conform to all applicable specifications from TC, AAR, DOT, CFR (Parts 173.31, 174.67, etc.) and other governmental bodies, along with the operating instructions of your company.

1.2 Safety Warnings and Precautions

Please carefully read each of the following warnings and cautions prior to performing any work.

WARNING: Toxic Hazard. Always use extreme caution and proper equipment when involved with hazardous materials. To avoid exposure to toxic or hazardous materials, make sure the tank car is empty and clean, and that the work area is free of hazardous chemicals before removing or installing any valve.



- **Wear protective clothing and equipment suitable for withstanding the materials to which you may be exposed**
- **Position yourself on the upwind side of the valve when possible**
- **Work in a well-ventilated area**
- **Work with a partner who can help you in the event of an emergency**
- **Follow approved safety precautions for hazardous or toxic materials**
- **Obtain MSDS sheets for all the commodities used with the associated valve**



WARNING: Spring-Loaded Assembly. During valve-spring disassembly, the valve contains springs under load. **DO NOT** attempt to disassemble the valve without first reading these instructions or injury may result.



CAUTION: Valve-Stem Failure. Cracks and corrosion of vacuum relief valve stems can result in stem failure and uncontrolled venting.



CAUTION: Valve-Stem Straightening. Straightening of the stem by bending it in a press may result in the buildup of uneven stresses in the stem, which may result in valve malfunction.



CAUTION: Valve-Spring Failure. Defects in coil springs, such as cracks and corrosion pits, can act as stress concentrators. Failure to detect these defects can result in coil-spring breakage and uncontrolled valve venting.



NOTICE: Per AAR regulations, as of July 1, 2013, manually activated “Step” vacuum relief valves are prohibited from use on newly built tank cars and from replacement in kind on existing railcars.



NOTICE: Midland manufactures VRVs in various metallic materials with a wide variety of elastomeric seat seals in several sizes and pressure settings available. Exercise care to select the most desirable combination of features for the intended service conditions.



NOTICE: Since the VRVs are frequently small in size, and are set at very low pressures, these valve cannot withstand much abuse. Although the valve’s sole purpose is to permit air from the atmosphere to be introduced into the tank when a negative pressure (of a prescribed amount) occurs in the tank, it has been used incorrectly on occasions to ascertain if positive pressure exists in the tank.



CAUTION: Uneven Gasket Compression. Do not over-tighten the nuts on one side of the valve as this may tilt the valve and result in uneven gasket compression.



NOTICE: Operation of the valve must conform with all applicable TC, AAR, DOT specifications (Parts 173.31, 174.67, etc.), other governmental bodies, and the operating instructions of your company.

NOTICE: The vacuum relief valves are spring-loaded and are actuated by negative pressure in the railcar tank. **There are no provisions for manual activation of the valve.**



NOTICE: To ensure best practice and consistency of your qualification procedure, O-rings, gaskets and wire seals should always be replaced.

Nuts, washers and studs must be closely inspected before re-use or replaced regularly.

Valve components such as the stem, body and spring must be thoroughly inspected.



NOTICE: Valve disassembly should only be done by trained personnel with access to the proper machines, tools, procedures and personal-protective equipment (PPE).



NOTICE: **Without consent from the valve manufacturer or railcar owner,** repair work is limited to cleaning and polishing. See AAR M1002, Paragraph A3.11.1 of the Tank-Car Specifications.



WARNING: Machining Not Allowed. Machining, grinding, welding or other alterations to the valve seat or stem seat is not allowed per AAR M1002, Paragraph A3.11 of the Tank-Car Specifications.



NOTICE: All soft seals need to be replaced at the time of valve qualification.



CAUTION: Safety Protection. Wear appropriate safety glasses or face shield and protective clothing when conducting this procedure. Valve testing involves high-velocity air and water flow that can cause injury.



NOTICE: Maintenance, Scheduled Defined. Scheduled maintenance involves valve inspection and component replacement for valves in-service on tank cars, that is in accordance to the railcar owner's standard qualification and maintenance program, that ensures the valve performs its intended function without failure until its next qualification or for its design life.

NOTICE: Leak Repair Defined. Leak repair is the temporary remediation to a valve observed to be emitting product in an unintended manner. Since leak repair is a temporary measure, once the railcar is unloaded and pressure is relieved, the valve should be removed for complete inspection, repairs, and full requalification in accordance to the railcar owners standard qualification and maintenance program. Leak repair is unscheduled maintenance and is not apart of the scheduled maintenance.



CAUTION: The repair procedure for leaking valves is intended only as a temporary repair to get the railcar to an unloading destination. Once the product is unloaded and pressure is relieved, the valve should be removed for a complete inspection and requalification.

2 Introduction

The Midland Vacuum Relief Valve (VRV) is designed to allow atmospheric air to enter the tank car and protect the tank car from collapse when there is a vacuum condition present. The enhanced valve was designed with a philosophy to keep debris out of valve, relieve vacuum pressure in the tank and avoid the Non-Accident Release (NAR) of the commodity by keeping it safely secured inside the tank.

Features include:

- Optimized for transportation of harsh commodities – including ethanol and crude
- Stainless-steel construction for better corrosion resistance
- No-step design eliminates improper cycling of the valve
- Built-in debris screen keeps contamination from entering the valve-seating area
- Unique seal design eliminates the possibility of using incorrect materials or performing improper installation
 - Seal location helps eliminate “blow outs”
- The poppet on the valve has been reversed, moving the sealing surface away from the lading
- An optional baffle keeps the lading from the sealing surface during product surges
- The stem is guided in two places
 - This reduces accidental cycling or “burping” of the valve
 - Gives the valve a more consistent seal and decreases the risk of pressure leaks
- Vacuum settings from 0.75 psig to 5 psig

2.1 Technical Specifications

VACUUM RELIEF VALVE PART SYSTEM						
STYLE		CONFIGURATION		VACUUM SETTING (PSIG)	SEAL MATERIAL**	
A-21X		-FRXX		-XX	-XX	
2.5" NPT * THREADED	0	BASIC SCREEN W/BAFFLE	1	(NULL = 0.75)	BUNA-N	BN
2.5" FLANGED	2	BASIC SCREEN, NO BAFFLE	10	2	BUNA-N, FOOD GRADE	BNFG
		PREMIUM SCREEN W/BAFFLE	2	3	ETHYLENE PROPYLENE	EP
		PREMIUM SCREEN, NO BAFFLE	20	4	ETHYLENE, PROPYLENE, FOOD GRADE	EPFG
				5	VITON A	VA
					VITON B	VB
* NOTE: Per AAR regulations, effective July 1, 2013, “threaded connection” VRVs are no longer allowed for OEM use on new tank cars.					VITON GL	VL
** NOTE: Contact Midland for additional seal material options.					CHEMRAZ 505	CZ-505

Table 2-1 VRV Part Designation System

2.2 Valve Dimensions

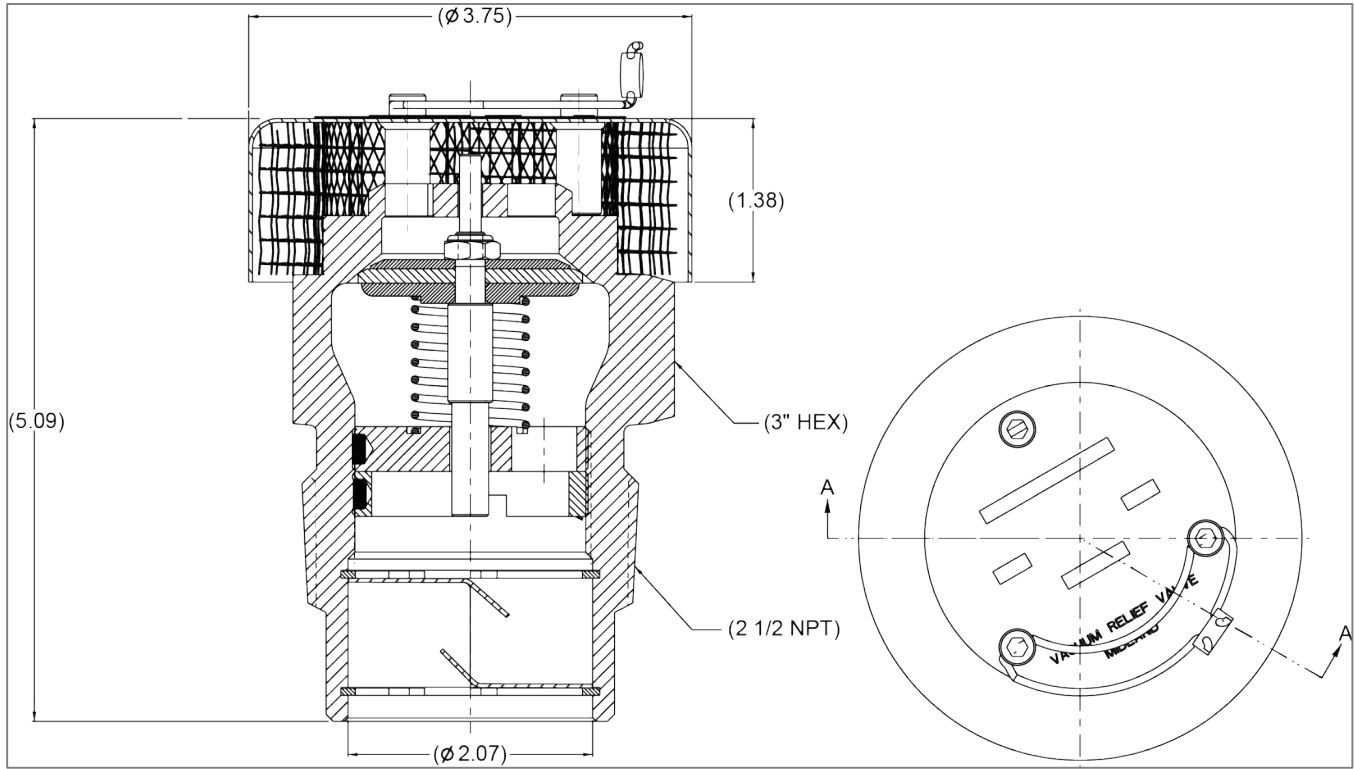

Figure 2-1 A-210-FR2 Dimensions

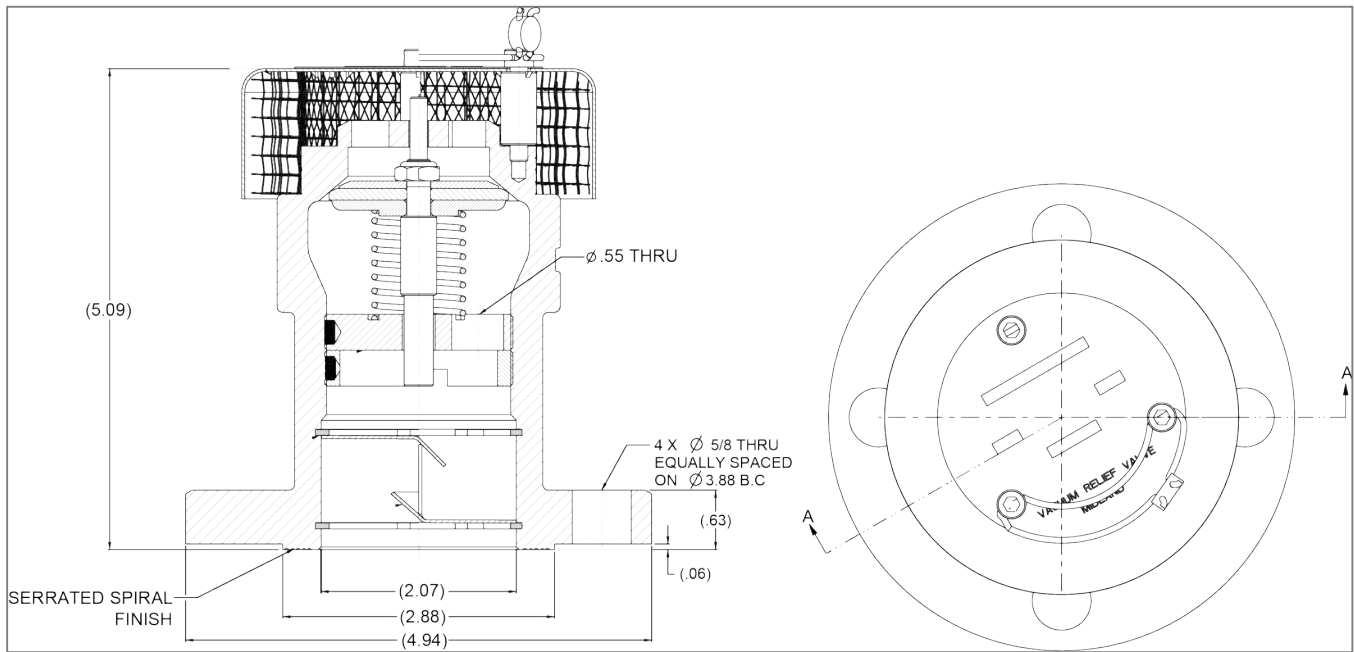

Figure 2-2 A-212-FR2 Dimensions

2.3 Valve Details – Component Identification and Parts Listings

ITEM	QTY.	PART NAME	MATERIAL	A-210 PART NO.	A-212 PART NO.
1	1	Body	Stainless Steel	210-010-SS	212-010-SS
2	1	Spring	Stainless Steel	207-2-MO	207-2-MO
3	1	Adjustment Nut	Stainless Steel	210-03-SS	210-03-SS
4	1	Locknut	Stainless Steel	210-04-SS	210-04-SS
5	1	Stem	Stainless Steel	210-05-SS	210-05-SS
6	1	Seal	Buna-N*	210-06-BN	210-06-BN
7	1	Weather Cap Assembly	Stainless Steel	210-07-SS	210-07-SS
8	1	Name Plate	Stainless Steel	210-08-SS	210-08-SS
9	3	Cap Screw	Stainless Steel	210-09-SS	210-09-SS
10	1	Filter Screen**	Stainless Steel*	210-10-SS	210-10-SS
11	1	Washer	Stainless Steel	210-11-SS	210-11-SS
12	1	Retainer	Stainless Steel	210-12-SS	210-12-SS
13	2	Insert	PTFE	210-13-TF	210-13-TF
14	1	Locking Ring	Stainless Steel	210-140-SS	210-140-SS
15	1	Baffle**	Stainless Steel	210-150-SS	210-150-SS
16/18	2	Retaining Ring	Stainless Steel	210-160-SS	210-160-SS
17	1	Seal Wire	Stainless Steel/Lead	22-72-PB	22-72-PB

* Alternate material configurations available
** Optional item not included on all models

Table 2-2 A-210-FR1 and A-212-FR1 Parts Listing

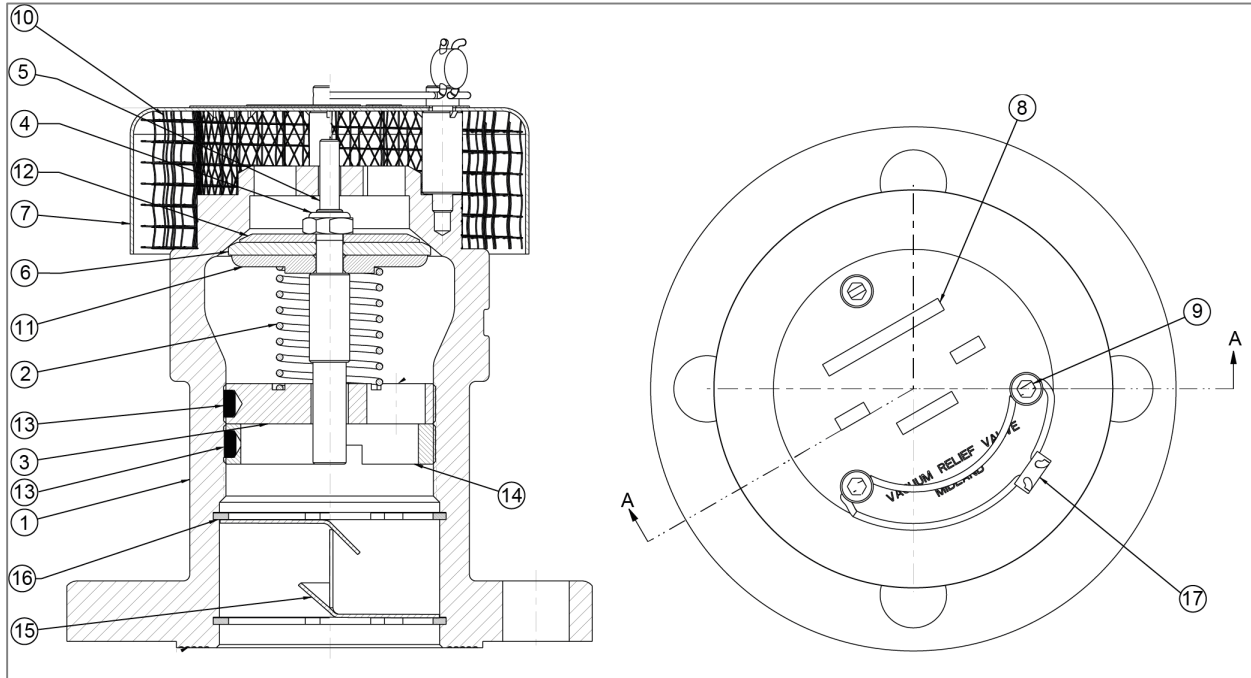

Figure 2-3 A-210-FR1 Component Identification

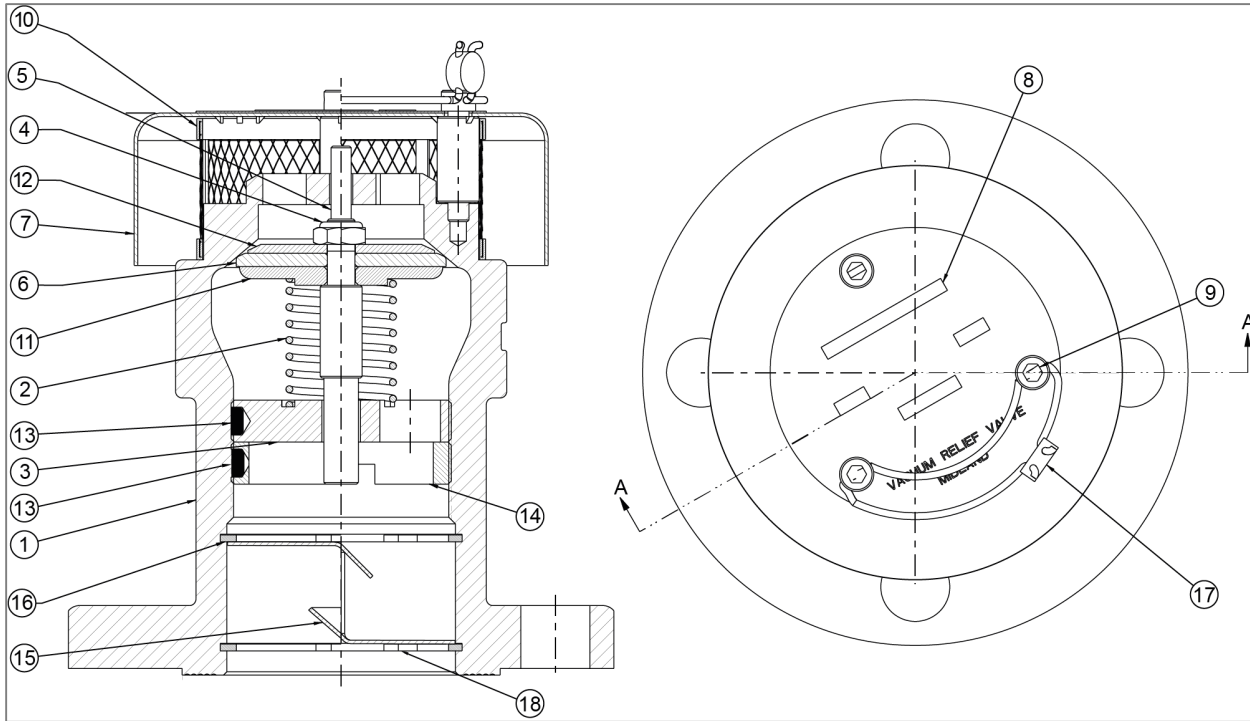

Figure 2-4 A-212-FR1 Component Identification

3 Valve Installation

3.1 Precautions for Mounted-Valve Repair

Prior to installation, ensure that the valve remains clean and the gasket-sealing surfaces are not damaged.



WARNING: When assembling or disassembling the valve, DO NOT position oneself directly in front of the spring and stem. Instead, position oneself to the side away from the valve. Unexpected component failure – valve stem or spring breakage - may cause a sudden energy release discharging component parts a short distance in an uncontrolled manner. Personal injury may be a result.

When performing maintenance on a vacuum relief valve that is mounted on a railcar, observe the following precautions:

- Wear protective clothing and equipment suitable for withstanding the materials to which you may be exposed
- Position yourself on the upwind side of the valve when possible
- Work in a well-ventilated area
- Work with a partner who can help you in the event of an emergency
- Follow approved safety precautions for hazardous or toxic materials
- Obtain MSDS sheets for all the commodities used with the associated valve

3.2 Valve Installation Recommended Tools

SAE Wrench	Component(s)/Description
1-1/4"	Mounting Bolts
Other Tools, Supplies, and Equipment:	
Wire Brush	Rubber Sheet (plug)
Pipe Thread Compound	Gasket (for replacement)
Solvent	Cloth

Table 3-1 Recommended Tools for Valve Installation

3.3 Flanged Valve Installation Procedure

- 3.3.1 Remove the old valve and insert a soft rubber plug into the tank opening. This will prevent debris from entering the tank during cleaning of the valve-mounting groove and studs on the manway cover plate.
- 3.3.2 Using a wire brush, brush the threads of the mounting studs to remove rust or scale. Nuts should move freely on clean studs. Studs should not exhibit excessive corrosion.
- 3.3.3 Remove and discard all used gasket material.
- 3.3.4 Using a cloth and appropriate cleaning solvent, wipe clean the valve and cover-plate sealing surfaces and the mounting-stud threads.
- 3.3.5 Install the new gasket. Ensure it is fully seated.

3.3.6 Position the valve gently into the mounting. Align the body holes over the studs and lower the valve while positioning the valve on the cover-plate.

3.3.7 Install the nuts and tighten them in 1/3-torque increments in a diagonally alternating sequence, as shown in Figure 3-1. Consult gasket manufacturer for recommended torque requirements.



CAUTION: Uneven Gasket Compression. Do not over-tighten the nuts on one side of the valve as this may tilt the valve and result in uneven gasket compression.



TIP: Use a 1-1/4" wrench to tighten mounting nuts; max torque of 100 ft-lb is allowed when installing.

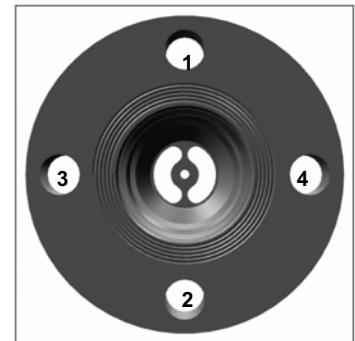

Figure 3-1 Tightening Sequence

3.4 Threaded Valve Installation Procedure

3.4.1 Be sure the threads of the valve and on the tank are clean and serviceable. Using a wire brush, brush the threads of the coverplate to remove rust or scale.

3.4.2 Use sealing compound to lubricate the valve threads to facilitate getting a good pressure-tight seal.



CAUTION: Do not use a large pipe wrench to install the valve. Care should be taken not to distort the valve body's internal seat.

Do not wrench on the valve stem or weather cap. They are unable to sustain much torque.

3.4.3 Thread the valve onto an appropriately-sized threaded male nipple and tighten.

3.5 Leak Inspection

3.5.1 Test all newly installed valves under pressure to confirm that no leaks are present.



WARNING: Valve Leakage. Improper valve seating, loose nuts and damaged gaskets may result in leaks at the valve-mounting joint.

3.6 Valve Operation Notes and Precautions



NOTICE: Operation of the valve must conform with all applicable TC, AAR, DOT specifications (Parts 173.31, 174.67, etc.), other governmental bodies, and the operating instructions of your company.

NOTICE: The vacuum relief valves are spring-loaded and are actuated by negative pressure in the railcar tank. **There are no provisions for manual activation of the valve.**

4 Valve Qualification



NOTICE

NOTICE: To ensure best practice and consistency of your qualification procedure, O-rings, gaskets and wire seals should always be replaced.

Nuts, washers and studs must be closely inspected before re-use or replaced regularly.

Valve components such as the stem, retainer, body and spring must be thoroughly inspected.

4.1 Valve Disassembly Procedure and Recommended Tools

SAE Wrench	Component(s)/Description	Torque (in-lb)
5/32"	Hex-Head Wrench [for Cap Screws (item 9)]	–
7/16"	Wrench	–
Other Tools, Supplies, and Equipment:		
Snap-Ring Pliers		
Wire Cutter		

Table 4-1 Recommended Tools for Valve Disassembly



NOTICE

NOTICE: Valve disassembly should only be done by trained personnel with access to the proper machines, tools, procedures and personal-protective equipment (PPE).



CAUTION

CAUTION: Spring-loaded Assembly. During valve-spring disassembly, the valve contains springs under load. DO NOT attempt to disassemble the valve without first reading these instructions or injury may result.



NOTICE

NOTICE: Please note that following instructions are based on the A-212-FR1 VRV model. Your specific valve model may vary from configuration shown; however, valve-disassembly procedure will be the similar.

4.1.1 Remove wire seal (item 17).



Figure 4-1 Remove Wire Seal

4.1.2 Remove the three (x3) cap screws (item 9).



TIP: Use a 5/32" hex-head wrench.

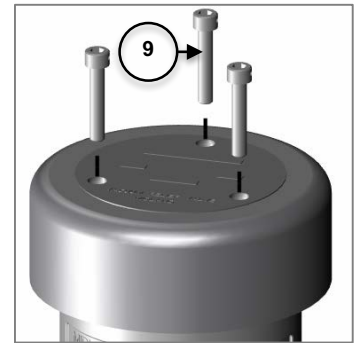

Figure 4-2 Remove Screws

4.1.3 Remove the weather cap (item 7).

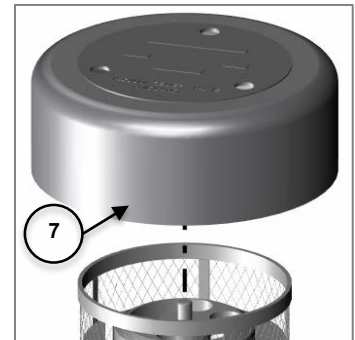

Figure 4-3 Remove Weather Cap

4.1.4 Remove the filter (item 10). (Optional part not included in all assemblies.)

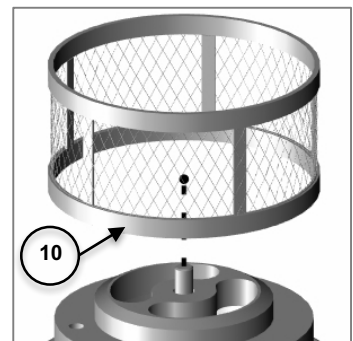

Figure 4-4 Remove Filter (Optional)

4.1.5 Flip the valve over and remove the (optional) lower retaining ring (item 18).



TIP: Use snap-ring pliers.

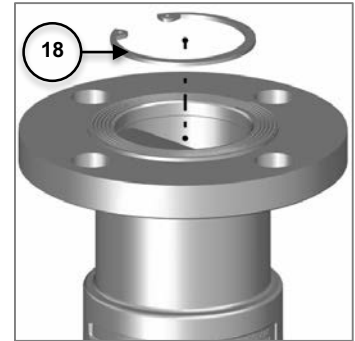

Figure 4-5 Remove Lower Ring

4.1.6 Remove the baffle insert (item 15). (Optional part not included in all assemblies.)

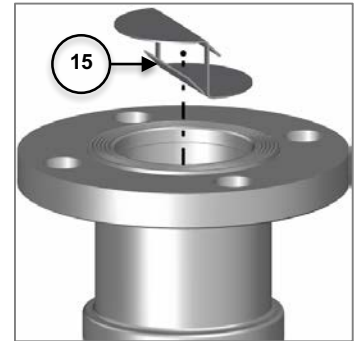

Figure 4-6 Remove Baffle (Optional)

4.1.7 Remove the upper retaining ring (item 16).



TIP: Use snap-ring pliers.

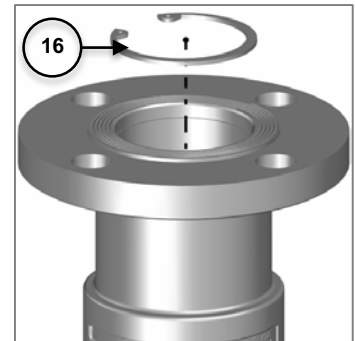

Figure 4-7 Remove Upper Ring

4.1.8 Loosen and remove the locking ring (item 14) with PTFE insert (item 13).

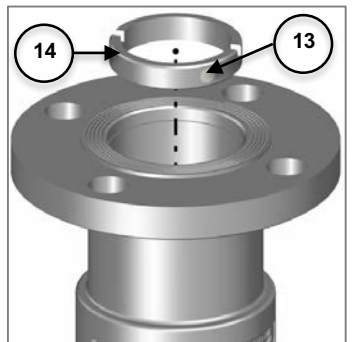

Figure 4-8 Remove Locking Ring

4.1.9 Loosen and remove the adjustment nut (item 3) with PTFE insert (item 13).

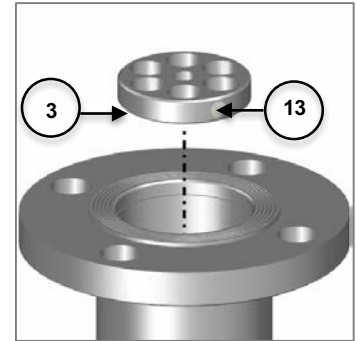

Figure 4-9 Remove Adjustment Nut

4.1.10 Remove the spring (item 2).

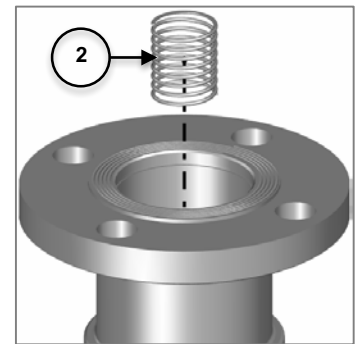

Figure 4-10 Remove Spring

4.1.12 Remove the stem assembly (items 4, 5, 6, 11, and 12).

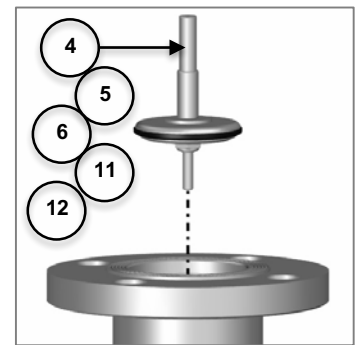

Figure 4-11 Remove Assembly

4.2 Stem Disassembly Procedure



NOTICE: If your company has an approved component cleaning and inspection procedure, follow it. If it does not, follow the processes and procedures set in this manual for valve component cleaning, inspection and, if necessary, replacement. Reassemble the valve per Section 1.1 of this manual.



Figure 4-12 Stem Assembly

4.2.1 Loosen and remove the stem assembly locknut (item 4).



TIP: Use a 7/16" socket and wrench.

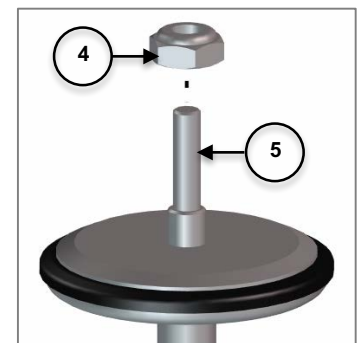

Figure 4-13 Remove Pressure Seal

4.2.2 Remove the retainer (item 12) from the stem (item 5).



Figure 4-14 Remove Retainer

4.2.3 Remove the seal (item 6) from the stem (item 5).

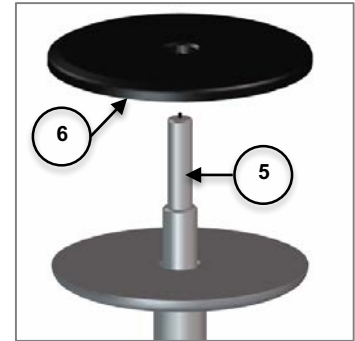

Figure 4-15 Remove Seal

4.2.4 Remove the washer (item 11) from the stem (item 5).

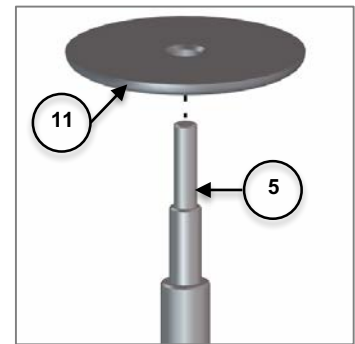

Figure 4-16 Remove Washer

4.3 Component Inspection

Key components must be thoroughly inspected during the qualification process. These components include the stem, valve body, spring and pressure seal.

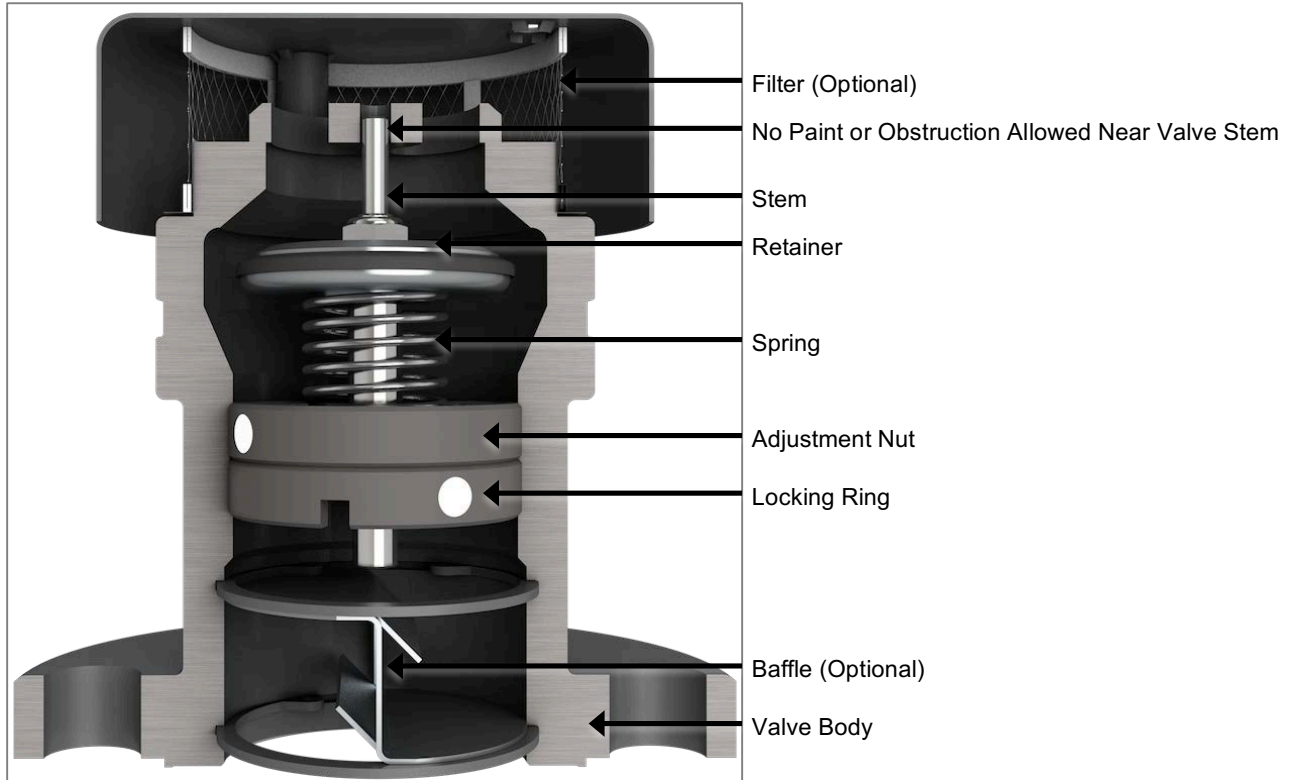

Figure 4-17 Valve-Inspection Points

While the soft seals must always be replaced during this step, Midland also suggests that the nuts, washers and studs be regularly replaced during the qualification process.



NOTICE: Procedures may not cover all conditions encountered in the field. Therefore, it is the responsibility of the repair agency to obtain approval from Midland for inspection, evaluation, repair and maintenance procedures not covered herein. Evaluation of critical component metal surfaces of the valves after cleaning, inspection and specialized testing performed by agencies other than the repair facility are the responsibility of the repair facility. Where numerical tolerances cannot be provided, the disposition of the internal integrity and surface quality of parts is under the jurisdiction of the repair facility and dependent on its experience and judgment.



NOTICE: Without consent from the valve manufacturer or railcar owner, repair work is limited to cleaning and polishing. See AAR M1002, Paragraph A3.11.1 of the Tank-Car Specifications.



NOTICE: During component inspection, valve components can be cleaned with a suitable solvent and cloth and minor surface defects buffed with 400-grit sandpaper.

4.3.1 Valve Body Inspection

4.3.1.1 Top Stem Guide Inspection

The body (item 1) is a structural part. There should be no paint on the top guide section of this part where the valve stem enters it. The area of discharge through the body must be unobstructed by foreign matter that would hinder free flow of discharging fluid.

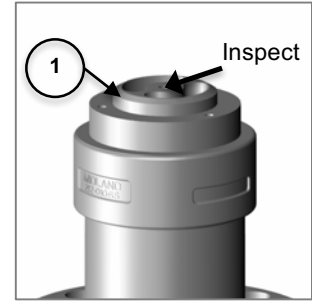

Figure 4-18 Inspect Top Stem Guide

4.3.1.2 Seat/Seal Area Inspection

Inspect and clean seat area. No corrosion is allowed in the sealing areas of the VRV body seat. Light corrosion is allowed on the other surfaces as long as the light corrosion does not cause destruction of the material or impede intended performance of the valve. If there are any nicks, mars, corrosion or any other visible damage to the seal area, the part is rejectable and should be replaced.

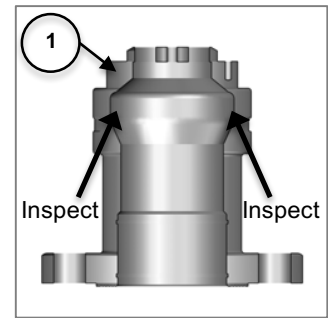

Figure 4-19 Inspect Seat/Seal Area

4.3.1.3 Threaded Section Inspection

Threads should be cleaned with a cloth and suitable solvent to remove any dirt or particles and inspected to ensure proper mating with adjusting and locking rings. Inspect threads for any sign of excessive wear, corrosion, pitting or other defects. If any are found, the part is rejectable and should be replaced.

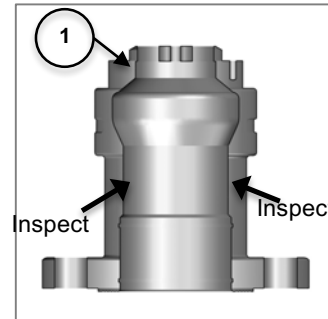

Figure 4-20 Inspect Threaded Section

4.3.1.4 Sealing Surface Inspection (Valve Mounting)

On the underside of the valve body (item 1) is the surface that seals the valve to the mounting plate on the railcar. A good seating surface is necessary to ensure there are no leaks in this area. If there are any nicks, marks, pitting or any other visible damage to the seal area, the part is rejectable and should be replaced. Light corrosion is acceptable as long as the correction does not impede the sealing of the valve.

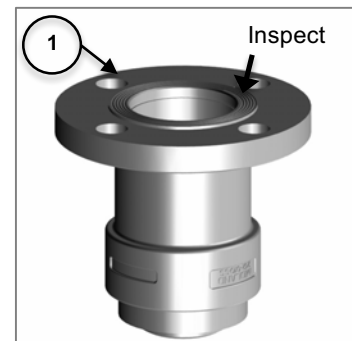

Figure 4-21 Inspect Sealing Surface

4.3.2 Filter Inspection (Optional item not included in all assemblies)

The filter (item 10) should be inspected to be free of any obstructions to airflow. Remove all contaminants as needed. If filter has any defects that would allow large item into the valve, the filter should be replaced.

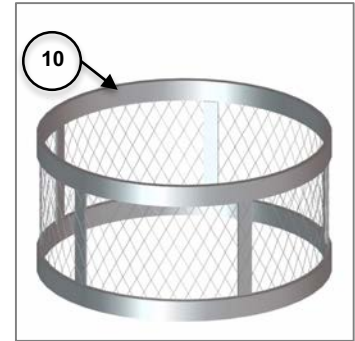

Figure 4-22 Inspect Filter

4.3.3 Adjustment Nut and Locking Ring Inspection

Clean to remove any dirt or particles and inspect the threads around the entire circumference of the adjustment nut (item 3) and locking ring (item 14) for any nicks or damage. Be aware that any chipped, missing or damaged plating is an indication that the component should be replaced. Inspect threads for any sign of excessive wear, corrosion, pitting or other defects. If any are found, the part is rejectable and should be replaced.

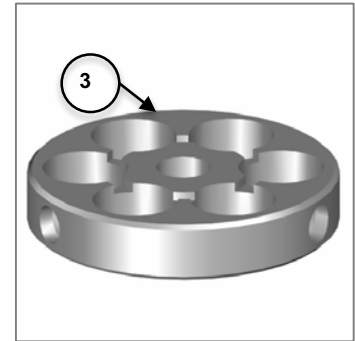

Figure 4-23 Inspect Adjustment Nut

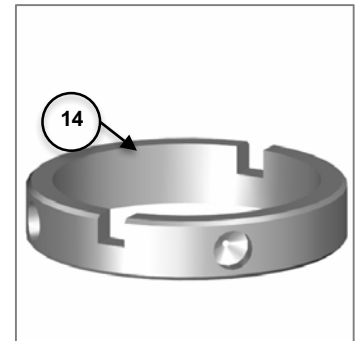

Figure 4-24 Inspect Locking Ring

4.3.4 Spring Inspection

Inspect the spring (item 2) for corrosion, pitting and cracks. The spring should be replaced if there is any sign of corrosion, pitting or cracks.

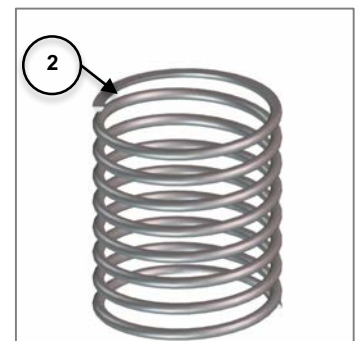

Figure 4-25 Inspect Spring

4.3.5 Stem Assembly Inspection

Remove scale, residual product and other foreign material from the stem.



CAUTION: Check for Cracks. Cracks are stress concentrators and can cause catastrophic failure of the stem and uncontrolled venting.

Inspect the stem threads and seat area for any nicks, marks or cracks.

Also, inspect for corrosion pitting. Any corrosion pitting is reason for rejection since it may indicate more severe corrosion and the starting point for difficult-to-detect cracking.

If any defects are found, the stem is rejectable and should be replaced.

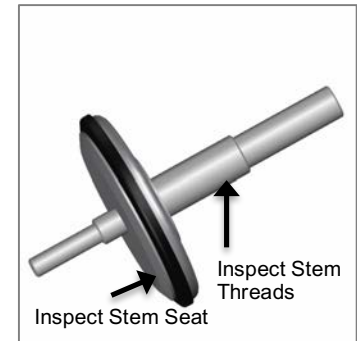

Figure 4-26 Inspect Stem Assembly

4.3.6 Valve Seal Inspection

The valve seal (item 6) should be inspected and recorded.



NOTICE: All soft seals need to be replaced at the time of valve qualification.

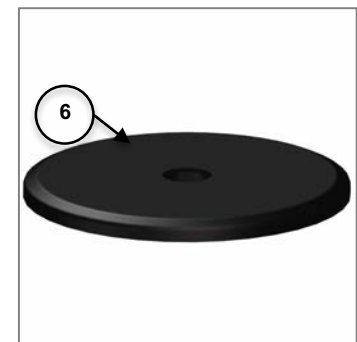

Figure 4-27 Inspect Pressure Seal

4.3.7 Special Inspection Considerations

- 4.3.7.1 Previous procedures may not cover all conditions encountered in the field. Therefore, it is the responsibility of the repair agency to obtain approval from Midland for inspection, evaluation, repair and maintenance procedures not covered herein.
- 4.3.7.2 Evaluation of critical component metal surfaces of the valves after cleaning, inspection and specialized testing performed by agencies other than the repair facility are the responsibility of the repair facility
- 4.3.7.3 Where numerical tolerances cannot be provided, the disposition of the internal integrity and surface quality of parts is under the jurisdiction of the repair facility and dependent on its experience and judgment.

4.4 Valve Reassembly and Recommended Tools

SAE Wrench	Component/Description	Torque (in-lb)
7/16"	Torque Wrench (for Stem Assembly)	10
5/32"	Hex-Head Wrench [for Cap Screws (item 9)]	–
7/16"	Wrench	–
Other Tools, Supplies, and Equipment:		
Snap-Ring Pliers		
Grease (Krytox GPL 204 or equivalent)		

Table 4-2 Recommended Tools for Valve Reassembly

Valve reassembly will require replacement parts (available from Midland) for discarded soft parts as part of proper qualification.

Item #	Component/Description	Qty.
13	Insert	2
6	Seal	1

Table 4-3 Replacement Parts for Valve Reassembly

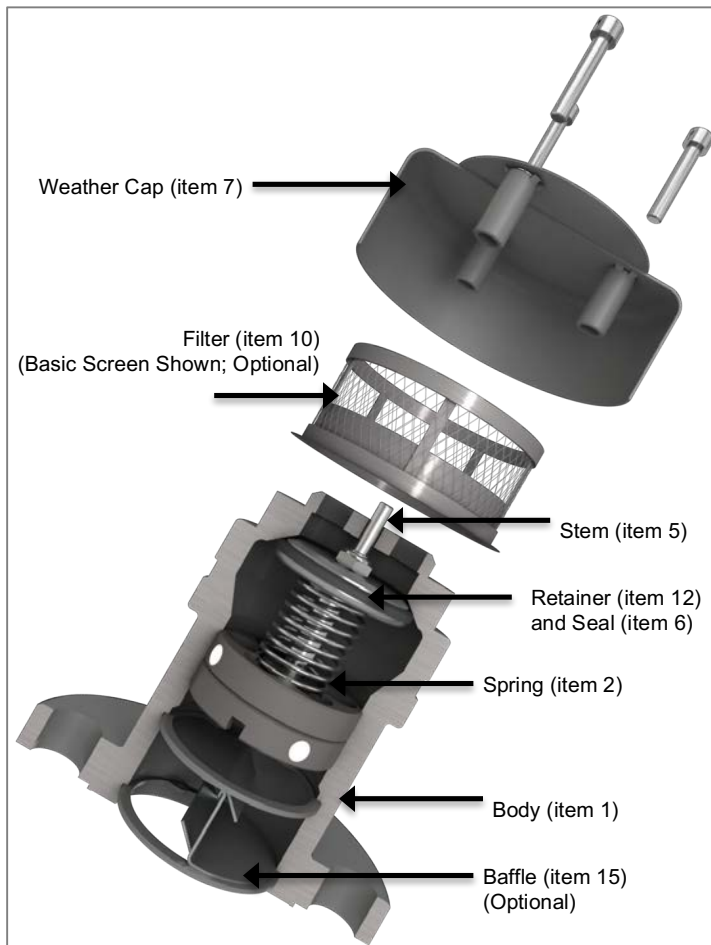

Figure 4-28 Valve Exploded View

4.4.1 Stem Reassembly

The stem assembly includes the following five components.

- Retainer (item 12)
- Pressure Seal (item 6)
- Washer (item 11)
- Locknut (item 4)
- Stem (item 5)

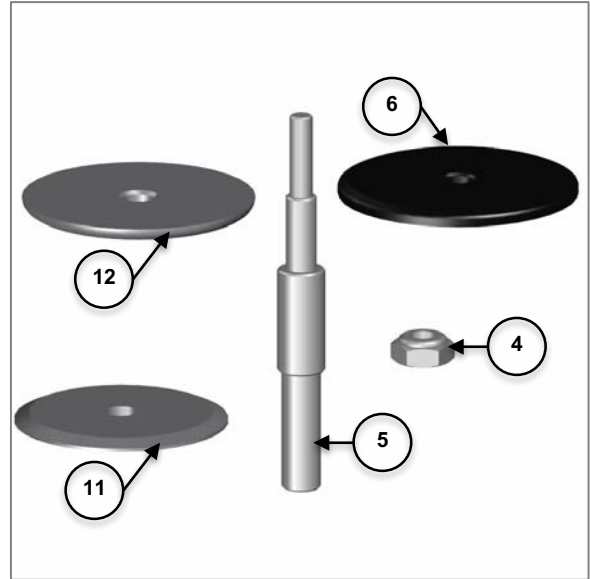

Figure 4-29 Stem Assembly Components

- 4.4.1.1 Place the washer (item 11) onto the stem (item 5) with the curved side placed downward.

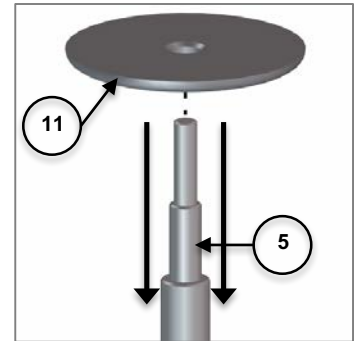

Figure 4-30 Place Washer on Stem

- 4.4.1.2 Place the seal (item 6) onto stem (item 5) over the washer (item 11).

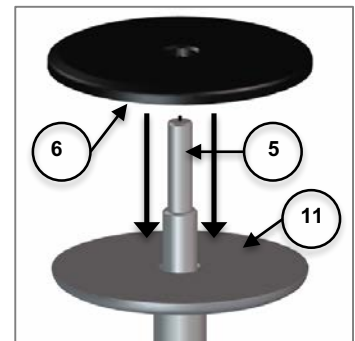

Figure 4-31 Place Seal on Stem

4.4.1.3 Place the retainer (item 12) onto stem (item 5) over the seal (item 6) with the beveled side placed upward.

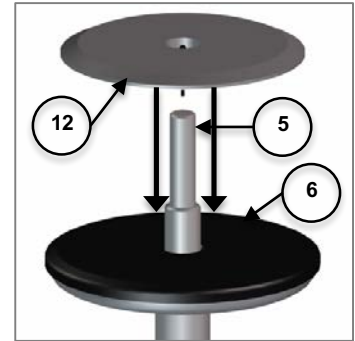

Figure 4-32 Place Retainer on Stem

4.4.1.4 Place the locknut (item 4) onto stem (item 5) over the retainer (item 12) using a wrench to secure the fastener down, but do not tighten, then secure flush with the retainer.



TIP: Use a 7/16" wrench to secure, but do not tighten.

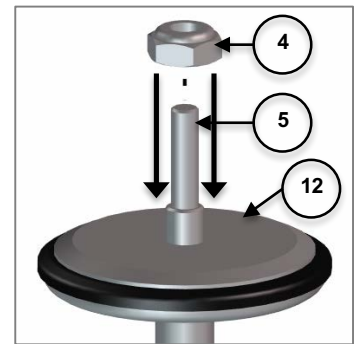

Figure 4-33 Place Locknut on Stem

4.4.1.5 Tighten locknut (item 4) to the required 10 in-lb.



TIP: Use a 7/16" socket and torque wrench to tighten.



Figure 4-34 Tighten Locknut

4.4.2 Body Preparation Prior to Reassembly

4.4.2.1 Clean and blow away any debris or dirt from the body (item 1).



Figure 4-35 Clean Valve Body

4.4.2.2 Apply grease around the inner diameter threads of the body (item 1).



TIP: Apply grease (Krytox GPL 204 or equivalent) to inner diameter threads.

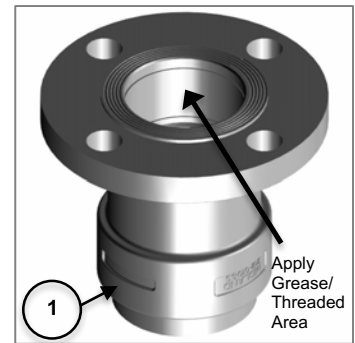

Figure 4-36 Apply Grease to Inner Threads

4.4.2.3 Carefully secure the valve body (item 1) for reassembly process.

4.4.3 Body and Stem Reassembly Procedure

4.4.3.1 Carefully place stem (item 5) assembly into body (item 1) making sure that the tip of the stem (item 5) centers in the hole at the top of the body.

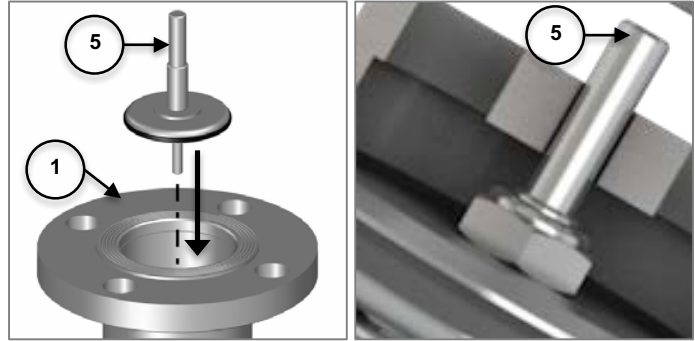

Figure 4-37 Place Stem Assembly Centered in Body Hole

4.4.3.2 Carefully place the spring (item 2) into the body (item 1).

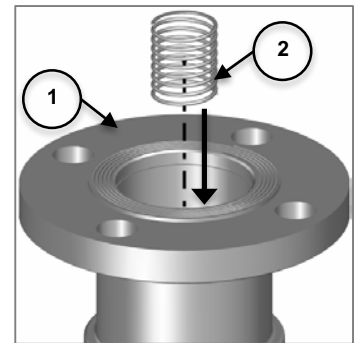

Figure 4-38 Place Spring

4.4.3.3 Carefully press PTFE insert (item 13) into the adjustment nut (item 3) then apply the grease around the threads.



TIP: Apply grease (Krytox GPL 204 or equivalent) around threads.



Figure 4-39 Place PTFE Inserts into Adjustment Nut

4.4.3.4 Install adjustment nut (item 3) by threading the adjustment nut inside the body (item 1) groove facing downward.



NOTICE: Groove side of the adjustment nut (item 3) goes face down toward the spring; it keeps the spring centered during installment (see Figure 4-42).

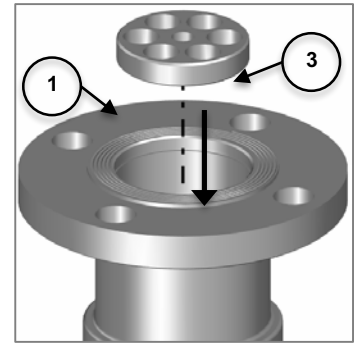

Figure 4-40 Install Adjustment Nut (Grooves Facing Downward)

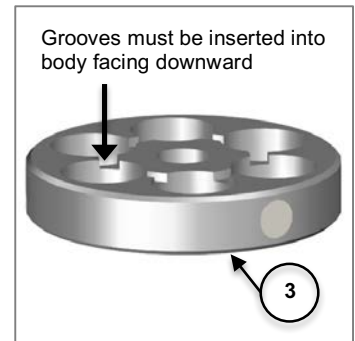

Figure 4-41 Adjustment Nut Grooves Facing Downward



NOTICE: For initial assembly, the stem (item 5) should protrude approximately 1/4" above the adjustment nut (item 3).

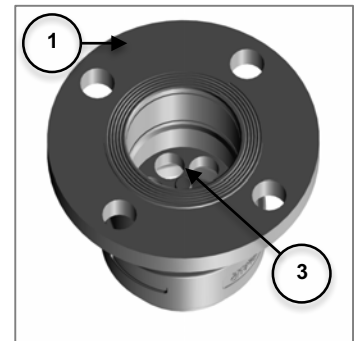

Figure 4-42 Fasten Adjustment Nut



NOTICE: At this reassembly stage, the valve should be vacuum tested in accordance with appropriate regulations with Sections 4.5 of this manual as a guide.

4.5 Testing Process

4.5.1 Special Guidelines & Precautions on Pressure Testing & Adjustment



CAUTION: Safety Protection. Wear appropriate safety glasses or face shield and protective clothing when conducting this procedure. Valve testing involves high-velocity air and water flow that can cause injury.

Refer to AAR publication "Regulations for Tank Cars." Appendix A applies specifically to valves. This section prescribes the start-to-open pressure (STO), the bubble-tight pressure and their tolerances.

4.5.2 Test Stand and Gauge Requirements

It is recommended that the test-stand mounting must be equivalent to the AAR M1002 figures E19.14 through E19.23 for the valve being tested. The pressure gauge must meet the requirements of D4.5 Test Gauge Standards and must be date-tagged.

4.6 Valve-Pressure Testing Procedure

If your company has an approved test procedure, follow it. If it does not, these procedures provide essential guidelines in regard to testing.

4.6.1 Initial Setup

4.6.1.1 Install the valve on the test fixture.

4.6.1.2 Clamp the valve under pressure.

4.6.1.3 Take a position allowing observation of the pressure gauge and bubbling of air in the valve seat.

4.6.2 Positive-Pressure (Bubble-Leak) Test

4.6.2.1 Apply 165 psig of pressure slowly to the inlet of the valve. Check for any bubbles. Bubbles could indicate the valve's inability to sustain pressure over time and could be an indication of a valve body defect.

4.6.2.2 After testing the valve, close the pressure inlet valve to the test chamber, vent the pressure in the test stand. Remove the valve from the test fixture.

4.6.2.3 Wipe or blow away any remaining soapsuds and water used in the testing.

4.6.3 Vacuum Test

- 4.6.3.1 Place valve into fixture for final vacuum pressure test.
- 4.6.3.2 Secure the valve completely.
- 4.6.3.3 Increase vacuum until the valve opens. Make note of the setting at which the stem releases from the valve seat.
- 4.6.3.4 Decrease vacuum until the valve closes. Make note of the valve closure setting.
- 4.6.3.5 Set pressure has a minimum and maximum range where the stem should release as indicated on the provided chart. If the valve passes the test, release the pressure and remove the valve.

Set Pressure (psig) – Vacuum	Tolerance Range (psig)	Vapor Tight (psig) – Vacuum
#	OPEN	CLOSED
0.75	0.75 – 1.50	0.50
1.00	1.00 – 1.75	0.50
1.50	1.00 – 2.00	0.75
2.00	1.50 – 2.50	1.00
3.00	2.50 – 3.50	1.50
4.00	3.50 – 4.50	2.00
5.00	4.50 – 5.50	3.50
10.00	9.00 – 11.00	7.00

Table 4-4 Vacuum Pressure Test Settings

- 4.6.3.6 Proceed to Section 4.7 Final Reassembly procedure.

4.7 Valve-Setting Adjustment Procedure

- 4.7.1 Before final assembly, the valve's set pressure is adjusted by turning the threaded adjustment nut (item 3) inside the valve body (item 1).
- 4.7.2 With the valve bottom-side-up, turn the adjustment nut (item 3) clockwise to increase the setting (higher vacuum) and counterclockwise to decrease the setting.
- 4.7.3 Post-Test Procedure
 - 4.7.3.1 After testing the valve, close the pressure inlet valve to the test chamber, vent the pressure in the test stand. Remove the valve from the test fixture.
 - 4.7.3.2 Wipe or blow away any remaining soapsuds and water used in the testing.

4.8 Final Reassembly

4.8.1 Press in the PTFE insert (item 13) into the locking ring (item 14).

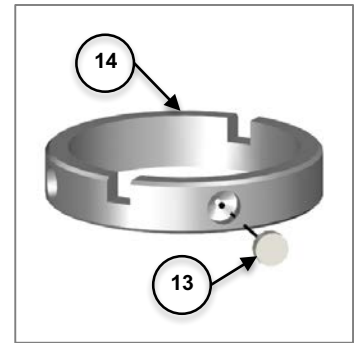

Figure 4-43 Place PTFE Inserts into Locking Ring

4.8.2 Apply grease around the thread of the locking ring (item 14).



TIP: Apply grease (Krytox GPL 204 or equivalent) around threads.

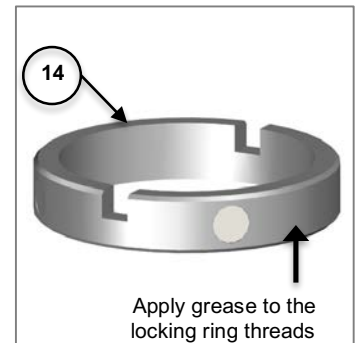

Figure 4-44 Apply Grease to Threads

4.8.3 Install locking ring (item 14) grooves up towards the opening of the valve body (item 1).

Secure locking ring (item 14) until it is tight against the adjustment nut (item 3).

Tighten locking ring (item 14) and adjustment nut (item 3) to secure properly.



TIP: Torque to 10 in-lb.

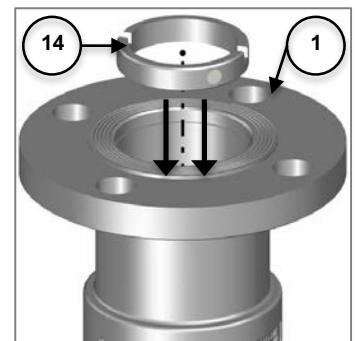

Figure 4-45 Install Locking Ring

4.8.4 Place valve into vise and proceed to install retaining ring (item 16) into the bottom groove of the body (item 1).

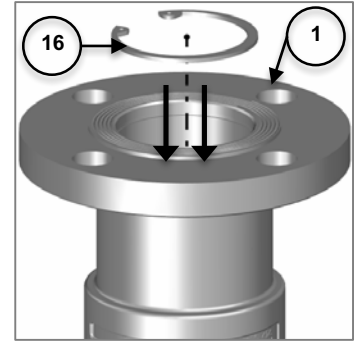

Figure 4-46 Install Retaining Ring

4.8.5 Insert baffle (item 15) into body (item 1). (Optional part not included in all assemblies.)

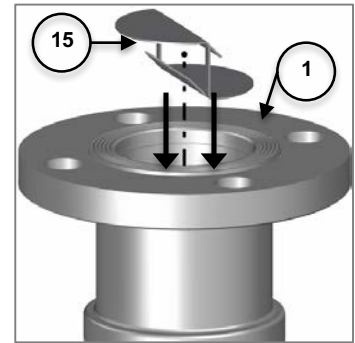

Figure 4-47 Install Baffle (Optional)

4.8.6 Secure the second retaining ring (item 18) into the top groove. (Optional part not included in all assemblies.)

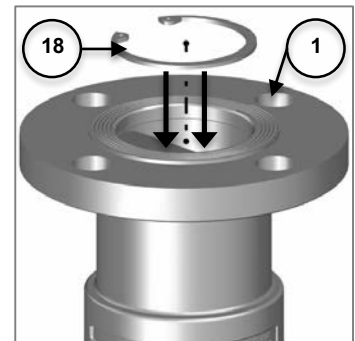

Figure 4-48 Install Second Retaining Ring

4.8.7 Place the valve on a table, and install the filter (item 10). (Optional part not included in all assemblies.)

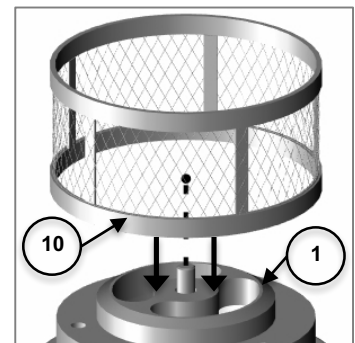

Figure 4-49 Install Filter (Optional)

4.8.8 Install the weather cap (item 7) on to the body (item 1).

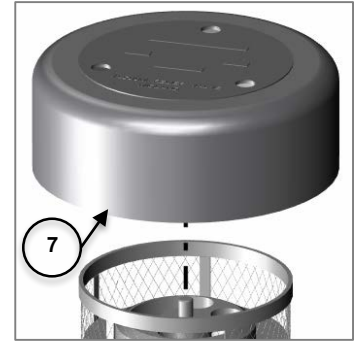

Figure 4-50 Install Weather Cap

4.8.9 Secure the weather cap (item 7) by installing and tightening the three (x3) cap screws (item 9).



TIP: Use a 5/32" hex-head wrench to tighten.

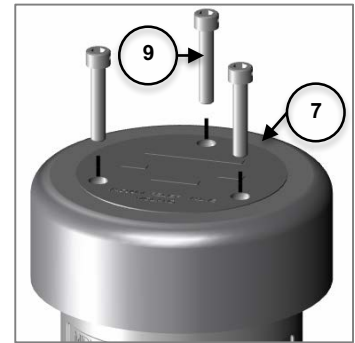

Figure 4-51 Install Cap Screws

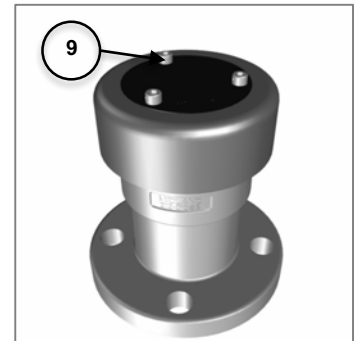

Figure 4-52 Tighten Cap Screws

4.8.10 Install seal wire and lead (item 17), then twist and tighten wire. Crimp lead insert and cut excess wire.



Figure 4-53 Install Seal Wire and Lead

5 Routine Maintenance



NOTICE

NOTICE: Maintenance, Scheduled Defined. Scheduled maintenance involves valve inspection and component replacement for valves in-service on tank cars, that is in accordance to the railcar owner's standard qualification and maintenance program, that ensures the valve performs its intended function without failure until its next qualification or for its design life.

NOTICE: Leak Repair Defined. Leak repair is the temporary remediation to a valve observed to be emitting product in an unintended manner. Since leak repair is a temporary measure, once the railcar is unloaded and pressure is relieved, the valve should be removed for complete inspection, repairs, and full requalification in accordance to the railcar owners standard qualification and maintenance program. Leak repair is unscheduled maintenance and is not apart of the scheduled maintenance.



CAUTION

CAUTION: The repair procedure for leaking valves is intended only as a temporary repair to get the railcar to an unloading destination. Once the product is unloaded and pressure is relieved, the valve should be removed for a complete inspection and requalification.

6 Emergency Response for Leaking Valve



NOTICE

NOTICE: Emergency Response is the temporary remediation to a valve observed to be emitting product in an unintended manner. Since leak repair is a temporary measure, once the railcar is unloaded and pressure is relieved, the valve should be removed for complete inspection, repairs, and full qualification in accordance to the railcar owner's standard qualification and maintenance program. Leak repair is unscheduled maintenance and is not part of scheduled maintenance.

