



**DEFINING | WHAT'S NEXT**

# Top-Transfer 2" Angle Valve

A-720, A-721 and A-724 Series

**Installation, Operation  
& Maintenance Manual**



Part No.: A-720/A-721/A-721-B/A-724, Rev. 1.9  
Issue Date: Sep 10, 2024  
Supersedes: A-720/A-721/A-721-B/A-724, Rev. 1.8

[www.midland.com](http://www.midland.com)

<b>SECTION 1   REGULATIONS AND SAFETY REQUIREMENTS.....</b>	<b>3</b>
1.1 Regulations.....	3
1.2 Safety Warnings and Precautions.....	3
<b>SECTION 2   INTRODUCTION.....</b>	<b>4</b>
2.1 Component Identification and Parts Listings .....	4
<b>SECTION 3   VALVE INSTALLATION.....</b>	<b>8</b>
3.1 Installation and Required Tools .....	8
<b>SECTION 4   OPERATING PROCEDURE.....</b>	<b>10</b>
4.1 Opening the Valve .....	10
<b>SECTION 5   VALVE QUALIFICATION .....</b>	<b>11</b>
<b>SECTION 6   VALVE DISASSEMBLY .....</b>	<b>15</b>
<b>SECTION 7   VALVE REASSEMBLY AND TESTING PROCEDURES .....</b>	<b>19</b>
7.1 Cleaning.....	19
7.2 Reassembly Procedure .....	19
7.3 Testing Procedure.....	25
7.4 Post-Test Procedures .....	25
<b>SECTION 8   MAINTENANCE.....</b>	<b>26</b>
8.1 Prior to Maintenance Tasks Performed .....	26
8.2 Leak Repair on a Mounted Valve .....	26

# 1 REGULATIONS AND SAFETY REQUIREMENTS

## 1.1 REGULATIONS

Midland angle valves are used in contact with a variety of products, many of which are hazardous materials. The acceptance and transportation of products are regulated by the DOT and AAR in the U.S.A., and in Canada by CTC and Transport Canada. Regulations of other governmental bodies must be complied with for stationary and mobile applications. All personnel should be familiar with and follow these regulations. Nothing in these instructions is intended to conflict with or supersede these regulations. The information in this document was gathered from knowledgeable sources. However, Midland Manufacturing Corporation makes no representations or guarantees about its accuracy or completeness, and assumes no liability for this information.

Specifications are subject to change without notice.

Midland valves are used in connection with a variety of products, many of which are hazardous materials and could cause serious injury or damage if mishandled. This valve should only be installed, operated and maintained by qualified personnel. Read all of these instructions carefully before proceeding.

Operation of the valve must conform to all applicable specifications from TC, AAR, DOT, CFR (Parts 173.31, 174.67, etc.) and other governmental bodies, along with the operating instructions of your company.

## 1.2 SAFETY WARNINGS AND PRECAUTIONS

Please carefully read each of the following warnings and cautions prior to performing any work.



**WARNING: Toxic Hazard.** Always use extreme caution and proper equipment when involved with hazardous materials. To avoid exposure to toxic or hazardous materials, make sure the tank car is empty and clean, and that the work area is free of hazardous chemicals before removing or installing any valve.

- Wear protective clothing and equipment suitable for withstanding the materials to which you may be exposed
- Position yourself on the upwind side of the valve when possible
- Work in a well-ventilated area
- Work with a partner who can help you in the event of an emergency
- Follow approved safety precautions for hazardous or toxic materials
- Obtain MSDS sheets for all the commodities used with the associated valve



**CAUTION: Valve Leakage.** Loose nuts and damaged gaskets may result in leaks at the valve-mounting joint.



**CAUTION: Sealing Surface Damage.** A damaged sealing surface on the valve flange may prevent proper sealing on the tank-car mounting and result in leakage of the tank contents.

## 2 INTRODUCTION

Tank cars equipped with the Midland A-720, A-721, A-721-B and A-724 Series Top-Transfer Angle Valves offer long-term reliability and ease of maintenance leading to more efficient operations.

Applications include:

- Liquefied Petroleum Gas (LPG) applications
- For the loading and unloading of pressure tank cars

### 2.1 COMPONENT IDENTIFICATION AND PARTS LISTINGS

ITEM	QTY	DESCRIPTION	A-720		A-721		A-724	
			PART NO.	MATERIAL	PART NO.	MATERIAL	PART NO.	MATERIAL
1	1	HANDWHEEL	720-1-AL	ALUMINUM	720-1-AL	ALUMINUM	720-1-AL	ALUMINUM
2	1	STEM	720-2A-SS	STAINLESS	720-2A-SS	STAINLESS	720-2A-SS	STAINLESS
3	1	GASKET RETAINER ASSY	720-301-CS	STEEL	720-301-CS	STEEL	720-301-SS	STAINLESS
4	1	BODY	720-4-CS	STEEL	721-4B-DI	DUCTILE IRON	720-4-SS	STAINLESS
5	1	SPRING, COIL	720-5-SS	STAINLESS	720-5-SS	STAINLESS	720-5-SS	STAINLESS
7	1	OUTLET FLANGE	720-71-CS	STEEL	720-71-CS	STEEL	720-71-SS	STAINLESS
8	1	PACKING SCREW W/ INSERT	720-8-CS	STEEL	720-8-CS	STEEL	720-8-N60	NITRONIC 60
9A	1	PACKING WASHER TOP	720-93-SS	STAINLESS	720-93-SS	STAINLESS	720-93-SS	STAINLESS
9B	1	SPACER	720-95-SS	STAINLESS	720-95-SS	STAINLESS	720-95-SS	STAINLESS
10	1	WIPER	713-33-PK	PEEK	713-33-PK	PEEK	713-33-PK	PEEK
11	4	PACKING	720-11-TF	TEFLON™	720-11-TF	TEFLON™	720-11-TF	TEFLON™
12	1	STEM SEAL	720-12-BN*	BUNA-N*	720-12-BN*	BUNA-N*	720-12-BN*	BUNA-N*
13	1	"O" RING OUTLET	720-131-BN*	BUNA-N*	720-131-BN*	BUNA-N*	720-131-BN*	BUNA-N*
14A	1	HANDWHEEL NUT	10-15-SS	STAINLESS	10-15-SS	STAINLESS	10-15-SS	STAINLESS
14B	1	WASHER	308-12-CS	STEEL	308-12-CS	STEEL	308-12-CS	STEEL*
15A	4	BOLT	724-15-SS	STAINLESS	724-15-SS	STAINLESS	724-15-SS	STAINLESS
15B	4	LOCKWASHER	724-152-SS	STAINLESS	724-152-SS	STAINLESS	724-152-SS	STAINLESS
16	1	OUTLET PLUG & CHAIN*	720-16-CS	STEEL, PLATED	720-16-CS	STEEL, PLATED	720-16-SS	STAINLESS
18A	1	STEM RETAINER	720-18-SS	STAINLESS	720-18-SS	STAINLESS	720-18-SS	STAINLESS
18B	2	NUT	720-181-SS	STAINLESS	720-181-SS	STAINLESS	720-181-SS	STAINLESS
21	1	PACKING LOCK NUT	720-21-CS-G	STEEL	720-21-CS-G	STEEL	720-21-CS-G	STEEL
22	1	NAMEPLATE	720-22-SS	STAINLESS	720-22-SS	STAINLESS	720-22-SS	STAINLESS

Table 2-1 A-720/A-721/A-724 Component Parts Listing

\*Alternate materials available

**2.1 COMPONENT IDENTIFICATION AND PARTS LISTINGS (CONT.)**

ITEM	QTY	DESCRIPTION	A-721-B	
			PART NO.	MATERIAL
1	1	HANDWHEEL	720-1-AL	ALUMINUM
2	1	STEM	720-2A-SS	STAINLESS
3	1	GASKET RETAINER ASSY	720-3-CS	STEEL*
4	1	BODY	721-42B-DI	DUCTILE IRON
5	1	SPRING, COIL	720-5-SS	STAINLESS STEEL
6	1	RETAINER COVER	720-6-CS	STEEL*
7	1	OUTLET FLANGE	721-71-CS	STEEL
8	1	PACKING SCREW W/ INSERT	720-8-CS	STEEL
9	1	PACKING WASHER TOP	720-93-SS	STAINLESS STEEL
10	1	SEAT SEAL	720-10-TF	TEFLON™*
11	4	PACKING	720-11-TF	TEFLON™
12	1	STEM SEAL	720-12-BN	BUNA-N
13	1	"O" RING OUTLET	721-13-GY	GYLON 3510
14A	1	HANDWHEEL NUT	10-15-SS	STAINLESS STEEL
14B	1	WASHER	308-12-CS	STEEL
15A	4	BOLT	724-15-SS	STAINLESS STEEL
15B	4	LOCKWASHER	724-152-SS	STAINLESS STEEL
16	1	OUTLET PLUG & CHAIN*	720-16-CS	STEEL, PLATED
18A	1	STEM RETAINER	720-18-SS	STAINLESS STEEL
18B	2	NUT	720-181-SS	STAINLESS STEEL
19	1	PIN	720-19-SS	STAINLESS STEEL*
20	1	RETAINER NUT	720-20-CS	STEEL*
21	1	PACKING LOCK NUT	720-21-CS-G	STEEL
22	1	NAMEPLATE	721-22B-SS	STAINLESS STEEL
23	1	SPACER	720-95-SS	STAINLESS STEEL
24	1	WIPER	713-33-PK	PEEK

Table 2-2 A-721-B Component Parts Listing

\*Retainer assembly consisting of Items 3, 6, 10, 19, & 20 will be K-720-301-CS.

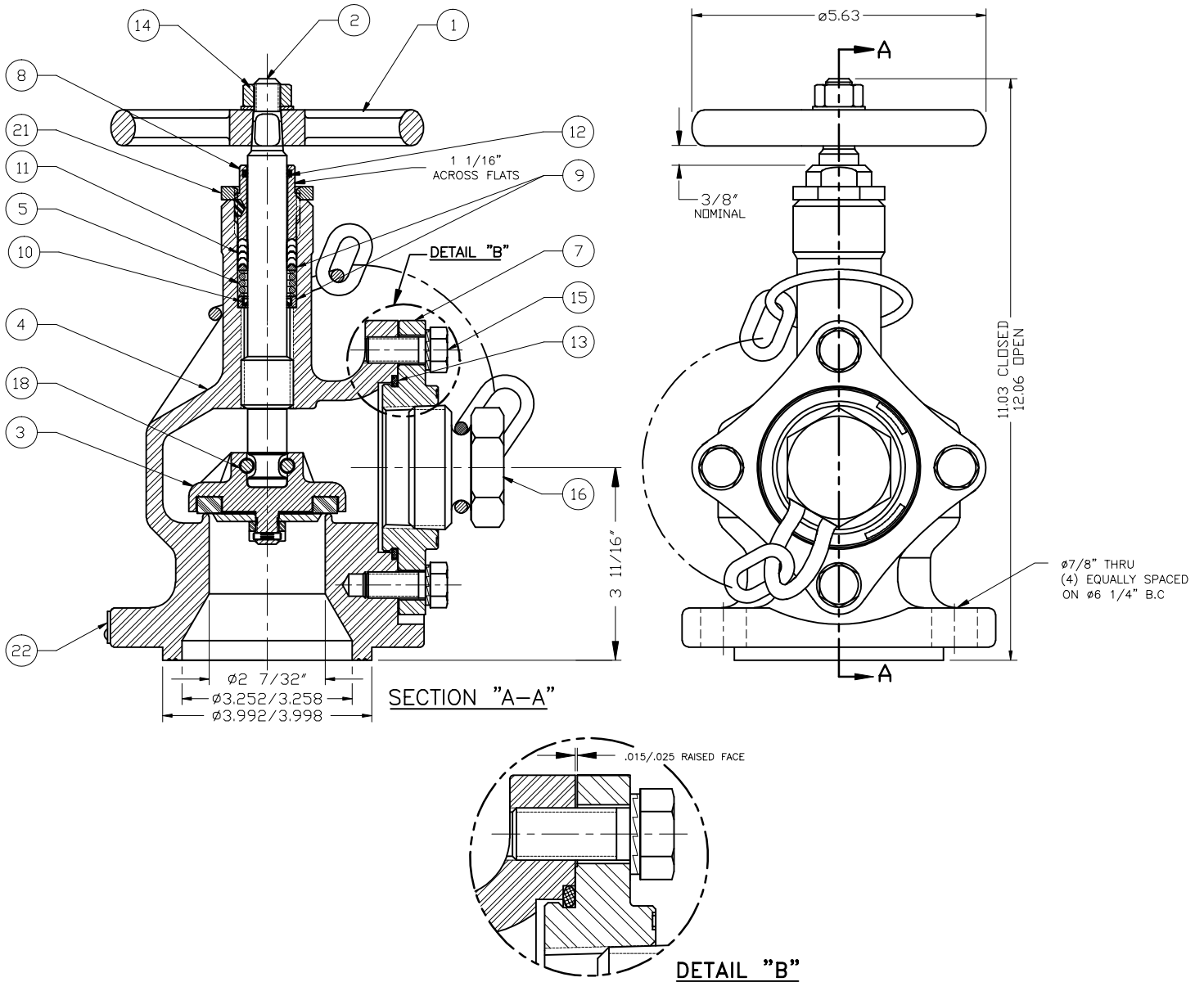

Figure 2-1 A-720/A-721/A-724 Valve Dimensions & Component Identifications

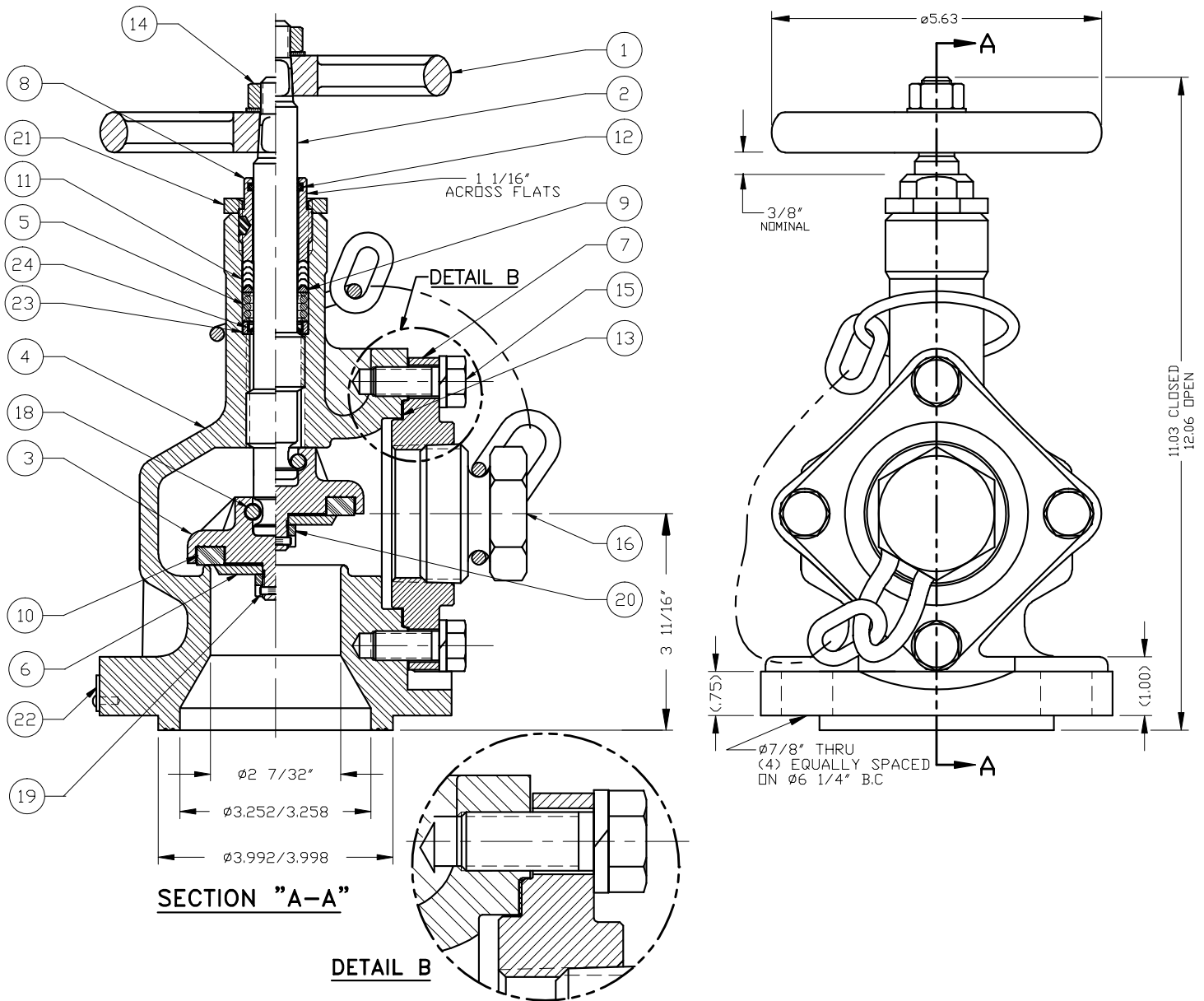

Figure 2-2 A-721-B Valve Dimensions & Component Identifications

## 3 VALVE INSTALLATION

Keep the new Angle Valve in its original shipping container. This will ensure that it remains clean and will protect the gasket face from nicks and other damage.

Prior to installation, ensure that the valve remains clean, and the gasket-sealing surfaces are not damaged.

SAE WRENCH	COMPONENT(S)/DESCRIPTION
7/16" Socket	STEM RETAINER (ITEM 18)
1-1/16"	PACKING SCREW (ITEM 4)
3/4" SAE or 3/4" Crowfoot Wrench	MOUNTING NUTS (NOT SUPPLIED)
<b>OTHER TOOLS, SUPPLIES, AND EQUIPMENT:</b>	
Silicone Grease (or equivalent lubrication)	TO GREASE APPROPRIATE SEALING SURFACES
Lint-Free Cloth	TO CLEAN SEALING SURFACES
Emery Paper (400 grit, cut in 1" strips)	
Wire Brush	TO CLEAN DEBRIS AND SURFACES

Table 3-1 Required tools for valve installation

### 3.1 INSTALLATION AND REQUIRED TOOLS



**NOTICE:** Conform to all regulations and your company's installation instructions. It is not the intention of this pamphlet to conflict with or supersede these requirements.



**CAUTION:** Be sure the car is empty and clean, and that the work area is free of hazardous chemicals that may have been in the car, before removing a valve or installing a new one.

- 3.1.1 Remove the old valve and then insert a soft rubber plug into the tank opening to prevent debris from entering the tank during cleaning of the valve-mounting groove and studs on the man-way cover plate.
- 3.1.2 Wire-brush the stud threads of the cover plate until clean. Properly installed studs will extend 3/4" within the cover plate.
- 3.1.3 Remove the gasket in the groove of the cover plate. Avoid scratching the metal in the bottom of the groove. Discard the used gasket.
- 3.1.4 Examine the sides of the groove to verify that there are no dents or burrs. Since the valve fits tightly in the groove, any peening of the groove edges may make it difficult to properly fit the valve's tongue into the groove.
- 3.1.5 Up to this point, the new valve should have been kept in its original shipping container and a special plastic protector should have been positioned over the tongue on the bottom of the valve.
- 3.1.6 If the valve is reconditioned, or retested, inspect the tongue by running your fingernail around the edge of the tongue to ensure it is free of nicks, gouges and burrs. The tolerance on the tongue is plus or minus 0.003"; therefore, any irregularity in this surface will make it difficult to seat the valve on the cover plate groove.
- 3.1.7 Properly install the new gasket into the groove of the cover plate.
- 3.1.8 Start all four (4) nuts on the studs while the valve is still on the cover plate.
- 3.1.9 Gently lower the valve down onto the cover plate until you feel the tongue goes down into the groove on the cover plate.



- 3.1.10** Wrench-tighten the nuts a little bit at a time, going alternately in a crisscross pattern, from 1 to 3, then 2 to 4. Do not tighten down too much on one side because this will shift the valve at an angle and may make it impossible to get a tight gasket seal.
- 3.1.11** Torque the nuts to a level prescribed by your engineering department. In absence of a recommended company practice, on clean and lubricated threads, it should be safe to torque the mounting nuts to 150 to 200 ft-lb.
- 3.1.12** After the nuts have been tightened down on the cover plate, the valve should be "closed." To seal the valve, it is only necessary to torque the valve handwheel approximately 20 to 30 ft-lb. Under no circumstances should a "cheater" or handle extension be used to close this valve, as over-tightening will damage the valve's Teflon® seat.
- 3.1.13** Inspect the valve for leaks according to your company's procedures for this testing. The primary areas to check are in the side-port area, the packing gland area, the flange connection between the cover plate, and the valve and seat. In order to check the seat for leaks on an installed valve on the tank car, pressure may be applied to the outlet flange with the valve in the "closed" position. Look for any pressure decay. Keep in mind that some compensation would need to be made for pressure changes as temperature changes. This is recommended in the event that there is no procedure in place from your company to test the valve's seat when installed on a tank car. When closing the valve, hand-tighten. If it does not seal, remove the valve for repair per Maintenance Instructions in Section 8.0.

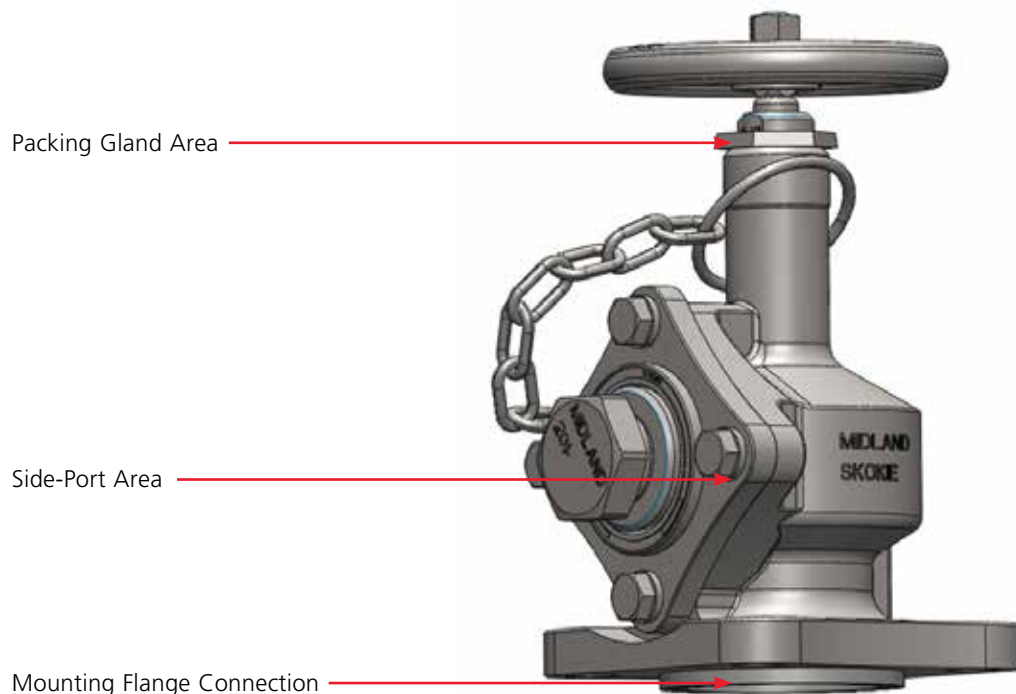

Figure 3-1 Inspect Side-Port Area and Seat



**NOTICE:** If the valve is painted, ensure that the gold-colored locknut is masked before painting.

## 4 OPERATING PROCEDURE

### 4.1 OPENING THE VALVE



**NOTICE:** Operation of the valve must conform with all applicable CTC, AAR, DOT specifications (Parts 173.31, 174.67, etc.), other governmental bodies, and the operating instructions of your company.

- 4.1.1** Wrench-tighten the nuts a little bit at a time, going alternately in a crisscross pattern, from 1 to 3, then 2 to 4. Do not tighten down too much on one side because this will shift the valve at an angle and may make it impossible to get a tight gasket seal.



**CAUTION:** Do not use an extension or cheater on the valve handle. If it does not move freely, report this to the tank car supervisor. The tank may be pressurized, contain solidified product, or the valve may be jammed.

- 4.1.2** Examine the pipe plug. Be sure its threads are clean, free from corrosion, not worn or crossed. Also, examine the threads on the side port to see that they are in good operating condition.
- 4.1.3** This valve has an adjustable packing gland. Routine maintenance consists of periodic inspection and adjustment of the packing nut (item 8) to compensate for the stem seal wear. This may be done by loosening the gold locknut (item 21) and tighten the packing screw to 65 ft-lb using a 1-1/16" wrench. More frequent observations are recommended under extreme operating conditions. Unnecessary overtightening will cause excessive frictional drag on the valve stem. Then torque the locknut (Item 21) to 65 ft-lb in order to keep the packing screw from unwinding during operations.

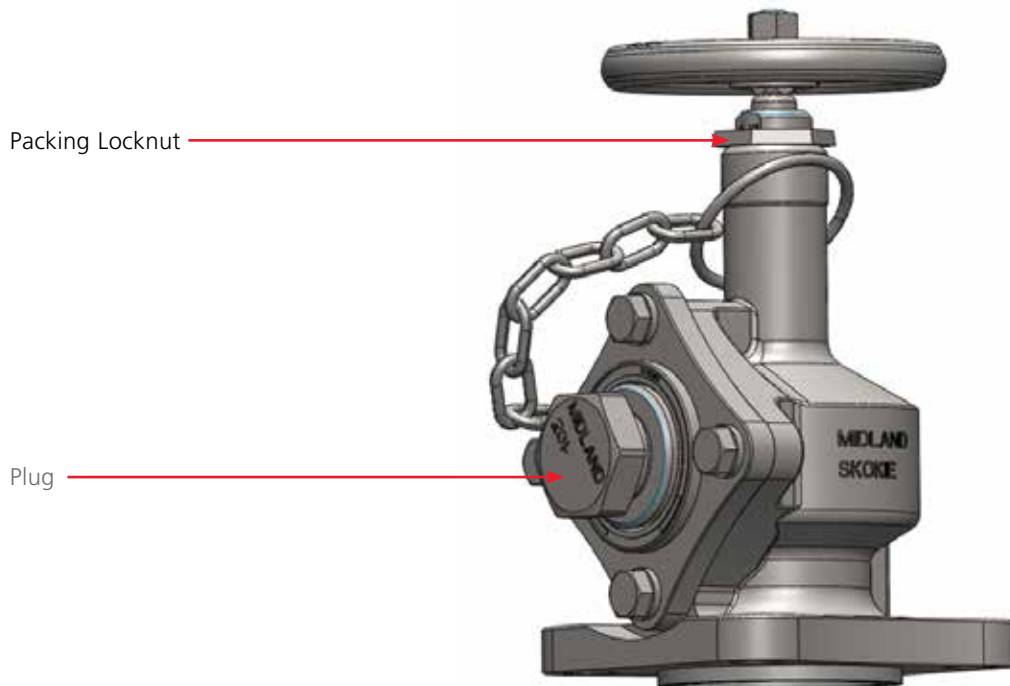

Figure 4-1 Plug and Packing Locknut

## 5 VALVE QUALIFICATION



### NOTICE

**NOTICE:** Whenever angle valves are retested, it is recommended that new O-rings be installed. The Teflon® seat seal and packing should be replaced, if there is any question about their serviceability. All replacement parts must be obtained from Midland Manufacturing Corp. No re-machining of any parts is permitted. By not observing these prohibitions the purchaser assumes full responsibility and liability for the proper functioning of the valves.

- 5.1.1 HANDWHEEL.** This part is designed to fail when the stem is over-torqued. If a spoke is cracked, or broken off, the handwheel must be replaced.



Figure 5.1.1 Handwheel

- 5.1.2 STEM.** Roll the stem on a flat and true surface. It will be apparent if the stem is bowed. If you attempt to straighten it, do not grip or deflect it on the ground surface in the packing seal area, nor in the acme thread, where deformation of the metal would make it difficult to move it freely. All nicks, burrs, pits, scratches, etc., must be eliminated, or discard the stem. Inspect for cracks in the thread root area. If any are detected, discard the stem. Screw the stem through the acme thread of the body with packing screw in place to make sure it moves freely without any binding.



Figure 5.1.2 Valve Stem

## Installation, Operation & Maintenance Manual

---

- 5.1.3 BODY.** Inspect the part for corrosive degradation, particularly in the seat, threads, packing sealing and the side port areas. Clean off these areas to be sure they are free of corrosion, contamination, pits, scratches, etc., that could form leak paths. The threads are 1/2"-13 for the valve on the side flange. If any of the threads are stripped or corroded, discard the body.

Figure 5.1.3 Valve Body

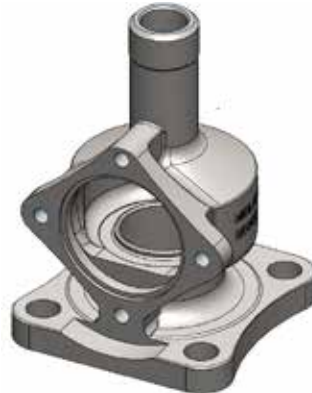

- 5.1.4 RETAINER ASSEMBLY.** If the Teflon® seat is deformed by the body insert to a depth of 1/16-inch, or if it has embedded debris, discard it. Replace it with a new seat seal from the factory. This part is custom made for use on Midland valves only and must be purchased from Midland.

Figure 5.1.4 Gasket Retainer



- 5.1.5 OUTLET FLANGE.** The surfaces where the O-ring fits, and the flat gasket surfaces must be free of nicks, scratches, and pits. Similarly, the 2" or 3" NPT must be in good condition. It can be cleaned with the standard NPT hand tap. However, a thread gage should be used to be sure the thread is not oversized. The standard hand-tight engagement is 0.436 inches for the thread. The acceptable tolerance is plus or minus one thread. If this tolerance is exceeded, a new part must be obtained.

Figure 5.1.5 Outlet Flange



- 5.1.6 PACKING SCREW.** The thread is 1¼"-12 on the valve. It must be clean and sharp without nicks, scratches, pits, and other defects that would strip or gall the thread when screwed into the body.



Figure 5.1.6 Packing Screw

- 5.1.7 BOTTOM SPACER WITH WIPER:** The outer surfaces of the spacer surfaces must be free of nicks, scratches, and pits. The internal wiper is clean without nicks and other defects. This part is custom made for use on Midland valves only and must be purchased from Midland.



Figure 5.1.7 Bottom Spacer with Wiper

- 5.1.8** The remainder of the parts are O-rings, packing, gaskets, bolts, several types of nuts, lock washers, pins, etc. These are inexpensive parts and to ensure that the right sizes, hardness, strengths, materials, and correctly dimensioned parts are used, these replacement parts should be obtained from the factory.

## Installation, Operation & Maintenance Manual

---

### 5.1.9 Special Inspection Considerations

---



**NOTICE**

**NOTICE:** Repair work is limited to cleaning and polishing.

---



**WARNING**

**WARNING: Machining Not Allowed.** Without consent from the valve manufacturer or car owner, machining, grinding, welding or other alterations to the valve seat or stem seat is not allowed per AAR M1002, Paragraph A3.11.1 of the Tank-Car Specifications.

---



**NOTICE**

**NOTICE:** Please refer to paragraph A3.11.2 of the Tank-Car Specifications and consult Appendix E for dimensions and applicable tolerances.

---

- 5.1.9.1** Previous procedures may not cover all conditions encountered in the field. Therefore, it is the responsibility of the repair agency to obtain approval from Midland for inspection, evaluation, repair and maintenance procedures not covered herein.
- 5.1.9.2** Facilities performing recommended dye-penetration and magnetic-particle testing must carry out such testing according to a qualified procedure conducted by certified trained personnel.
- 5.1.9.3** Evaluation of critical component metal surfaces of the valves after cleaning, inspection and specialized testing performed by agencies other than the repair facility are the responsibility of the repair facility
- 5.1.9.4** Where numerical tolerances cannot be provided, the disposition of the internal integrity and surface quality of parts is under the jurisdiction of the repair facility and dependent on its experience and judgment.

## 6 VALVE DISASSEMBLY

- 6.1.1** Before valve disassembly, open and close the hand wheel to run the stem (item 2) up and down to ensure that the stem is neither bent nor binding in the threaded part of the body (item 4). Bent stems must be straightened to proceed with the disassembly.
- 6.1.2** Place the valve in a vise, gripping it on the flat faces of the 6" square flange with the stem horizontal and the side-port on the top.

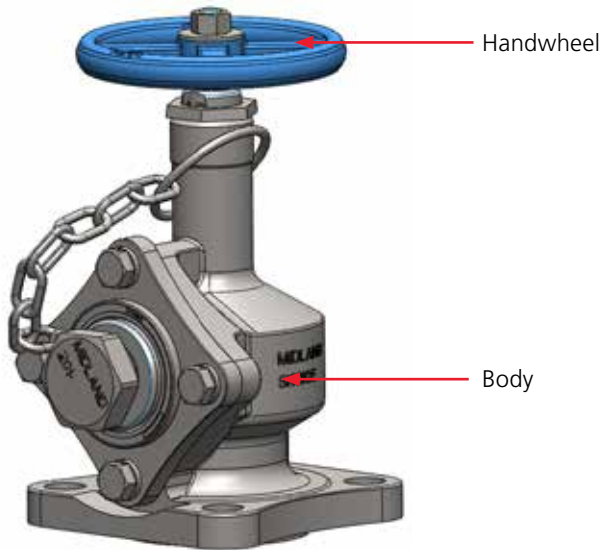

Figure 6-1 Turn handwheel

- 6.1.3** Remove the pipe plug (item 16).



Figure 6-2 Pipe plug removed

**6.1.4** Take off the four (4) side flange bolts and lock washers (items 15A and 15B, respectively).

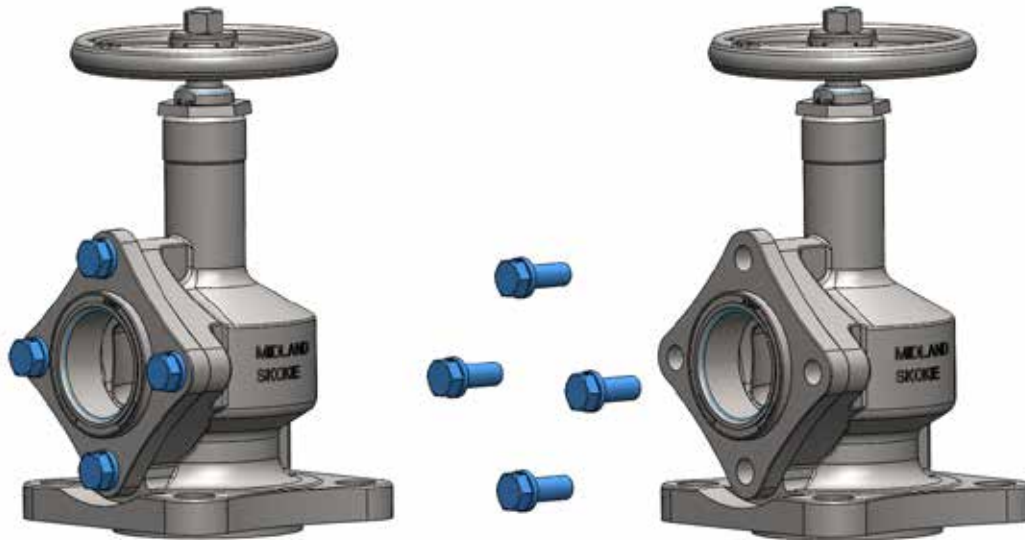

Figure 6-3 Remove flange bolts and washers

**6.1.5** Carefully remove side outlet flange (item 7). It may be necessary to insert two (2) screwdrivers (180° degrees apart) between the flange and the valve body to pry it out. Care to be taken so not to damage the mating surfaces between the body and flange

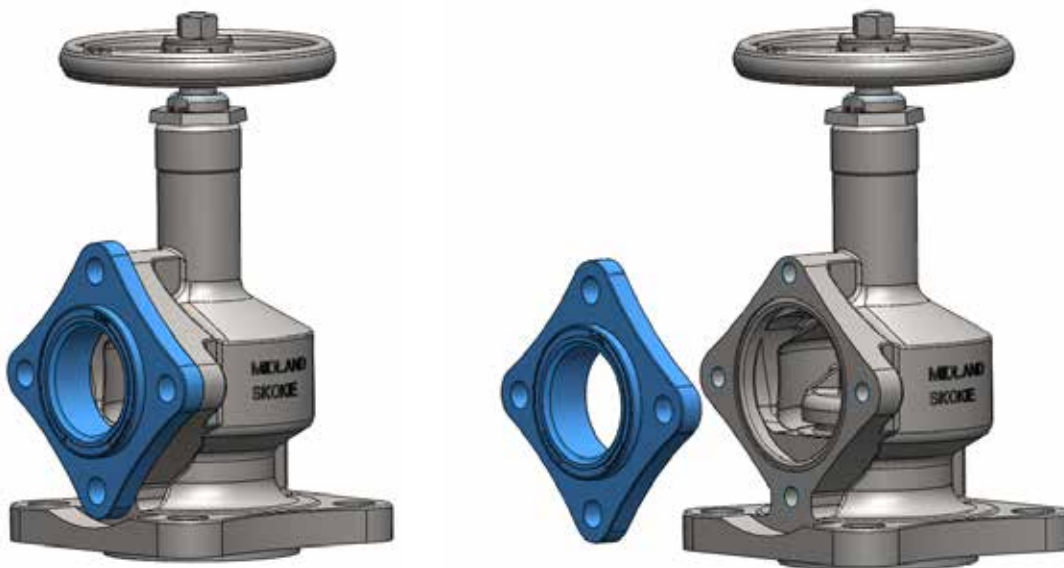

Figure 6-4 Remove outlet flange



- 6.1.6** Raise the hand wheel slightly to lift the gasket retainer (item 3). Rotate it so that the two (2) nuts (item 18) are facing out the side flange opening. Tighten down on the handwheel to keep the gasket retainer from rotating out of position.

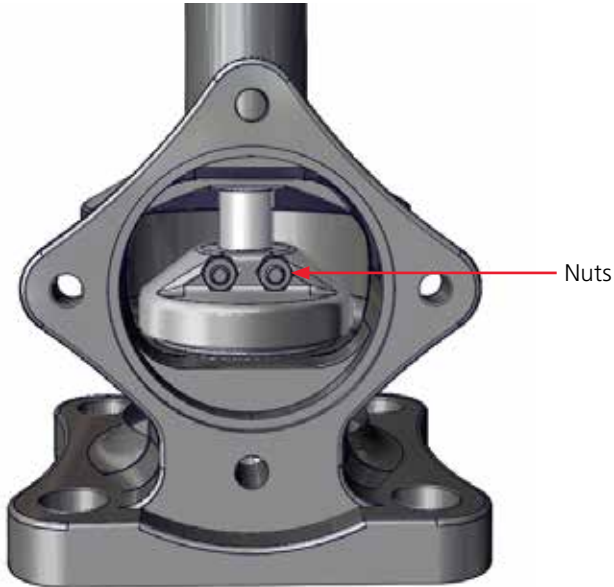

Figure 6-5 Rotate handwheel to view nuts

- 6.1.7** Take a 7/16" socket wrench and unscrew the nuts. Using a block of steel that spans both sides of the U-bolt (about 1" wide), tap the block to loosen the U-bolt and push it out about 1/4". Open the handwheel again and rotate the gasket retainer 180°, then tighten down on the handwheel to put tension on the gasket retainer. Then use a tool to pull the U-bolt out.

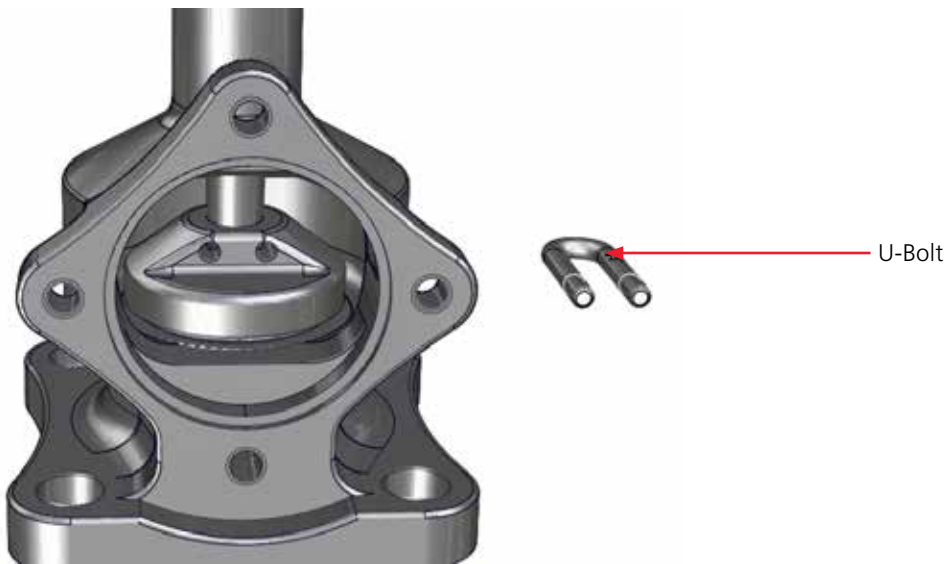

Figure 6-6 Remove nuts and U-Bolt

- 6.1.8** Raise the stem (item 2) up in the body as far as it will go. It now is possible to take the gasket retainer out of the valve. Needle-nose pliers may be helpful in gripping the gasket retainer to extract it through the side port opening.

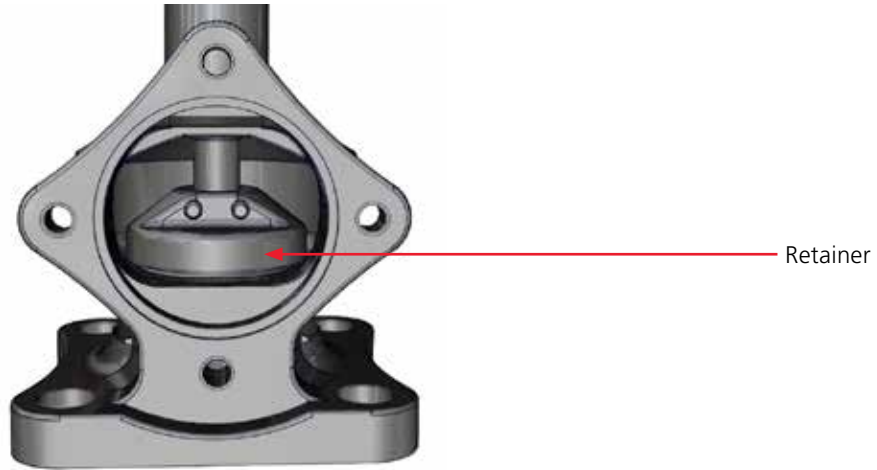

Figure 6-7 Remove retainer

- 6.1.9** Take a 7/16" socket wrench and unscrew the nuts. Using a block of steel that spans both sides of the U-bolt (about 1" wide), tap the block to loosen the U-bolt and push it out about 1/4". Open the handwheel again and rotate the gasket retainer 180°, then tighten down on the handwheel to put tension on the gasket retainer. Then use a tool to pull the U-bolt out.
- 6.1.10** The packing gland (item 11) can now be pulled out of the body with the standard packing tools.

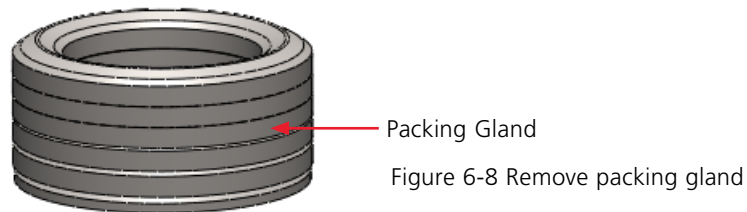

Figure 6-8 Remove packing gland

- 6.1.11** Loosen or remove the packing locknut (see step number 6.1.9). Turn the handwheel to lower or raise the stem as far as it will go. Then take off the handwheel nut, washer, and handwheel. Gripping on the flats of the stem square with an open-end wrench or vise grips continue to unwind the stem down. If the stem cannot be taken out the last few threads by hand, it may be necessary to lightly grip the bottom of the stem with vise grips to disengage it from the body.

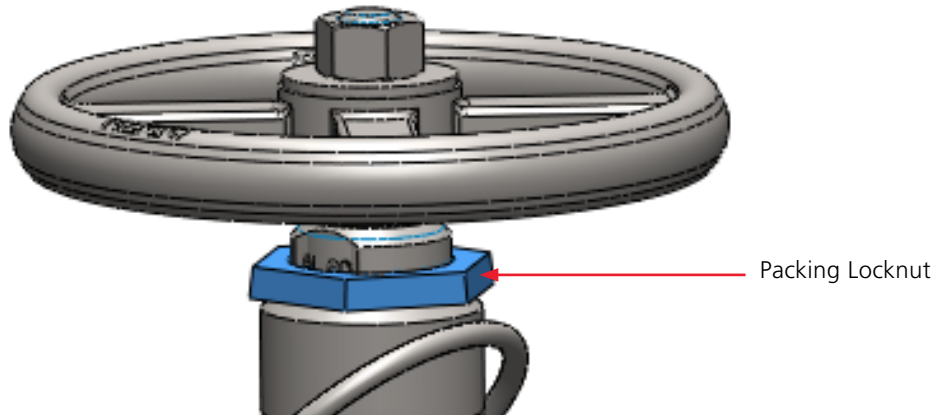

Figure 6-9 Loosen locknut and remove packing

- 6.1.12** Remove the packing top washer, coil spring and bottom space through the top of the valve.

## 7 VALVE REASSEMBLY AND TESTING PROCEDURES

### 7.1 CLEANING



**NOTICE**

**NOTICE:** Do not use solvents or grease lubricants that are incompatible with the products in the tank. For example, a petroleum-based grease may cause a chemical reaction when it comes in contact with chlorine. Contact your supervising engineer for suitable cleaning and lubricating material recommendations. O-rings and metallic parts that fit together should be lightly greased.

### 7.2 REASSEMBLY PROCEDURE



Figure 7-1 Reassembly Steps 7.2.1 through 7.2.7

- 7.2.1** Place the lower spacer with wiper (item 10) in the body (item 4) with the wiper side up; see Figure 7-1.
- 7.2.2** Put the spring (item 5) in the body; see Figure 7-1.
- 7.2.3** Install the upper (curved) packing washer (item 9) in the body, with the convex side up; see Figure 7-1.
- 7.2.4** The 2" valve use four (x4) Teflon™ V-rings (item 11) in the body; see Figure 7-1.
- 7.2.5** Insert the stem seal (item 12) with Teflon™ insert in the packing screw (item 8); see Figure 7-1.
- 7.2.6** Thread the packing screw into the body by pushing down against the spring and turning clockwise to engage the thread. Wrench tighten a couple of turns.
- 7.2.7** Screw down the packing locknut (item 21) a couple of threads on the packing screw); see Figure 7-1.

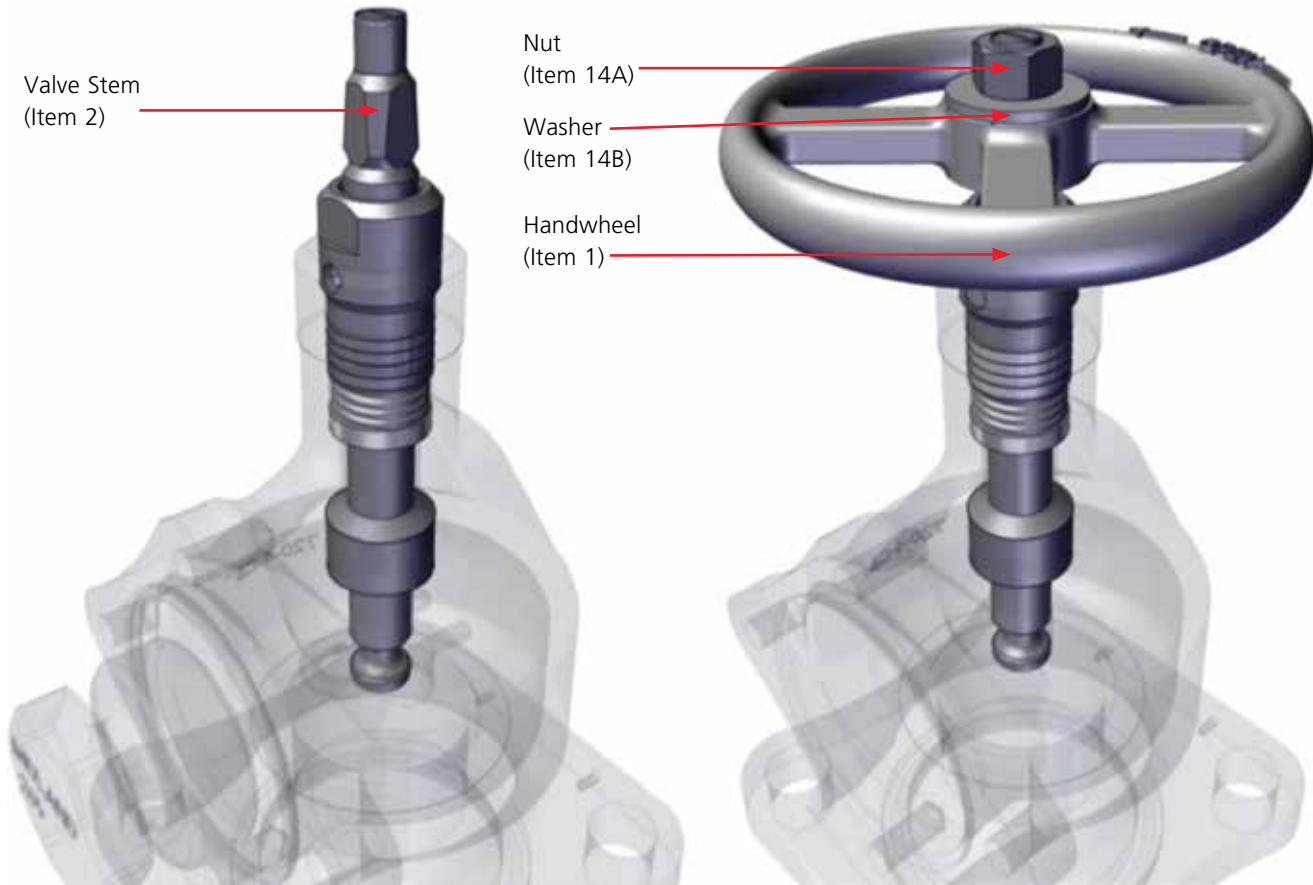

Figure 7-2 Reassembly steps 7.2.8 through 7.2.10

- 7.2.8** From the bottom side of the body, insert the handwheel end of the stem (item 2). Screw the stem up until the handwheel flats clear the top of the packing screw; see Figure 7-2.
- 7.2.9** Put on the handwheel (item 1), and then the handwheel lock washer (item 14). By hand, screw the handwheel nut (item 14) onto the stem as far as it will go; see Figure 7-2.
- 7.2.10** Turn the handwheel counter clockwise to move the stem up into the neck of the body. It should move easily. After several turns, stop when the stem thread come into contact with the lower packing washer (item 9); see Figure 7-2.

7.2.11 Retainer Reassembly



Figure 7-3 Reassembly steps 7.2.11.1 through 7.2.11.3

**7.2.11.1** Place gasket retainer (item 2) into a vice as shown.

**7.2.11.2** Place seat seal (item 10) in the gasket retainer (item 2), place the seal washer on top of the seat seal as shown

**7.2.11.3** Make sure seal washer is flat with the seat seal



Figure 7-4 Reassembly steps 7.2.11.4 through 7.2.11.5

**7.2.11.4** Hand tighten the retainer nut (item 20) and use calibrated torque wrench to tighten the retainer nut (item 20) to 35 ft-lbs

**7.2.11.5** If the slot matches with the pin hole, no need to tighten further. If not, tighten to next slot



**CAUTION:** Make sure the torque on retainer nut does not exceed 50 ft-lbs.



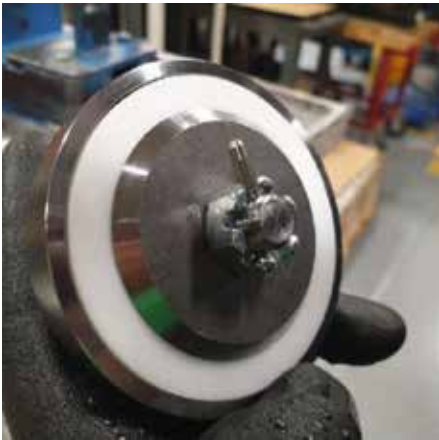

Figure 7-5 Reassembly steps 7.2.11.6 through 7.2.11.7

**7.2.11.6** Place the pin (item 19) into the hole as shown, tap the pin into place.

**7.2.11.7** Place the retainer assembly into the fixture as shown



Figure 7-6 Reassembly step 7.2.11.8

**7.2.11.8** Use the handle of press fixture to insert the pin as shown in Figure 7-6

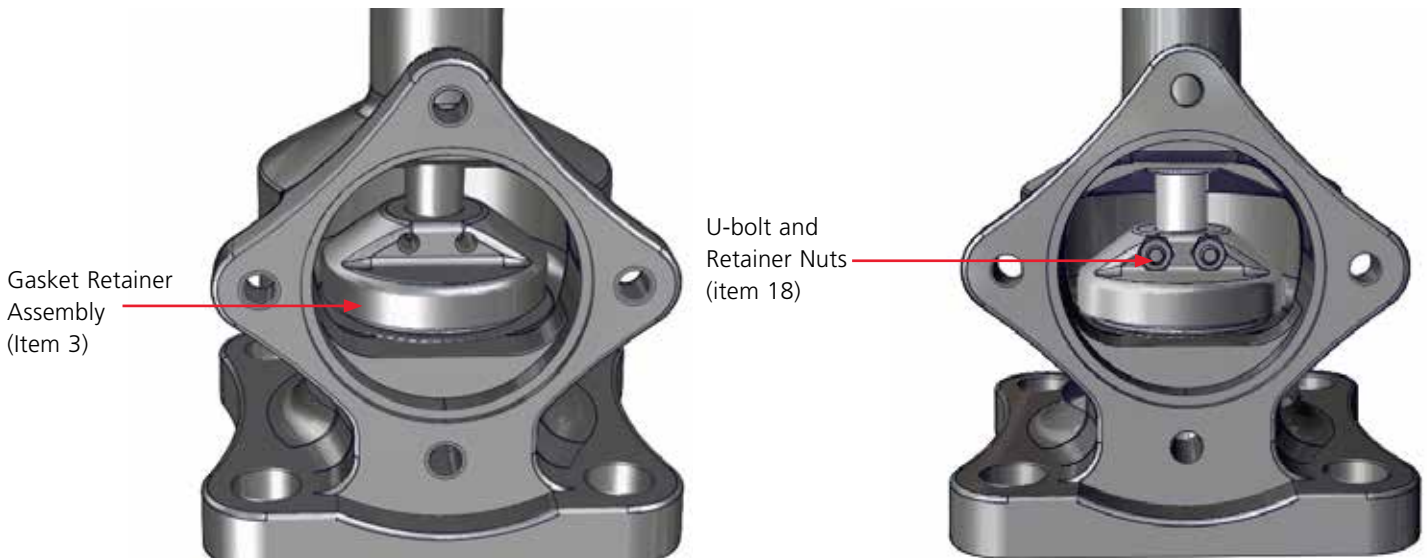

Figure 7-7 Reassembly steps 7.2.12 through 7.2.15

- 7.2.12** Position the gasket retainer assembly into the valve body through the side port so that the seat seal (item 10) is resting on the body seat; see Figure 7-7.
- 7.2.13** Turn the valve handwheel clockwise to lower the stem into the recess in the gasket retainer (item 3). Orient the retainer so the two holes for the retainer are accessible through the side port; see Figure 7-7.
- 7.2.14** Insert the stem retainer U-bolt through the holes in the retainer and the groove of the stem to couple these parts. Lightly tap in the U-bolt so the threaded ends go as far through the gasket retainer holes as the base of the U-bolt will permit; see Figure 7-7.
- 7.2.15** Open the valve about ¼-turn and rotate the gasket retainer 180°, and reclose the valve. Install the two retainer nuts (item 18) and tighten them down securely with a socket wrench. It may be necessary to keep the U-bolt forward with one finger on one leg while installing a nut on the other leg; see Figure 7-7.

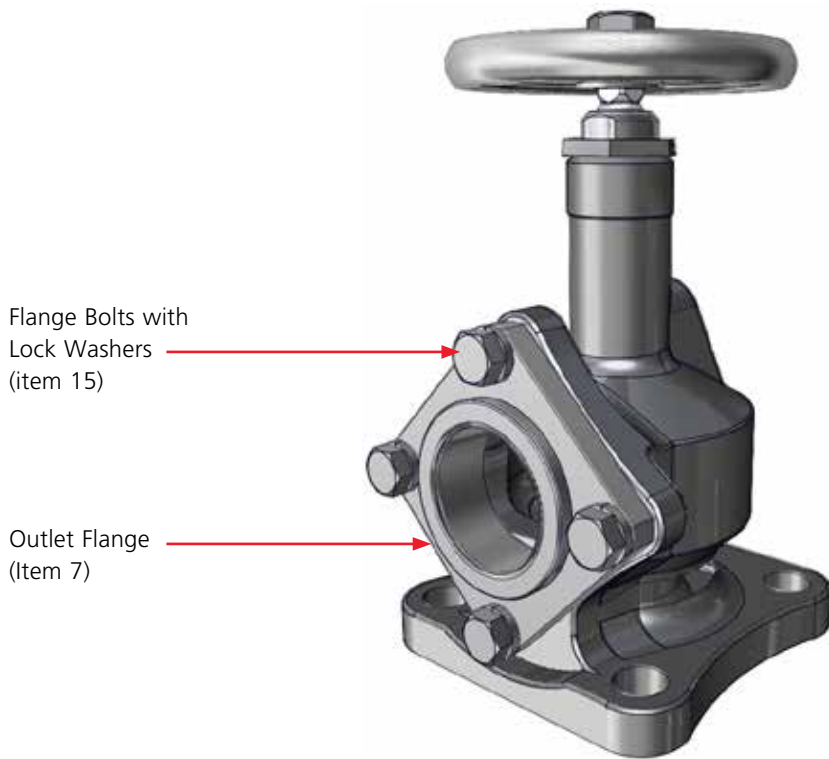

Figure 7-8 Reassembly steps 7.2.16 through 7.2.21

- 7.2.16** Install the outlet O-ring (item 13) if on A-720/721/724 onto the outlet flange (item 7). Install the outlet gasket (item 13) if on A-721-B onto the outlet flange (item 7). Push this assembly into the side port of the body; see Figure 7-8.
- 7.2.17** Screw in the flange bolts with lock washers (item 15) hand tighten, and then wrench-tighten the bolts using the alternate tightening pattern. Do not exceed 45 ft-lb. Check for uniform spacing between the two flange faces. Correct by loosening and retightening; see Figure 7-8.
- 7.2.18** Tighten packing screw (item 8). Tighten to 65 ft-lb for all valve models.
- 7.2.19** Tighten packing locknut (item 21) to 65 ft-lb for all valve models.
- 7.2.20** While holding the handwheel in place, wrench-tighten the handwheel nut.
- 7.2.21** The valve is now ready for testing



If your company has an approved test procedure, follow it. If it does not, these procedures provide essential guidelines in regard to pressure testing.

**CAUTION**

**CAUTION: Safety Protection.** Wear appropriate safety glasses or face-shield and protective clothing when conducting this procedure. Valve testing involves high-velocity air and water flow that can cause injury.

**7.3 TESTING PROCEDURE**

- 7.3.1** Locate the valve onto a test fixture.
- 7.3.2** Secure the valve to the test fixture with at least 1/2" gap between the gasket retainer and the seat.
- 7.3.3** After the valve is secured to the test fixture, close the valve. It should only be necessary to torque the handwheel about 20 to 30 ft-lb to achieve a bubble-tight seal against a 600 psig air supply to the valve.
- 7.3.4** The 600 psig value stated in this manual, and on the valve nameplate, indicates the capability of the Midland A-72X Angle Valve Family, and the pressure at which the valve is tested at the factory. Valves must be tested at a pressure appropriate for the application. Typical practice in the valve industry (using ASME B16.34 as a guide) is to test the body at 1.5 times the maximum working pressure (with water or air) and test the seat at 1.1 times maximum working pressure (with air). This applies to the Midland A-72X angle valve with the caveat that either test pressure should not exceed 700 psig. Midland's recommendation is to test the A-72X Angle Valve at the above conditions and record those values on a test report, if applicable, and on a tag affixed to the valve which also indicates the organization performing the test.

**NOTICE**

**NOTICE:** If the body and seat are tested at 600 psig, the test pressures on the supplemental tag are not required.

- 7.3.5** There are several acceptable methods of checking for a seat leak, but one simple way is to put pieces of wide masking tape across the side port. Put a small hole in the center of the tape and cover the hole with a little soap suds solution. Any leak will then result in a bubble forming at the hole.
- 7.3.6** After the seat has been satisfactorily tested for leakage, thread the pipe plug into the side port. Open the handwheel to pressurize the body cavity and inspect for leaks around the pipe plug and the outlet flange with soap suds.
- 7.3.7** Then with soap suds, check the packing gland area. Wrench the packing screw down slowly until the 65 ft-lb of torque is achieved then lower the locknut on the packing screw. Tighten the locknut to torque of 65 ft-lb to complete the assembly.

**7.4 POST-TEST PROCEDURES**

- 7.4.1** After satisfactorily testing the valve, close-off the supply pressure to the test stand, relieve the pressure and un-mount from test fixture.
- 7.4.2** Open valve to drain any water that may have accumulated, then wipe or blow away, with an air hose, any soap suds and water used during testing.
- 7.4.3** Open the handwheel a turn or two to be sure that the gasket retainer is not in contact with the body seat.
- 7.4.4** Put the plastic tongue protector over the body insert tongue to prevent damage to it.
- 7.4.5** Put an appropriate preservative, such as WD-40 or equivalent, or paint on the exterior of the valve, be sure to mask off the nameplate so it will remain readable afterwards. If the valve is painted, ensure the gold color locking nut is masked before painting.
- 7.4.6** Fill in the test date information on the tag located on the valve. Store the valve in a dry place until ready to use.

## 8 MAINTENANCE

---



### NOTICE

**NOTICE:** It is essential to establish a periodic retesting and preventative maintenance program with angle valves. The DOT and AAR have set forth a retesting interval that should be considered the maximum length of time between tests. If your company's experience indicates that a short interval is advisable, a program with more frequent retesting should be implemented.

**NOTICE:** New O-rings should be installed when a valve is retested.

---

### 8.1 PRIOR TO MAINTENANCE TASKS PERFORMED

#### 8.1.1 Required Tools

**8.1.1.1** Obtain the required tools and supplies before attempting maintenance procedures. Table 1-3 outlines some suggested tools that will be needed.

### 8.2 LEAK REPAIR ON A MOUNTED VALVE

**8.2.1** Inspect the valve for leaks according to your company's procedures for this testing. To repair packing gland area leak, loosen the packing lock nut, then wrench the packing screw down slowly until the leak stops. Then turn another 1/4-turn and lower the locknut on the packing screw.

---



### CAUTION

**CAUTION:** The repair procedure for a mounted valve is intended only as a temporary repair. Once a product is unloaded and pressure is relieved. The valve should be removed for further repairs and full requalification.

---



### NOTICE

**NOTICE:** It is the responsibility of the car owner to develop a maintenance and qualification program that ensures the valve and fittings meet the performance specifications. Midland's guidelines are meant to assist in the development of the maintenance and qualification program.

**NOTICE:** Midland identifies the replacement of the face plate or outlet flange, on a Midland angle valve, not to be a part of the Resealing, Rebuild or Remanufacturing of the valve or fitting. The face plate or outlet flange may be changed as a regular part of maintenance, without the removal from the railcar. All proper assembly techniques, torque specification as well as leak testing are required to be performed to ensure the proper performance requirements are met.

---



7733 Gross Point Road ⇒ Skokie, IL 60077  
Tel: (847) 677-0333 ⇒ Fax: (847) 677 0138

[www.midlandmfg.com](http://www.midlandmfg.com)

**DEFINING | WHAT'S NEXT**