

A-174-P and A-177-P 3" Excess Flow Valve

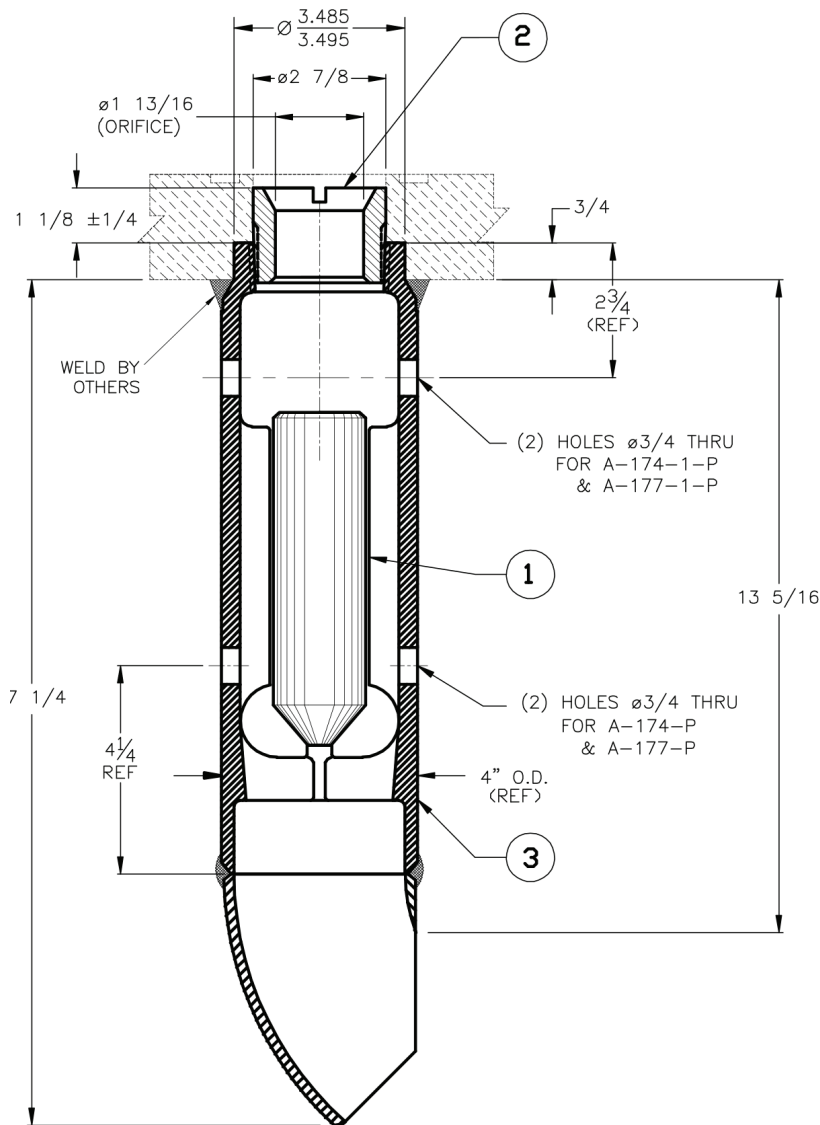

ITEM NO.	QTY.	PART NAME	A-174-P		A-177-P	
			MATERIAL	PART NO.	MATERIAL	PART NO.
1	1	FLOAT	STEEL	164-1-CS	STAINLESS	167-1-SS
2	1	PLUG ⁽¹⁾	STEEL	164-2-CS	STAINLESS ⁽²⁾	167-2-SS
3	1	BODY ASM	STEEL	174-32-CS	STAINLESS	177-32-SS

ITEM NO.	QTY.	PART NAME	A-174-1-P		A-177-1-P	
			MATERIAL	PART NO.	MATERIAL	PART NO.
1	1	FLOAT	STEEL	164-1-CS	STAINLESS	167-1-SS
2	1	PLUG ⁽¹⁾	STEEL	164-2-CS	STAINLESS ⁽²⁾	167-2-SS
3	1	BODY ASM	STEEL	174-33-CS	STAINLESS	177-33-SS

NOTES:

1. USE WRENCH T-312-CS TO INSTALL OR REMOVE PLUG.
2. FOR NITRONIC 60 PLUG, ADD SUFFIX -N60 TO A-177-P & 177-1-P (i.e A-177-P-N60 & A-177-1-P-N60).

AAR E122001
FOR VAPOR LINE

June 30, 2017