

## 888L Loading Arm Lockdown Assembly

H32606PA  
 July 2012

To further enhance the safety of your loading system, OPW Engineered Systems offers the 888L Loading Arm Lockdown Assembly. This device provides additional control of the loading arm during loading operations, while enabling the system to maintain a full range of motion. Several mounting options are available, allowing the operator to incorporate the 888L Loading Arm Lockdown Assembly in a variety of applications, ranging from the transfer of very viscous liquids to those that involve extremely high loads.



888L Loading Arm Lockdown Assembly

### SELECTION GUIDE

**888L - 3 8 RH - 69**

**Product**

888L = OPW Loading Arm Lockdown Assembly

**Size**

3 = 3" Piping  
 4 = 4" Piping

**Swivel Series**

8 = 8000 Series

**Feed**

RH = Right-handed arm  
 LH = Left-handed arm

69 = Cable Length (69")

CR = Cable Release  
 MR = Manual Release

### INSTALLING YOUR LOCKDOWN DEVICE

#### Step 1: Install Support Plate

Mount side-support plate to swivel sealing flange using supplied bolts and washers. The side-support plate must be mounted with the "R" stamped surface of the plate facing out as shown for right-hand loading arms and the "L" stamped surface facing out for left-hand loading arms.

Note: Measure the angle of the side support plate:  
 3" DSF: 72° 4" DSF: 77°

Tighten the bolts using the proper torque:  
 3" DSF: 28 Foot-Pounds  
 4" DSF: 75 Foot-Pounds

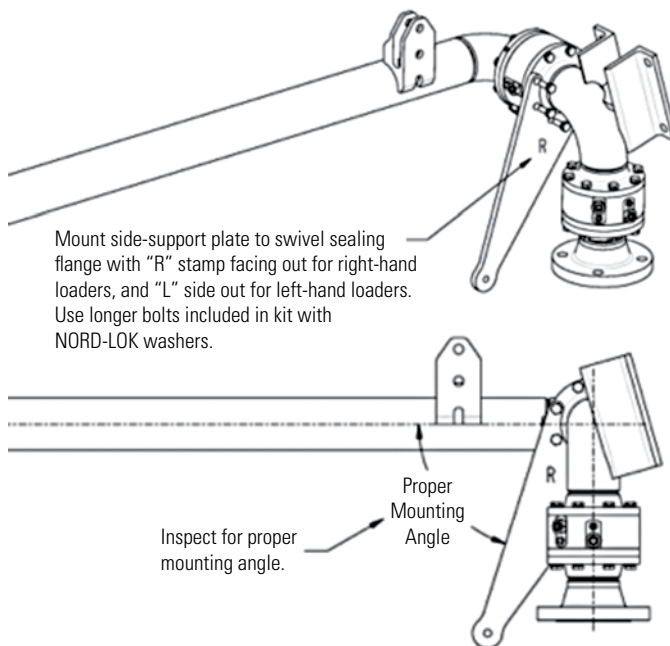

Mount side-support plate to swivel sealing flange with "R" stamp facing out for right-hand loaders, and "L" side out for left-hand loaders. Use longer bolts included in kit with NORD-LOK washers.

Inspect for proper mounting angle.

## INSTALLING YOUR LOCKDOWN DEVICE CONTINUED

### Step 2: Mount Pipe Bracket

Mount the pipe-collar bracket at the following distance from the swivel centerline: 3" & 4" DSF loading arms: 41.12"  
Tighten the pipe-collar bolts using the proper torque: 185 foot-pounds.

Note: Measure the angle of the pipe-collar bracket: 3" DSF: 26° 4" DSF: 23°. When properly mounted, the outside surface of the tubing portion of the bracket should be in the vertical plane.

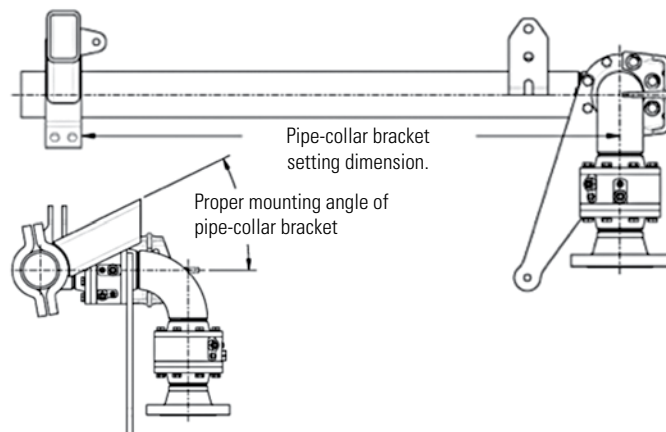

### Step 3: Install Brake Release

Install the brake-release handle bracket assembly to the loading arm as close to the outboard swivel as possible. Tighten the pipe-collar bolts to the proper torque: 105 foot-pounds. The brake release should be located in the middle of the handle with the "nose" end of the brake release facing toward the torsion-spring swivel.

Locate brake-release handle bracket as close to the outboard swivel as possible.

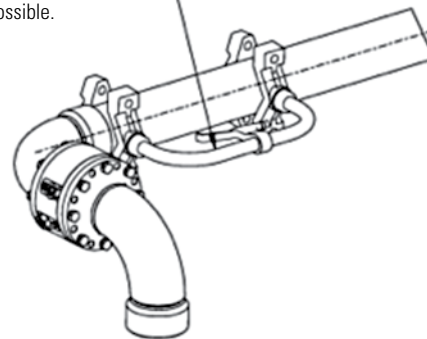

### Step 4: Install Lockdown Tube

Slide one of the bumper stops over the end of the inner tubing weldment assembly. Apply heavy grease to the slotted surface of the inner tube.

Insert inner tubing weldment assembly through rocker assembly with slotted holes facing the locking mechanism of the brake release, as shown. It will be necessary to retract the locking mechanism before inserting the inner tubing weldment through the rocker assembly.

Assemble other end of inner tubing assembly to side-support plate, using shoulder bolt (short), flat washer, lock washer and hex nut.

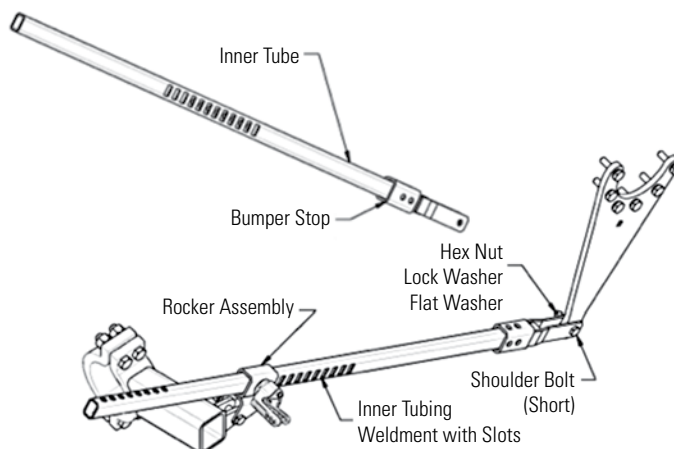

## INSTALLING YOUR LOCKDOWN DEVICE CONTINUED

### Step 5: Install Brake Cable

Loosen the locking nut on the break lever and unthread the nose of the brake release to its full extension. Insert the round plug end of the cable into the brake-release lever and through the nose end of the lever. Cut the cable housing to the proper length. Insert the brake cable through a housing ferrule and through the lubricated cable housing.

Insert a ferrule on the end of the cable housing and feed the cable through the top holes of the rocker assembly and remote control lever. Assemble the spring and cable holder over the brake-release cable. Using pliers, pull all of the slack out of the brake cable and housing. While compressing the spring and keeping the cable tight, tighten the screw in the cable holder to lock the brake cable in place.

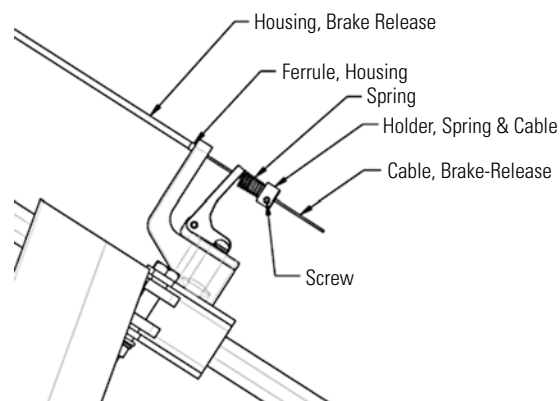

Slide the second bumper stop over the end of the inner-tube assembly. Both bumper stops can now be attached to the inner tube with the bolts and lock washers. The bumper stops can be positioned at various locations on the inner tube to limit the upward and downward travel of the loading arm.

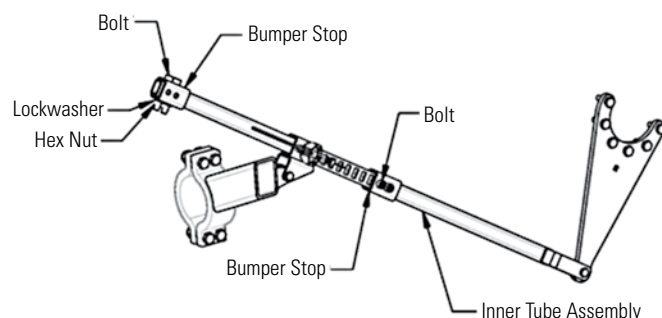

**Test Installation-** Inspect the operation of the lock-down unit by squeezing the brake-release lever to raise the loading arm. Release the brake lever and lower the loading arm. The arm should lower without retracting the brake lever. You should hear a "ratcheting" sound as the locking mechanism slides past the slotted holes of the inner tube. Try to raise the arm with the locking mechanism engaged in a slot of the inner tube. The loading arm should not be able to be raised without retracting the brake release. The loading arm should lock in approximately the horizontal position, and in 5-degree increments below horizontal down to a maximum of -25 degrees below horizontal, depending on which slot the locking mechanism is engaged in.

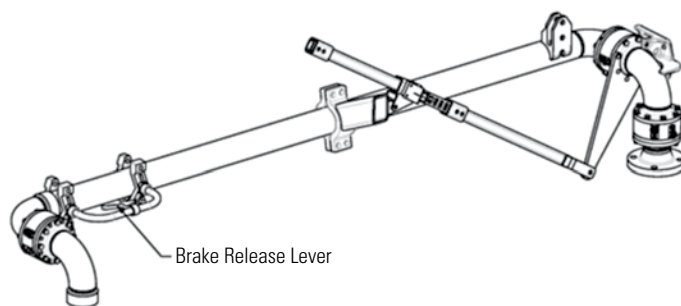

# 888L Loading Arm Lockdown Assembly

## OPTIONS

The 888L has several mounting options to cover a variety of applications. For vary viscous applications where there are concerns about material collecting within the brake-release handle, we offer a Cable Release option which releases the lockdown by simply pulling a cable.

We also offer a Manual option, which eliminates the cable entirely and instead relies on a manual pin to lock the arm in place. This option may make sense when looking at extremely high load applications.

### **Lock Down: 888L Cable Release**

The cable release 888L lock-down design does not require the brake-release lever, cable, cable housing and associated components. The above assembly process for the brake-release lock-down can be followed.

Insert the cable through the remote control lever and then through the rocker assembly.

Inspect the arm for proper operation.

### **Lock Down: 888L Manual Release**

The cable release 888L lock-down design does not require the brake-release lever, cable, housing and associated components. The above assembly process for the brake-release lockdown can be followed.

Insert the locking pin through the rocker assembly and then through the inner tube assembly.

Install one end of the wire rope around the locking pin handle and crimp with the swaging sleeve. Install the other end of the wire rope around the pipe-collar bracket.

Inspect the arm for proper operation.

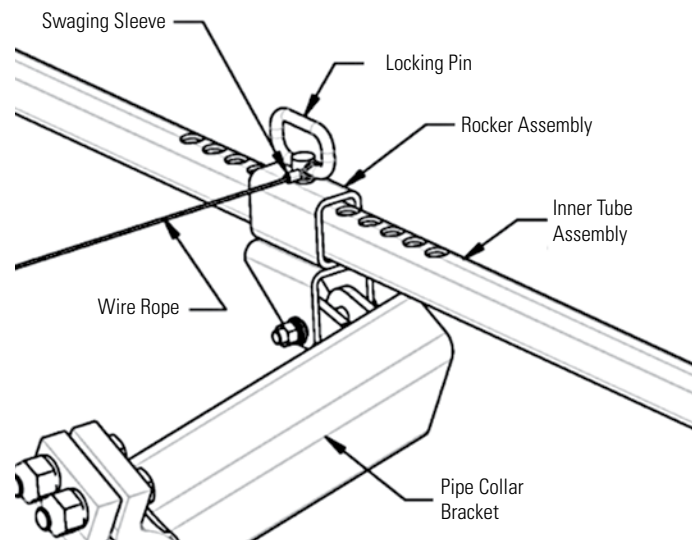
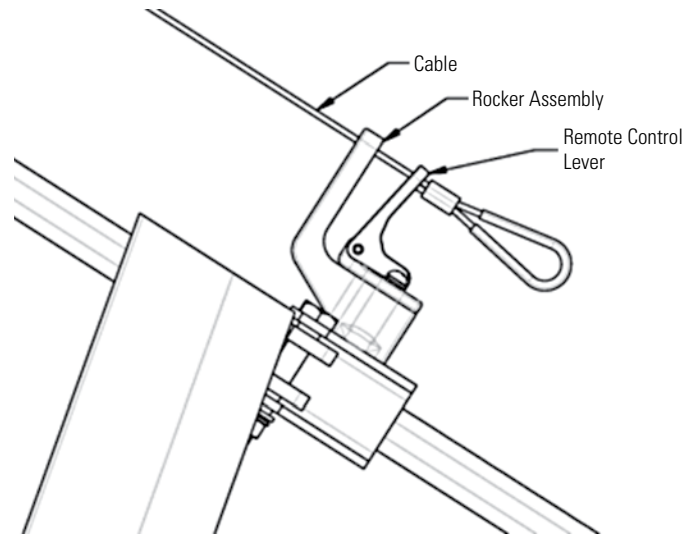

**IMPORTANT:** OPW products should be used in compliance with applicable federal, state, provincial, and local laws and regulations. Product selection should be based on physical specifications and limitations and compatibility with the environment and materials to be handled. OPW MAKES NO WARRANTY OF FITNESS FOR A PARTICULAR USE. All illustrations and specifications in this literature are based on the latest product information available at the time of publication. OPW reserves the right to make changes at any time in prices, materials, specifications, and models and to discontinue models without notice or obligation.

### **WARNING**

Failure to follow these warnings could result in serious personal injury, property damage or product failure.

1) While installing and using the Loading Arm, always wear adequate personal protection, including hard hats, gloves, and steel-toed work boots. Failure to wear adequate personal protection may cause serious personal injury and death.

2) Always follow the procedures prescribed in this document. Failing to follow the procedures prescribed may damage the Loading Arm and cause serious personal injury and death. Consult Loading Arm Installation, Maintenance & Safety Manual for more details.