

MATERIAL:  
IRON / ALUMINUM  
VITON

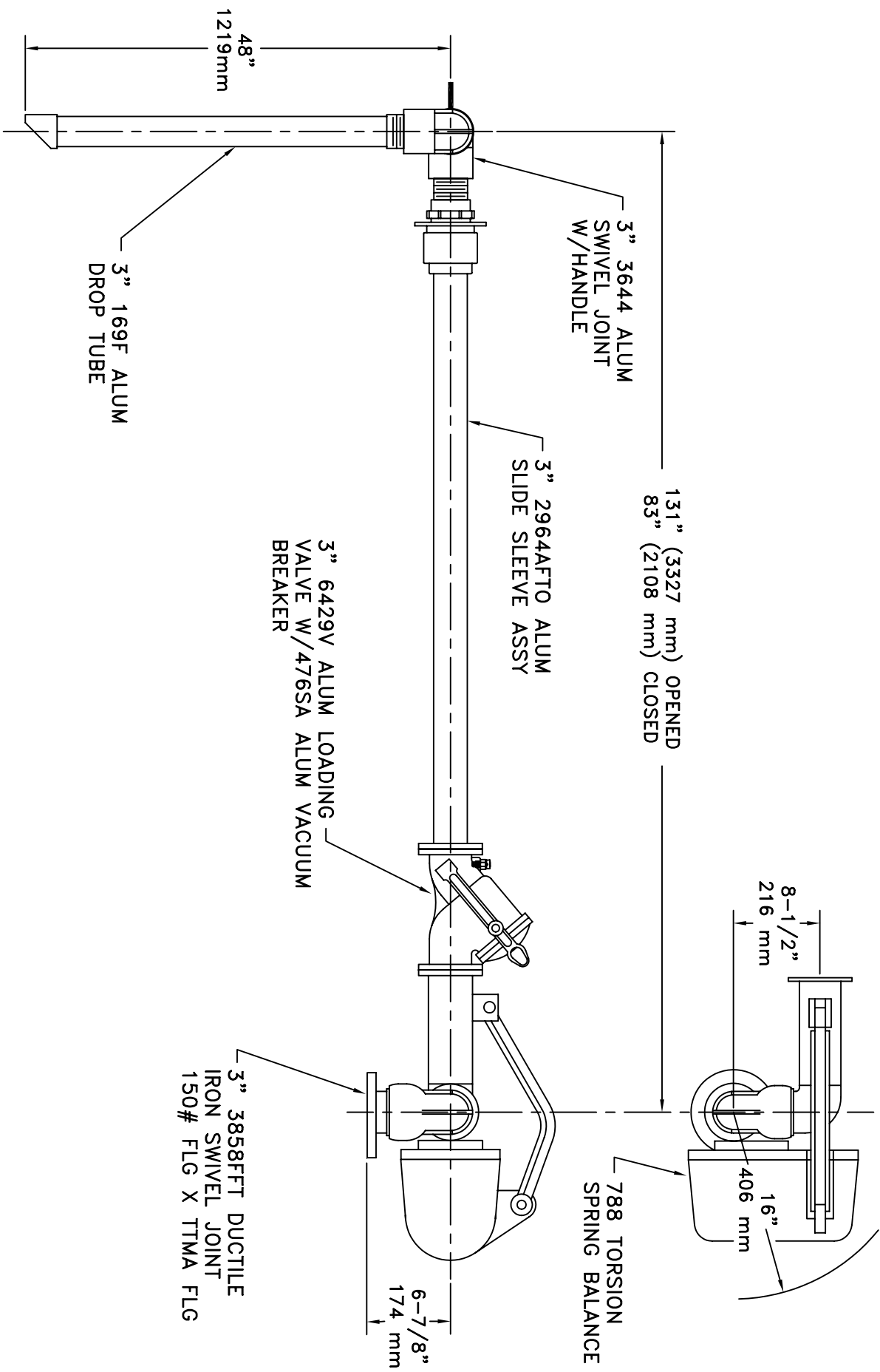

### 3" OPW A32F LIQUID LOADER



ARM IS DESIGNED FOR PRODUCT RETENTION TO POINT OF VALVE