

Operation Manual
OPW Engineered Systems
Rack Monitor 88xxE

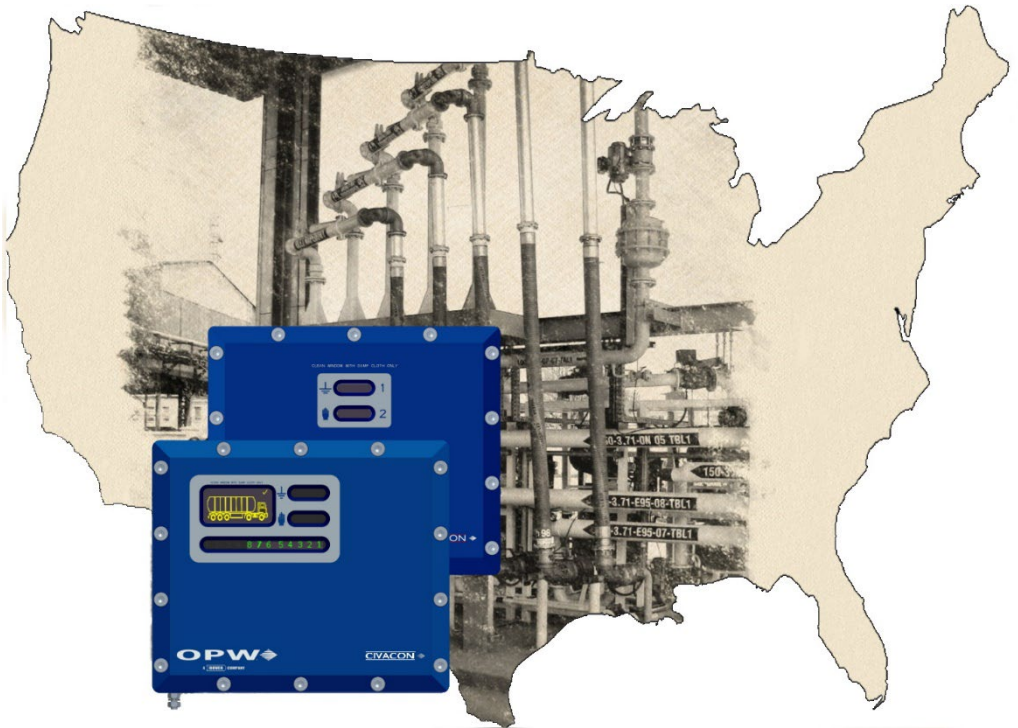

Disclaimer

This manual provides important safety and technical information of the OPW Rack monitor 88XX-series. It is important that this manual is read and understood completely by the installing technician prior to installation.

88XX is a secondary overflow prevention monitor for protecting loading operations from overflowing. It performs two functions i.e. grounding and overflow monitoring and is compatible with 2 and 5 wire optic probes.

OPW Fluid Transfer Group Europe BV OPW guarantees the customary normal quality and soundness of the items delivered during the guarantee period and that this product is adequate for the stated use in chapter 0 and is in accordance with the Directive(s) stated in the declaration of conformity in this manual.

OPW Fluid Transfer Group Europe BV cannot be held responsible for incorrect use of the RACK MONITOR 88XX. The Rack Monitor 88XX is for the use of monitoring of loading of tank trucks with the application and parameters stated in chapter 0 of this manual.

In case this OPW Rack Monitor 88XX is used in another location then mentioned in the initial quotation or is abused, all guarantees will be declined.

This installation manual is an integral part of the supplied product and must at all times be supplied with the Rack Monitor 88XX when it is relocated or sold to a third party. All pages of this manual must be in accordance to the table of contents. If not, please contact **OPW Engineered Systems**.

© COPYRIGHT 2023. The design, drawings and documentation are the exclusive property of **OPW Fluid Transfer Group Europe BV**. It is submitted on the condition that the designs contained therein are held confidential and is subject to return on demand.

Apart from exceptions provided by the law, nothing from this publication may be duplicated and/or published by means of photography, microfilm, storage in computer files or otherwise, which also applies to full or partial processing, without the written consent of **OPW Fluid Transfer Group Europe BV**

Although the utmost care has been taken with this publication, errors and omissions cannot be entirely excluded. The **OPW Fluid Transfer Group Europe BV** therefore accepts no liability, not even for direct or indirect damage, occurring due to or in relation with the application of publications issued by **OPW Fluid Transfer Group Europe BV**

This is an **OPW Fluid Transfer Group Europe BV** product.

For technical assistance, information and/or complaints contact:

OPW Engineered Systems

Visiting address:

9393 Princeton Glendale Road

Hamilton, Ohio 45011

PHONE:: 513-932-9114 or 800-547-9393

FAX: 513-932-9845 or 800-245-8536

E-MAIL: Civacon.Sales@opwglobal.com

WEB: <http://www.opwglobal.com/opw-es>

or <http://www.opw-es.com>

OPW Fluid Transfer Group Europe BV

Visiting address:

Roggestaat 38

2151BC Nieuw Vennepe

PHONE:: +31 (0) 252-660300

E-MAIL: ams-sales@opwglobal.com

WEB: <http://www.opwglobal.com>

Mr. Edwin Smit

Managing Director

Warranty

All parts and products are thoroughly inspected and tested from the time raw material is received at our plant, until the product is completed. We guarantee that all products are free from defects in materials and workmanship for a period of one year from the date of shipment. Any product that may prove defective within said one year period will, at our option, be promptly repaired, or replaced, or credit given for future orders. This warranty shall not apply to any product which has been altered in anyway, which has been repaired by any party other than an authorized service representative, or when such a failure is due to misuse or conditions of use. We shall have no liability for labour costs, freight costs, or any other cost or charges in excess of the amount of invoice for the products.

THIS WARRANTY IS IN LIEU OF ALL OTHER WARRANTIES, EXPRESS OR IMPLIED, AND SPECIFICALLY THE WARRANTIES OF MERCHANTABILITY AND FITNESS FOR A PARTICULAR PURPOSE.

Approvals

The 88XX OPW-ENGINEERED SYSTEMS Loading Rack Monitor is suitable for Ex 2(1) G Ex db [ia Ga] IIB T4 Gb Class I, Division 1, Groups C & D hazardous locations with intrinsically safe outputs, and housed in an Explosion Proof Enclosure. All monitors are ATEX / IECEx / QPS approved. Please consult the factory for the availability of special models.

IECEx: Ex db [Ex ia] IIB T4 Gb

ATEX:  Ex db [Ex ia] IIB T4 Gb

Canada: Ex db [Ex ia] IIB T4 Gb; [Ex ia] Class I, Division 1, Groups CD, T4

US: Class 1, Zn 1, AEx db [Ex ia] IIB T4 Gb; [Ex ia] Class I, Division 1, Groups CD, T4

Technical assistance in the U.S.A.

If at any time during the installation a question arises that is not covered in this Installation Instruction, or with any other applicable documents referenced, feel free to call the

OPW-ENGINEERED SYSTEMS – ELECTRONICS TECHNICAL ASSISTANCE LINE:

In the U.S.A., Call: 513-932-9114 or 800-547-9393

OPW-ENGINEERED SYSTEMS – CUSTOMER SERVICE DEPARTMENT:

In the U.S.A., Call 513-932-9114 or 800-547-9393

IN ALL OTHER COUNTRIES: Contact your local **OPW-ENGINEERED SYSTEMS** agent.

OPW ENGINEERED STSTEMS

9393 Princeton Glendale Road

Hamilton, Ohio 45011

PHONE:: 513-932-9114 or 800-547-9393

FAX: 513-932-9845 or 800-245-8536

Table of Contents

Operation Manual <i>OPW Engineered Systems</i>	1
Disclaimer	2
Warranty	4
<i>Approvals</i>	4
<i>Technical assistance in the U.S.A.</i>	5
Table of Contents	6
Specifications	9
Electrical Specifications	10
Inputs.	11
Outputs.	11
<i>External environment reminder (see installation manual for details)</i>	12
Product Description.	12
Sensors Types.	13
Sensors and Grounding.	14
Sensors communication	14
System operation.	17
Relay operation.	18
Flash pattern table:	20
Ground verification	21
Sleep mode.	21
Heartbeat.	21
Dipswitch setting. “System”	21
Oled Display 88x0E.	23
<i>Fault visualization</i>	24

<i>Power-up</i>	24
Normal operation.	25
Function keys	25
Bypass operation.	27
Operational Function (blue) key	27
Rack Function (Red) Key	29
Safe disposal Function Key	29
<i>Loading</i>	30
<i>A normal loading will end in one of the three possible situations.</i>	30
Example of a Loading cycle with ROM.	31
Example of a Loading cycle with 5-wire sensors.	32
<i>Explanation of used icons on the Display</i>	33
Faulty detected sensors.	35
Sensor detection.	35
Firmware upgrade.	37
Event log.	37
Communication settings.	37
Data communication.	37
<i>Civacon 8500/8800 Protocol</i>	38
Table 4	39
Table 5	39
Table 6	40
Table 7	40
<i>Modbus.</i>	42
<i>Current Modbus 88xx</i>	44
<i>Physical interface</i>	44

<i>Registers</i>	44
<i>Rack serial</i>	44
<i>Reset counts</i>	45
<i>Vehicle Id</i>	45
<i>Probe status</i>	46
<i>Rack status</i>	47
<i>Channel status</i>	47
<i>Date and time</i>	48
<i>SL rating.</i>	49
Supplied accessories.	49
Optional system accessories.	49
Maintenance.	50
Check Points.	50
Troubleshooting.	51
Annex A – Additional Electrical Drawings	53
Ask OPW for different connection diagrams e.g. dual socket or junction box	53
Annex B – Set clock	53
Annex C - Recommended Spare Parts	54
Annex C – Certificates	55

Specifications

The Rack Monitor 88xxE is a loading rack monitoring system, detects and communicates a pending overflow condition to the loading rack control automation equipment by means of a normally open relay contact. In addition this non-permissive condition as well as diagnostic information is displayed. A typical system contains loading rack control monitor (88xxE Rack Monitor) and a API 10 wire screened coiled cable with a black 10 pins 4 J-slot plug (Model 7400E).

Sensor signal inputs allow compatibility with the NEN-EN13922 and two other API standard signalling conventions commonly used in the industry. Either of these signals comes from the truck/trailer mounted onboard control monitor or sensors. The 88xxE rack monitor supersedes the 84xx,813x and 85xx type rack monitors and are suitable for hazardous locations with intrinsically safe outputs.

Not all depots are the same and sometimes extra functionality is required. The 88xxE has been designed to fulfil those extra functionality. Add-ons can be placed in spare sockets. E.g. a MODBUS add-on can be simply added to the existing rack monitor when required in a later state.

There are multiple versions available. (ask OPW for possibilities).

The 8851 is a most basic rack monitor for 5-wire sensor in the range. It can be set (by means of a dip switch) in the 8130 mode. In this mode the light-indicators react the same as the previous 8130 rack monitor.

The 8821 is designed to detect 2-wire sensors. **(Note 1)**

The Rack Monitor 8870E is a complete auto-switching version with Organic Led display.

The installation of all versions are the same.

NOTE 1: *Thermistor sensors are not supported!*

Thermistor sensors are heating elements with a temperature sensor.

A certain amount of power is applied to keep the sensor tip within a around ~75°C 167°F. Temperature will drop as soon as the glass tip comes in contact with fluid. These sensors are not commonly used anymore and are superseded with 2-wire optical sensors. (e.g 2-wire quick-start sensor).

See below for further explanation.

Electrical Specifications

Mains:

Nominal min. input voltage : 90 Vac.
Nominal max. input voltage : 250 Vac.
Nominal input current : 50 mA_{RMS} @ 230 Vac
Frequency : 50 / 60 Hz

Nominal power consumption : 15VA.

Mains current limitation
internal fuses : 1AT

Inputs.

Sensor	Terminal J5 Pin 1~ 8 : all EN13922 compliant sensors. : all industry standard format overflow detection sensors . Two-Wire sensor (maximum eight) . Five-Wire sensors (maximum twelve) . ROM 3205E & ROM II & ROM III On board monitor. : Dry sensor emulator (dummy)
Ground verification	Terminal J5 Pin 9 : Verification according EN13922 : Positive and negative sensing : Civacon Ground Bolt (GS1000) & Ground Wire (GS1001)
Truck comms	Terminal J5 Pin 9 : Tank truck data communication Electronic ID (CID-2000)
Secondary input	: J7 an intrinsically safe normally closed input. With different functions. Ask OPW for details

Outputs.

Permit Relay output

Voltage	: 250V ac/dc
Current limitations	: 2 AT Internal Fuses
Functional specs	: Form-A, Normally open safety relay contacts Energized when overflow sensors are dry and ground is verified

Auxiliary 1 Relay output

Voltage	: 250V ac/dc
Current limitations	: 2 AT Internal Fuses
Functional specs	: Form-A, Normally open relay contacts

Auxiliary 2 Relay output

Voltage	: 250 V ac/dc
Current limitations	: 2 AT Internal Fuses
Functional specs	: Form-C (SPCO) Auxiliary relay

Communications.

Contact OPW FTG for availability.

Miscellaneous.

Optional sockets	: expansion slots for additional functionality.
Real Time Clock	: precise trimmed Quartz real time clock. : clock is set to Greenwich Mean Time (GMT)
SD Ram socket	: Primarily used for Update Firmware : Secondly used for Time stamped data / event logging.

External environment reminder (see *installation manual for details*)

Operating Temperature Range (T_a)	: -45°C (-43°F) to +70°C (158°F)
Storage Temperature (T_s)	: -45°C (-43°F) to +70°C (158°F)

View angle display	: ~25°
Visibility display	: ~0.5m
View angle LED's	: 120°
Visibility LED's	: 20m (no direct sunlight)

Main Seal : Certified Silicon gasket. Use only OPW part H72542 as replacement.

- The gasket is attached or secured to bottom part to prevent loss, damage or incorrect assembly. The gasket material shall not itself adhere to the other joint face and has to be slightly greased.

Product Description.

This manual describes the operation, and troubleshooting of the Civacon 88xxE Loading Rack Monitoring System.

Read separate installation manual for wiring the rack monitor

It is intended to help operators, maintenance persons, and equipment specifiers understand the operation and standard features of the 88xxE Rack monitor

It is recommended reading this manual before installation of the equipment.

The 88xxE monitor is a loading rack monitoring system designed to offer a reliable and safe assistance when loading tank truck.

It can detect and work with a wide variety of overfill sensors but can also be set to accept only sensors conform.

EN13922 Tanks for transport of dangerous goods
Service equipment for tanks
Overfill prevention systems for liquid fuels

The 88x0E monitor is designed to interface with the user by means of a large multi languages OLED Display and 20 full color Light Emitting Diodes indicators (LED)
Clear and short messages will be shown on the OLED Display to explain the status of the overfill sensors, cabling and Rack monitor.

88xxE is used with Civacon high quality plug & cord set(s) either of the 73xx Series, Green (2-Wire / Therm.) Plug and 8 or 10-conductor straight or coiled cable; 71xx Series, Blue (5-Wire Optic Plug and 6 or 10-conductor straight or coiled cable; or EN1392 compliant 7400E, Black Plug and 10-conductor with screened #9 data conductor coiled cable, as local industry standards dictate. A junction box (Model 75xx Series) must be used for rigid conduit installations and must be ordered separately, or with a plug & cord kit. Passive (and active) storage plug storage hangers are also available.

Please consult the factory for the current availability of all optional products. Optic signal inputs allow compatibility with the European standard EN13922 as well as the two API RP-1004 standard signalling conventions commonly used in the industry. Either of these signals comes from the truck/trailer mounted onboard control monitor or sensors.

Sensors Types.

Two-Wire sensors.
Five-Wire sensors.

Sensors and Grounding.

Before continuing describing the functionality of the rack monitor a short explanation of the sensors and ground verification.

As mentioned above there are three industrial standard sensor principals.

Thermistor sensors are not commonly used therefore the 88xxE is not supporting this type of sensor.

To avoid misunderstanding this manual will refer to Two-Wire sensors (2-Wire) and Five-Wire (5-Wire) Sensors.

The sensing circuit of a 2 (and 5) wire sensor are not necessarily done with a optic detection circuit other detection principles are also used.

Two-Wire sensors can be used on vehicles with no more than eight compartments. Standard Gantry controllers are monitoring all 8 channels (see dipswitch setting for 6 channel US version). This means the remaining channel(s) on vehicles equipped with Two-Wire sensors with less than 8 compartments must be connected to an electronic Dummy (e.g. part number 1920). All sensors are individual wired / connected to the Rack monitor and more than one wet compartment can be detected at the same time.

The Five-Wire sensors are connected in series and therefore capable of handling more than 8 compartments. Because of this, only one wet compartment can be indicated at the same time. A special diagnostic wire is used to determine the wet compartment. The 88xxE can handle more than 12 compartments but only 12 will can be indicated on the LED display.
(Maximum 12 compartments according EN13922)

The 88xxE will try to determine which compartment is wet if a good connection is made between plug and socket and wiring are done carefully, the 88x0E shall indicate the correct compartment on the Liquid Crystal Display.

Note: Displaying the correct wet compartment is only possible if there are no bad connections.

Ground verification is done via pin 9 on the terminal and plug-socket connection. For NEN-EN13922 application pin 9 is also used for detecting if a Vapour recovery hose is properly connected to the Tank-Truck when five-Wire sensors are used.

Note: The Vapour recovery hose is checked via pin 8 on a Tank-Truck equipped with Two-Wire sensors in EN13922 compliant locations (only).

Note: Consult socket drawings for detailed information.

The 88XXE Rack Monitor is capable of detecting a resistive Ground connection as well as a Ground-Bolt (GS1000 or GS1001) connection on a Tank-Truck. Make sure connection between pin 9 and pin 10 via the Tank-Truck chassis is less than 1k Ω .

Sensors communication

882xE, 885xE and 887xE are able to communicate with the latest generation OPW overflow sensors (Civastar) as well as the 3205E Onboard Monitor, 1399TT Truck-tester and Civacommand

The 885xE and 887xE rack monitor will communicate via the existing wiring. Initiation of the sensors is done during power-up of the sensors. Initiating a 12 compartment truck with 5-wire sensors can take up to 30 Sec. since all sensors are connected in series (8 Sec. for a 6 compartment truck with 5-wire sensors). It will take a few Sec. for the 882xE and 887xE to read 8 x 2-wire sensors.

The ability to read the sensors opens new possibilities to ensure the most reliable pending overflow detection. E.g. serial numbers of the sensors are available for Tank-truck identification or a reminder to clean the sensor before the next loading, cycle or wet test the sensor before the next load. New sensors software releases will have more available data, please contact OPW for details.

Table 1

Test conditions				Emulation			
GOOD	NO GROUND	SENSORS		Upper Window	Lower Window	Upper Window	Lower Window
		WET	DRY				
	X			BURST BLUE	OFF	FLASH RED	FLASH RED
	X			FLASH RED	FLASH RED	FLASH RED	FLASH RED
	X		X	FLASH RED	FLASH GREEN	FLASH RED	FLASH RED
	X		X	FLASH RED	FLASH RED	FLASH RED	FLASH RED
X				FLASH WHITE	OFF	ON RED	ON RED
X			X	FLASH WHITE	FLASH RED	ON RED	ON RED
X			X	FLASH WHITE	FLASH GREEN	OFF	ON GREEN
X			X	FLASH WHITE	FLASH RED	ON RED	ON RED
		X		FLASH WHITE	FLASH RED	Not allowed	
		X		FLASH YELLOW	FLASH RED	Not allowed	
		X	X	FLASH YELLOW	FLASH GREEN	Not allowed	
	X			FLASH RED	FLASH RED	FLASH RED	FLASH RED
X			X	FLASH WHITE	FLASH YELLOW	ON RED	ON RED
			X	FLASH WHITE	FLASH YELLOW	ON RED	ON RED
Additional Functions							
SLEEP				OFF	DIMMED FLASH	RED FLASH	OFF
ACK FUNCTION KEY				ON BLUE	OFF	ON BLUE	OFF
SYSTEM ERROR				FAST FLASH	COUNT RED	FAST FLASH	COUNT RED
SMART SOCKET OK				DIMMED FLASH	DIMMED FLASH	DIMMED FLASH	DIMMED FLASH
SMART SOCKET NOT OK				DIMMED FLASH	DIMMED FLASH	DIMMED FLASH	DIMMED FLASH

System operation.

The purpose of the Civacon 88xxE Rack Monitor liquid level sensing system is to detect a liquid point level signal from a sensor mounted in compartments of a tank truck, or storage tank. The system provides an automatic signal to the rack automation equipment to shut-off the flow of liquid and warn of an impending overflow condition of a tank truck or storage tank. It can detect up to 8 Two-Wire Sensors or 12 Five-Wire Sensors

As soon as the power is supplied, the monitor will perform an extensive self-test of its internal functions (see power up test). If one of the test fails (except Led Test) a message will be shown on the OLED Display (88x0E only). Also a red Led indicator will blink. (see troubleshooting chapter for details).

Make sure no vehicle is attached at power-up.

Note: The cable and plug connections shall be tested continues if an active storage hanger is used.

If all tests are passed the rack monitor is ready for use.

The first task of the 88xxE Rack Monitor is to ensure proper grounding is established via Pin 9 and pin 10 of the plug socket connection to the tank-truck chassis. Or a low impedance between the two jaws of the clamp (MODEL 7720) or the pins of the plug assembly. (MODEL 7620).

As soon as this has been ensured, two white Led indicators will flash inversely or in case of the 88x4E the TOP light bar . (see Table 1 for light patterns)

Secondly the 88xxE will check for shorts between sensors and shorts to ground and for open circuits for every channel.

Then the 88xxE Rack Monitor (887xE only) will determine sensor type and the amount of compartments.

It can detect up to eight Two-Wire sensors, up to 12 Five-Wire sensors and is fully compatible with the 3205E On board Retain Overfill Monitor.

If possible, the amount of sensors will be shown on the Display and Led indicators. (see sensor detection chapter for details).

The 887xE Rack monitor provides an "Auto switching" capability between 2-Wire sensors and 5-Wire sensors.

If sensor type is selected, all sensors are dry and proper ground is verified the 887xE Rack monitor will communicate a Permissive condition to the automation equipment. The monitor can only be connected to one type of signal source at any one time. You cannot have a mix of 2 & 5-Wire sensors connected at the same time.

The 88xxE Rack Monitor systems uses self-checking principles to provide a continuous check on all system components.

It depends on the dip switch setting if the detected shorts are of influence of the PERMISSIVE signal.

e.g. If the 88xxE rack monitor dip switch is set to EN13922 then NO shorts between channels are allowed

If at any time the 8800E Rack Monitor detects any kind of failure, a signal to the automation equipment will be send to shut-off the flow.

All sensor failures are indicated on the two possible displays. 88x0E and 88x1E

The 88x1 is equipped with two simple multi-color light bars.

Default factory setting of the light pattern is according the light pattern of the 8130 rack monitor. (see Table 1 for details).An second light pattern can be set via dip switch settings (see DIP Switch settings for details)

Relay operation.

This rack monitor is standard equipped with three relay outputs.

1. The normally open Permit relay will switch if all sensors are dry AND a good ground connection is detected.
2. The normally open AUX 1 relay is by default used as a secondary safety relay. This relay will switch on just before the Permit relay switches on. When a wet sensor or bad ground is detected the Permit relay will switch off and the AUX1 relay will switch off a fraction later. The physical state of the Permit relay is monitored. The monitor will go into an error state if the Permit physical state of the relay differs from the electrical state. The AUX1 relay will stay in the OFF position as long as the rack monitor is in this error state until power has been switched off and on. Above sequence is built-in to detect and protect "burn-in" of contacts during switching from permit to on-permit and v.v.

(Connect both Permit and AUX1 in series to increase functional safety.)

The AUX1 relay will be used for secondary shutdown if a second sensor detection PCB is placed.

In this case the secondary sensor detection is used for redundancy and contacts of AUX1 should be wired separately to the terminal automation installation.

The AUX1 relay can be utilized for additional functions. Please contact OPW for possibilities

3. A user selectable (normally open - common - normally closed) AUX2 relay is available for four predefined functions.

See table at Figure 2 for dipswitch settings.

Front layout.

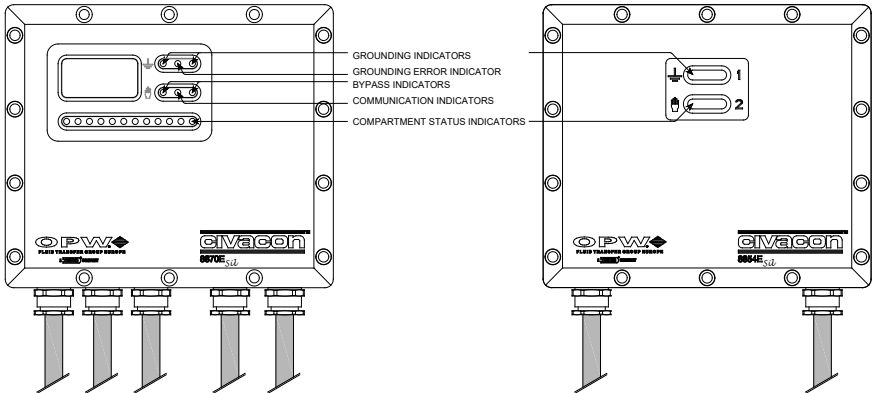

Figure 1 (Shown with cable glands. 88xxN models use rigid conduit)

Above a the two models Rack Monitor, a 88x0 and a 88x1. The 88x1 has two multicolor light bars.

The top light bar is usually used to indicate if a proper ground connection of the tank truck has been established.

The bottom bar is mainly used to indicate the status of the sensors.

Indication pattern depends on dipswitch setting 1-6. If this switch is on (up position) than the light pattern is according the 8130 rack monitor. In Figure 2 the monitor indicators of a 8130 are shown.

MODEL		8130			
OPERATORS					
TEST CONDITIONS		NO GROUND	GOOD GROUND NO OPTIC	GOOD GROUND GOOD OPTIC	BYPASSED
	RED 1	ON FLASH	ON	OFF	ON
	GREEN 2	OFF	OFF	ON	ON

Figure 2

Note a 8130 is a simple 5-wire rack monitor.

Red indicator ON means NON-PERMISSIVE; while a Green indicator ON means Permissive. Both Red and Green will be on when the bypass is activated.

The Red lamp will flash if there is no GROUND VERIFY signal.

Monitor indicators react differently if the dipswitch setting (1-6) aren't set and in the default off position.

A LED test will be started after power-up.

There should be nothing connected at power-up.

An system error pattern will be shown if sensors are connected during power-up.

Top bar flashing Red and Bottom bar will flash code 13 (see flash pattern table below)

Flash pattern table:

It is recommended to use a 88x0E rack monitor to minimize downtime in case of an error. The 88x0E rack monitor is equipped with a OLED display and 20 multi-color LED indicators to visualize the status of the Rack monitor, Tank truck and sensors. The 88x1E is not equipped with and display and 20 multi-color LED indicators and has only two multi-color light bars. Flash and color patterns are implemented to visualize the status of the 88x1E rack monitor, Tank truck and sensors.

If the 88x1E is not in the 8130 emulation mode then the following light patters are used:

Long and short light pulses are indicating a number. A short ($\frac{1}{2}$ Sec.) pulse is 1 and a long ($1\frac{1}{2}$ Sec.) pulse is 5.

The pause between pulses is a $\frac{1}{2}$ Sec. and the pause between iterations is 2 sec.

e.g. a short pulse is 1. Two short pulses is 2. Etc. A long pulse followed by one short pulse is 6.

This flashing pattern is used to indicate the amount of dry sensors.

e.g. an 11 compartment tank truck is equipped with 5-wire sensors. If all sensors are dry then the Bottom light bar will flash Green : 2 times long and 1 short pulse.



If a sensor becomes wet then the Bottom light bar will flash Red, indicating which compartment has a pending overflow.

e.g. Compartment 7 becomes wet then the Red bottom light bar will flash one long and two short pulses.

This light pattern is also used to indicate a few systems errors.

Not all error codes are indicated since it will be too complicated. Please consider a 88x0E rack monitor for all possible Rack monitor, tank truck and sensor errors.

e.g. the rack monitor calibrates the inputs during power-up.

Therefore nothing can be connected during calibration. The rack monitor will show an error code "13" if it detects a load on the pins during power up at the Bottom light bar. Top light bar will flash fast ($\frac{1}{4}$ Sec. on and off) to indicate an error

Table 2

Ground verification

The rack monitor will verify the impedance between pin 9 and 10 (including ground bolt) or if a clamp (model 7720) is used between the two jaws or the two pins of or ground plug Model 7620. Ground verification is set if the impedance is within the set boundaries. The Top bar will flash white for ½ Sec. on and off.

Sleep mode.

The rack monitor will enter sleep mode when there is nothing detected for 15 minutes. The Top light bar will be off. The bottom light bar will light up Red with an intensity of 50% for 3 Sec. then 10% for 27 Sec.

Heartbeat.

A Blue light will appear at the Top Bar to indicate that the rack monitor is running, this will only appear when there are no other flash patterns.

Dipswitch setting. “System”

Two switch arrays are placed on the main board. Due to software upgrades not all switch settings are explained in this manual. Underlined = Default

Switch 1	Switch 2		<u>Function</u>	Remarks
Off	On		Signal settings according EN13922	Strict settings
<u>Off</u>	<u>Off</u>		Signal settings according <u>Rest Of the World</u>	Medium tolerant settings
On	Off		Wide Signal settings	Most tolerant settings
On	On		Settings / behaviour according 8130	
Switch 3				
<u>Off</u>			8 compartment 2-Wire Top sensors selected	
On			6 compartment 2-Wire Top sensors selected	Note *1
Switch 4	Switch 5	Switch 6	Aux 2 Relay (nc-c-no)	
<u>Off</u>	<u>Off</u>	<u>Off</u>	Disable	
On	Off	Off	Top Sensors dry and Ground verified	
Off	On	Off	Top sensors Dry	
On	On	Off	Ground verified	
Off	Off	On	Smart socket permit	
On	Off	On	Reserved	
Off	On	On	Reserved	
On	On	On	Reserved	
Switch 7				
<u>Off</u>			Right side drive, drawn truck with compartment 1 to the left	65% of the world
On			Left side drive, drawn truck with compartment 1 to the right	35% of the world

The 88xx rack monitor is designed to fulfill maximum safety. Therefore the rack monitor will try to detect all possible errors/faults when in EN13922 mode. One of the possible errors/faults is shorted channels / wires. The 88xx continuous monitoring possible shorts between channels / wires and switch to non permissive when detected. In some cases a on truck monitor (ROM) is used. All sensors are wired to this onboard monitor. The output of the onboard monitor is connected to the socket and during loading to the 88xx rack monitor. The output of the onboard monitor can be emulating 2-wire sensors or 5-wire sensors. Only 2 channels are normally connected to the socket. The remaining 4 (or 6 in 8 compartment truck) must be connected to a dummy. But in some cases the remaining channels are connected to channel 1 or 2 (wit a short between 1.3.5.8 and 2.4.6.7).

Those two channels will/can be high impedance (open) when the onboard becomes NON-Permissive. Depending on the dip switch setting of SW8 the 88xx rack monitor will show wet or open channels detected.

Swich 8
 Off Show open channels
 On Hide open channels

The text "ROM" will be shown in the left-bottom corner when SW8 is set to ON

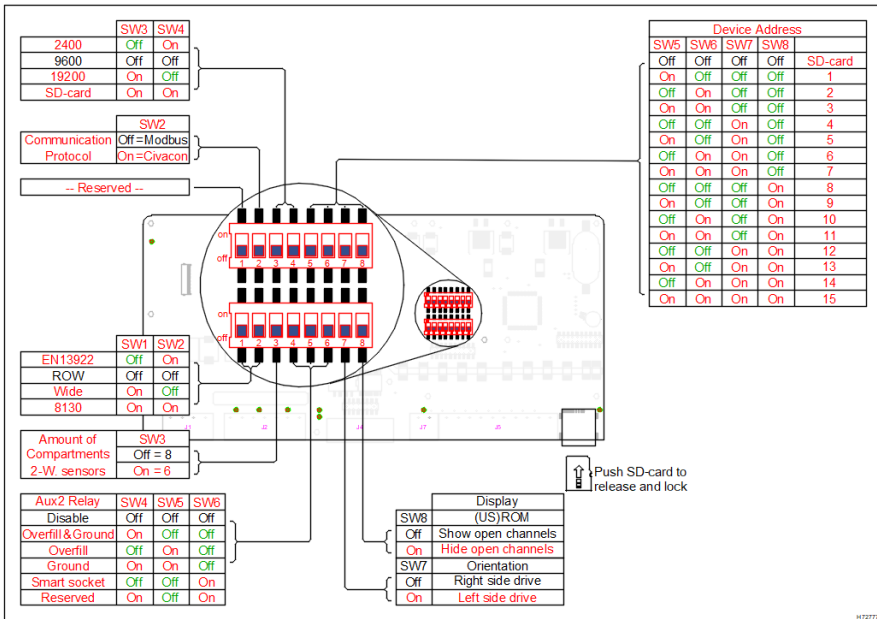

Figure 3

Note * EN13922 selection will be ignored if set to 6 compartments.
 Incompatible settings error will be generated when "signal setting according EN13922" is also selected.

Oled Display 88x0E.

The 88x0E is fitted with an 2,7" Oled display with a temperature range between -45°C (-43°F) and +70°C (158°F) 12 multicolor Light Emitting Diode (LED 1~12) indicators are placed in the bottom window to indicate compartment status. The right middle window is used to indicate the bypass status and read the function key. The top window indicates the status of the ground verification (LED 15 and 19).

A flashing white light indicates a good ground. LED 15 and 19 are off if the impedance between the truck and ground is too high.

The bottom bar (LED 1 to 12) will flash Red/Green if the ground is outside specifications but sensors are dry.

Blue blinking light (LED16 & 18) are used as a heartbeat to indicate that the system is running.

The graphical display will only show minimal information during normal operation. More information will be shown if needed.

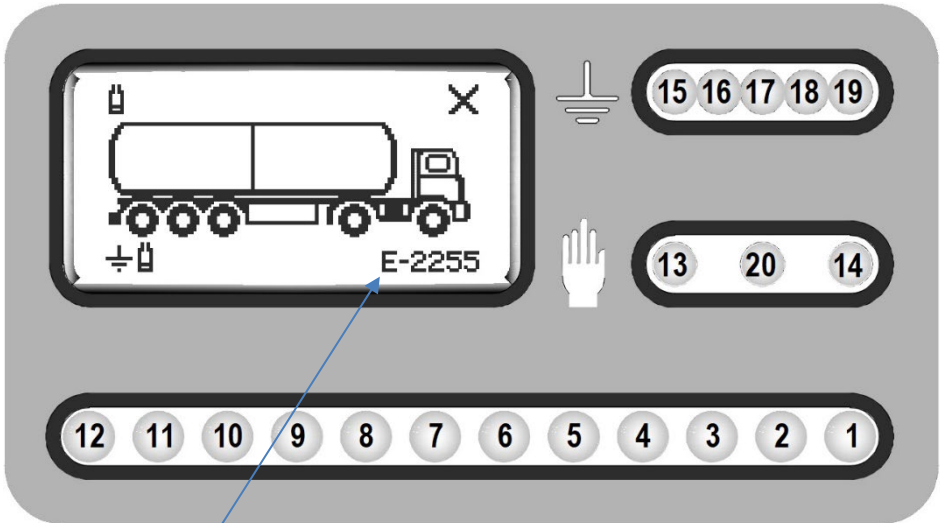
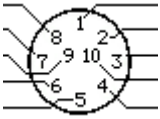

Figure 4

A 4 digit number appears if possible in case of an error except when the monitor is in sleep mode.

A brief explanation of error codes are shown in Table 3.

Fault visualization



A rear view of the plug is shown in Figure 5. To indicate possible location of the fault

E.g. The monitor detects a signal on pin 9 which is "out of range". will appear on the screen with a "?" besides pin 9 and a "!" at pin 1~8

Figure 5

This rear view will also be used in combination with a Smart Storage Hanger. Detailed information can be found in the Manual of the Smart Storage Hanger.

Power-up

The 20 Light Emitting Diodes will be sequentially lit at start up.

The software and hardware version are shown on the graphical display as well as Time and Date.

In addition a Config version can be shown.

By default the Time (HH:MM:SS) and Date (Day:Month:Year) will be Greenwich Mean Time. (see annex C how to set clock)

The rack monitor will ready for use if all internal test are positively completed

Then a short animated icon of a plug-socket connection will be shown until the plug is connected to the socket of the truck.

A few possible scenarios are possible after connecting the plug to the tank-truck socket.

1. All sensors are dry and a proper grounding is detected.
2. One or more sensors are wet and proper ground is detected.
3. All sensors are dry but the impedance of the grounding is too high.
4. Open or shorted channels are detected.
5. Sensors out of specifications are detected.

Note: Above information will also appear if the plug is not connected to the tank truck. This is mainly caused by shorts in the cable/plug or an internal error in the monitor.

1. Below an example of a Tank truck with dry compartments 2,5-wire sensors or ROM and good ground.

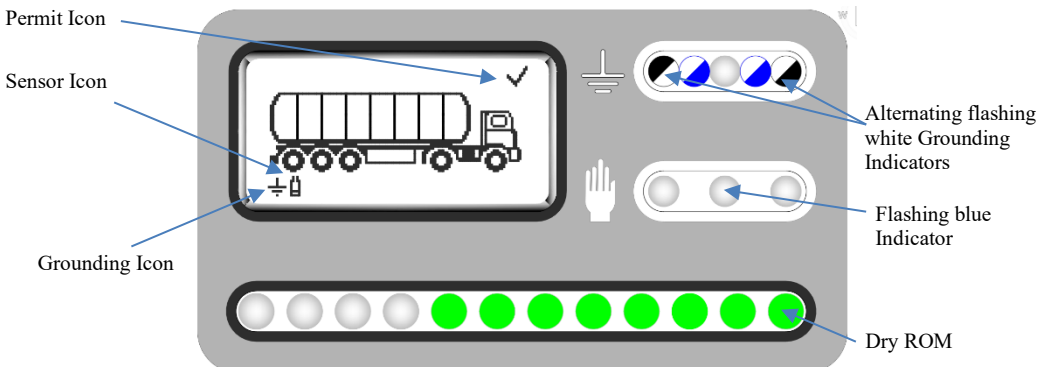

Note: Tank-Truck shown at loading side for or Left-Hand-Drive. See Dip switch 7 for setting

Normal operation.

The main task of the 88xxE Rack Monitor is to provide a signal to the rack automation equipment to shut-off the flow of liquid as soon as a sensors in a compartment tank detect a liquid point level

When the rack monitor is not used for 15 minutes it goes into sleep mode. During sleep mode the Red Led indicators will be dimmed and occasionally flash with high intensity to indicate "system ready in sleep mode".

As soon as the Plug is connected to the truck socket or removed from the active storage hanger the system awakes and is ready for use. If proper ground and dry sensors are detected the rack monitor will switch to permissive. When the loading is finished and the plug is removed from the truck it will wait 15 minutes before it goes back to sleep.

Function keys

To use the Function Key in a hazardous environment the following directives are applicable. The versions will be available with different colors and different functionality. This to give certain level of authorities within organizations and their needs for safety procedures.

Specifications inside Function Key Enclosure

Internal Pressure	: 80 kPa (0.8 bar) to 110 kPa (1.1 bar) (atmospheric pressure)
Ignition Energy	: ≤0.06 mJ (for electrical apparatus of Group IIB)
Internal Connections	: Earthing or equipotential bonding
Expected Lifetime battery	: 4 years stand-by

Specifications external environment

Usage Temperature Range (T_u):	-45°C to +40°C
Storage Temperature (T_s)	: -20°C to +40°C
Max. Surface Temperature (T_4)	: ≤135°C
IP Class closed	: IP54 acc. to IEC 60529
Resistant to	: UV Light (within Sun light), Corrosion, Ingress of Gasoline vapors and liquids (Diesel) Exhaust fumes, All other weather conditions Explosive Mixtures
External Pressure	: 80 kPa (0.8 bar) to 110 kPa (1.1 bar) (atmospheric pressure)
Air	: Normal oxygen content, typically 21% v/v

General Specifications

Outline dim. Function Key	: Max. width x length x height = 20 x 65 x 15 mm
Material Housing	: Polycarbonate
Max. capacitance	: 15 pF
Surface Resistance	: < 1GΩ at (23±2)°C and (50±5)% relative humidity
Weight	: 13 gr. (0.45 ounces)



Directive Compliance:

ATEX : II 2 G Ex ia IIC T4

The Function Key Rack Monitor 88xx is designed according to the following standards.

Use of Standards:

EN 60079-0	<i>Electrical apparatus for explosive gas atmospheres – Part 0: General requirements</i>
EN 60079-11	<i>Electrical apparatus for explosive gas atmospheres Intrinsic safety 'I'</i>
EN 60529	<i>Degrees of protection provided by enclosures (IP Code)</i>

Bypass operation.

Although it is not recommended, the 88xxE can also be bypassed in a faulty or wet sensor condition.

If the monitor is NOT set to EN13922 then shorted between channels can be bypassed. Shorted channels to ground cannot be bypassed with the blue key.

A special bypass key (red) has to be used to switch the 88xxE in total bypass mode.

Open and shorted channels can be bypassed but only if a proper earth connections has been established and earth can only be bypassed when all sensors are dry.

Special provisions should be made to make sure the truck with the compartments are able to discharged the build-up static electricity.

If the monitor is set to emulate the 8130 then, for extra safety the bypass function will be active for 40 minutes. The rack will switch to nonpermissive if the bypass trimer has expired.

The 88xxE bypass routine is able to bypass more than one event ("stackable" bypass).

This means every time a non-permissive situation occurs (except ground verification) the rack monitor can be set back to permissive to load by placing the bypass key in the designated location (see above for details).

The wet or faulty condition will stay visual until the plug is disconnected from the truck socket.

Note: The 88xxE Rack Monitor will revert to normal operation as soon as the plug is disconnected from the truck and ready to service the next load.

Operational Function (blue) key

It might happen that during use of the Rack Monitor 88xx some functions must be bypassed to continue working.

For examples :

- Wet sensors,
- Out of specifications,

The procedure to Bypass the (above) operations is as follows:

A symbol, a small hand on the Function Key indicates the active area of the key. This symbol corresponds with the small hand in the middle bar of the Rack Monitor 88xx

To activate the key it has to be placed in the corresponding slot marked with a small hand. Make sure hand next to the slot middle bar stays visible

As soon as the Rack Monitor receives a valid infrared signal the two blue indicators in the second bar will change from flashing to a steady light for 3 seconds. Function key will also be shown at the upper-left corner of the display. (88x0 version Only).

The received data is processed and the necessary action will be taken. If the Rack Monitor enters the bypass function two yellow LED indicators behind the Function Key will start flashing. The key can be removed as soon as the Blue indicators restart flashing.

Any additional use of the Function Key is not shown on the yellow indicators once the Rack Monitor has entered the Bypass Function (stackable bypass)

Stackable Bypass function.

This stackable Bypass function differs from the bypass function of all our previous Rack Monitors.

It will Bypass the occurred error instead of bypassing the Rack Monitor.

For example compartment 2 of a tank truck equipped with 2-Wire sensors becomes wet during loading. The Rack Monitor will switch to Non-permissive, trying to avoid an overfill situation. The loading arm connected to compartment 2 must/will be disconnected and the adaptor closed. At this moment the overfill detection of compartment 2 can be bypassed with the blue key. The wet sensor at compartment 2 will be ignored and as soon as a another compartment sensors becomes wet it will shut down again. This can be done until all sensors are Bypassed.

This is of course only possible with 2-Wire sensors. With 5-Wire sensors individual Bypassing of wet sensors is NOT possible.

Bypassing can be done for every operational related errors but not for ground verification.

Also for all non-operational errors like shorts, open wires and broken sensors. (see above)

Caution: Bypassing is not always allowed and code of practice or local laws must be observed.

According EN13992 bypassing is NOT allowed and therefore the Rack Monitor will ignore the function key

Rack Function (Red) Key

The Rack Monitor 88xxis also shipped with a Red Function Key. This key should never be used for normal operation. This key is only needed as last resort to energize the permissive or ground verification relay.

The procedure to Bypass the Rack Monitor 8800E/8801 is the same as the Blue Function Key.

**The Red Function key will bypass all detected errors/faults.
Working sensors and or good grounding will be monitored.**

Make sure supervision is available when a Function Key is used.

Never should this be done when no special precautions are made. Make sure the tank truck is properly grounded. In addition a different diagnostic display will appear with all important sensor data

Safe disposal Function Key

This device is marked according the European directive (2002/96/EC) on Waste Electrical and Electronic Equipment WEEE.

(Disposing of spent batteries/accumulators in the household waste is prohibited!)



Loading

A tank truck with will be shown briefly as soon as the monitor has established type and in case of 5-wire sensors amount of sensors. If 2-wire sensors are connected then the amount of detected compartments are always 8 or 6 (depending on dip switch setting: see Figure 2).

A timer will be started and shown in the centre of the screen. This timer is only indicating the loading time.

A normal loading will end in one of the three possible situations.

1. The loading cycle has been finished and no overfill has been detected.
2. The loading cycle has been ended due an wet sensor.
3. Or emergency switch has been pressed. (read Secondary Input chapter for settings).

1. Loading can also be interrupted when the monitor detects an internal or external fault. e.g. power supply failure as internal fault and broken or loose wire as external fault.

- A. The plug can be disconnected when the loading has been finished.
- B. The monitor will return into its default state. And the “*connect plug to socket*” animation will be shown.

Display will return to “sleep mode” if the monitor is unplugged for more than 15 minutes.

2. A wet sensor has interrupted the loading cycle to prevent a pending overfill.

After this there are two possible scenarios:

- A. The function key can be used (if not set to EN13922 mode, see EN13922 for details)
- B. Loading cycle will be stopped by disconnecting plug from the tank truck

3. Emergency switch has been pressed.

In this case also two possibilities:

- A. The function key can be used to reset the emergency detection.
- B. Loading cycle will be stopped by disconnecting plug from the tank truck.

In case of 2.A “use of function key” (e.g. 8 x 2-wire sensors are installed sensor in comp. 3 is wet).

Display will show a full compartment 3 and sensor LED indicator 3 will steady on. All other 7 will flash red.

One sensor has interrupted the loading and can be bypassed (in non-EN13922 mode).

In the left corner of the display (88x0 only) a sensor will appear to indicate bypassed sensor.

Only

When the rack monitor is not used for 15 minutes it goes into sleep mode.

During sleep mode the Red Led indicators will be dimmed and occasionally flash with high intensity to indicate “system ready”

Example of a Loading cycle with ROM.

Symbol (any color) below means flashing Light Emitting Diodes

A solid circle means LED indicator are solid on.



Icons and compartments can also flash.

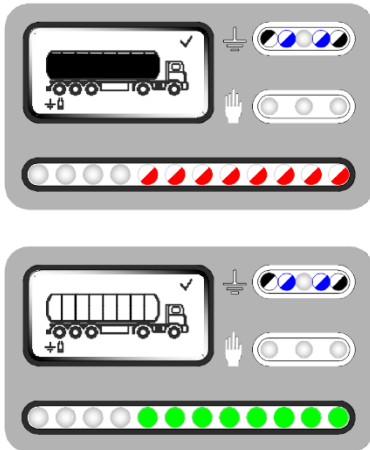

Figure 6

The rack monitor will display 8 wet compartments (Figure 6) since all channels are switching to non permissive at the same time (or 6, if switch 3 is set).

Note: The rack will monitor 8 channels if switch 3 is set to 6 compartments but 8 sensors are detected.

Top figure shows an truck with ROM or 8 dry 2-wire sensors shown by means of 8 Green indicators in the bottom bar and second sensor icon in the bottom left corner of the display. Two flashing white LED indicators in the Top-Right bar and icon on the bottom left corner of the display indicate that the ground connection is within specification.(low impedance)

The status of the permit output relay is shown in the upper right corner by means of a ✓ icon

Sensors are connected to a Retain and Overfill Monitor and the output of the ROM is connected to the socket. In most cases only two outputs are connected to the socket. Both outputs will switch to non permissive at the same time if the ROM detects product before loading or one of the Top sensors becomes wet.

Those two outputs are split into two sections. One output of the ROM is connected to pin 1,3,5 and 8 and the other output is connected to pin 2,4,6 and 7. (note: pin 1 and 2 are not connected in case of a 6 compartment truck).

In this case **switch 8** must set to display hide shorted channels (see Figure 2 for dip-switch settings).

The rack monitor will detect the shorted channels but will accept them as "ROM connected".

The rack monitor will display 8 wet compartments (Figure 6) since all channels are switching to non permissive at the same time (or 6, if switch 3 is set).

Figure 7

At this moment the function key can be used to accept and bypass the ROM.

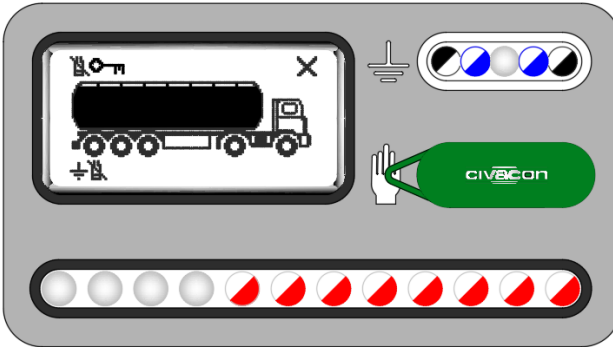

Place the function key as shown in the picture on the right at the middle bar. The two blue heartbeat LED's will be on for 3 seconds to indicate that the monitor has validated the key and a key icon will be shown on the top line of the display.

Compartment 1 to 8 on the display will stop blinking and show the compartment as full.

Two flashing yellow

indicators in the middle bar will indicate that the monitor is partial bypassed. This is also indicated by the sensor icon in the top left corner.

The status of the permit output relay will change from X to ✓

Note. In some cases the sensor becomes dry when the loading has been interrupted. In this case the indicator will stay RED

Example of a Loading cycle with 5-wire sensors.

Symbol (any color) below means flashing Light Emitting Diodes



A solid circle means LED indicator are solid on
Icons and compartments can also flash.

Indications and bypass possibilities are limited when 5-wire sensors are connected. These limitations are caused by the 5-wire sensor principle. The sensors are connected in series and all sensors connected after a wet sensor will be disabled, therefore bypass is not possible with one (or more) wet sensors.

The led pattern and display of a 8870 monitor will be identical of the pattern of a monitor with 2-wire sensor connected.

The figure at the top of this page shows a 8 compartment tank truck with dry sensors and verified grounding.

The second figure will appear as soon as one sensor becomes wet, in this example sensor in compartment 3.

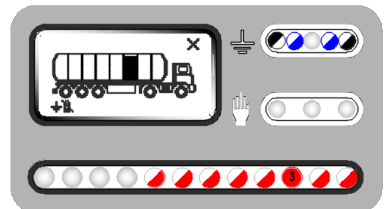
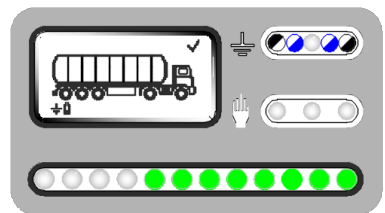

The indicator of the wet compartment (3) will be solid on and all remaining dry sensors indicators will flash red to emphasize the non-permit status of the monitor. Shown by the **X** in the upper right corner

Also the compartment on the display will flash as well as the second sensor icon on the bottom line of the display.

The state of the permit output relay will be shown as a cross in the right upper corner of the display.

Explanation of used icons on the Display

For detailed information a display is added. OPW have chosen to use an organic display to make sure the display is visible when dark, consumes low power and is usable in cold environments. Icons are used to avoid a language's confusion. A list of the used icon is shown in









Table 4. Where possible In the right / bottom corner a four digit numerically code appears when an error is detected. In most cases a rear view of the socket is shown with corresponding icon and pin number. Since there are many possible messages it's impossible to use icons or text on a small display to present clear and unequivocal information. A rough subdivision is shown below in Table 3 the number before the icon is the number of the terminal and plug NOT the compartment number.

Due to the complexity and amount of possible faults contact OPW or your distributor for assistance when an error number appears.

Table 3

Symbol	Error range	Explanation (in combination with rear view of plug)
!	0000...0999	System error.
+	1000...1999	Short to ground (will show 10 next to icon)
-	2000...2999	Open channel (will be shown next to open pin)
X	3000...3999	Short between probes number (number indicates shorted with)
!	4000...4999	Faulty probes
!	5000...6999	Out of spec sensors

Table 4

	Description	Example e.g.
?	Unknown	
✓	Accepted or valid	
✗	Rejected or not valid	
	Overfill sensor	
x 	x-wire Overfill sensor	5  >> 5-wire Overfill sensor
	Maintenance	
	Unknown overfill Sensor	
	antenna	Wi-Fi connections established
	network	Monitor has been connected to a network
	ROM monitor detected	
TBD	Smart socket	
TBD	Secondary input	
TBD	Sd-card	No or faulty SD card detected
TBD	Earth (loop)	
TBD	Earth (bolt)	
iD	Tag detected	
TBD	High humidity in housing detected	Internal humidity is high might be caused by moisture ingress
TBD	High temperature in housing detected	Internal temperature is high will shorten life cycle

Faulty detected sensors.

LED indication when a sensor fault (or more) is (are) detected

Green indicators : all off

Red indicator : all correct detected sensors are flashing and faulty sensor(s) is (are) continuous on

If the fault is bypassed the rack monitor will revert to the state mentioned above with the faulty channels bypassed.

Note: in some cases most likely with Five-Wire sensors it is not possible to continue with overflow detection functionality.

Sensor detection.

The 88xxE Rack monitor is an auto switching rack monitor and will detect automatically the 2 types commonly used overflow sensors. Before the rack monitor switch to permissive the following steps will be performed.

1. Individual short detection between sensors and ground.
2. Resistive ground detection via pin 9
3. Ground bolt detection via pin 9
4. Sensor type detection
5. Detected sensors complies to EN13922
6. Detected sensors complies to Rest Of the World specifications (ROW)
7. Detected sensors appears to work but not complies to the above specifications.

Note: Overflow sensors commonly used in industry are not necessarily compatible with commonly used Rack Monitors in industry. The specification of the ROW overflow sensor are based on an extensive worldwide sensor collection. All parameters of those sensors are collected and the boundaries are stored in a table inside the 88xxE Rack monitor.

Note: The European Standard EN13922 describes the following points.

- Functions
- Major components
- Characteristics
- Test methods

Note: in some cases the rack monitor is still able to use the connected sensor as an overflow detection device. The operator will be asked to accept the detected sensor by using the Blue bypass key.

Step 1.

In this step the rack monitor is checking if all wires are connected to a sensor and there are no shorts between channels.

E.g. If on the tank truck one sensor is connected to two pins on the socket or one dummy channel is used to emulate two dry sensors the Rack monitor will detect this as a short and show this on the Oled-Display.

Step 2. & 3

Although ground verification is continues it is mention in this document as a step.

Since many Tank-Trucks are equipped with a ground bolt the 88xxE Rack Monitor will accept this automatically as a proper ground verification.

Be aware that conform the EN13922 in combination with Five-Wire sensor(s) the earth verification is connected in series with the vapour recovery hose interlock switch

Step 4.

The Rack monitor will apply power to the sensor and analyse the measured signal.

If no Two-Wire sensors are detected, power will be applied at channel 8 and a pulse will be transmitted at pin 4

If a return pulse is detected the rack monitor will continue with Five-Wire sensors.

Note: When the Rack Monitor is connected to already wet sensors it cannot determine the parameters of that sensor.

All measured data will be compared with the stored settings and dipswitch settings.

If the dipswitch is set to EN13922 the Rack Monitor will continue with step 5

If the dipswitch is set to ROW the Rack Monitor will continue with step 6

If the measure data not complies to the EN 13922 or ROW the rack monitor will continue with step 7

Step 5.

If all sensors complies to the EN13922 standard and if all sensors are dry and a proper ground is verified it will switch to permissive.

In case of Five-Wire sensor and channel 9 (pin 9) is still an open channel or in case of Two-Wire sensor and an open channel 8 (pin 8) it will wait till the vapour recovery coupler is connected.

If everything is connected but one (or more) of the sensor(s) is (are) not conform the EN13922 the rack monitor will go to NON-permissive and will indicate the error on the Oled-Display (88x0E).

Function key will be ignored since the rack monitor is set to comply EN13922 directive

Step 6.

If all (DRY) sensors are within ROW specifications and a proper ground is verified the rack monitor will go to permissive.

When the Dipswitch is set to 6 channels instead of 8 the rack monitor expect 6 dry channels on terminal pin 3 till 8. terminal pin 1 and 2 will be left floating. (this with any Two-Wire sensor).

Note: *if more than 6 Two-Wire sensors are detected when the 88xxE is set to 6 channels an error will be shown on the top bar of the OLED with the character '8'.*

This error can be bypassed to continue to loading

Step 7.

If the 88xxE Rack Monitor cannot determine the type and/or amount of sensors it will go directly to unknown sensors detected and a bypass key is needed to continue. (See bypass chapter for details)

Firmware upgrade.

The 88xxE Rack monitor is built for the future therefore new updates to expand the functionality of this rack monitor can be expected.

To upgrade your 88xxE rack monitor switch off all power to the rack monitor. Remove the lid (see installation manual for details) and if there is a memory card already placed at the lower right corner replace it with the new card. (see Figure 2)

Close the door (see installation manual for details) and restore power.

The rack monitor will copy the needed files from the card to its memory.

The 88x4E lower bar will flashing blue during programming and green during verifying the programmed software.

Both bars will red if an error occurs during programming. (Switching power off and on is needed).

With an 88x0E the channel LED's will act as a loading bar. Blue for programming, green for verifying Monitor will start the Led test If the programming is successfully ended. See chapter "power up / Led test".

Copying files from the card and installing will take approximate 2 minutes.

The new firmware will/can be supplied with a new appendix. Please save this appendix with this manual.

The rack monitor is ready for use if the screens are flashing in the normal pattern.

Event log.

If the 88xxE rack monitor is provided with a SD-card, all events are stored (time stamped)

The 88xxE Rack monitor has his own Real Time Clock, factory set to Greenwich Mean Time (GMT)

Note: GMT does not change with daylight savings time!

Communication settings.

Any 88xxE monitor can be built with and RS422/485 data communication port.

Ask OPW for available type communication ports.

Data communication.

The 88xxE Rack Monitor can be set to emulate the 8500E /8800E data communication

In this way the 88xxE is downwards compatible with the 8500E Rack Monitor.

To select this 8500E data communication set S2 in the on position.

Every second a string will be send to e.g. the remote display.

At this moment no other protocols are supported.

Ask OPW Fluid transfer Group for latest development.

Civacon 8500/8800 Protocol

Message Format:

STX	A1A2*	Command Text	ETX	LRC
-----	-------	--------------	-----	-----

Where:

STX = Start of Text = 02 Hex
A1A2 = Address = 01-99 Hex

Command Text = Character string including Command Code and associated parameters

ETX = End of Text = 03 Hex
LRC = Longitudinal Redundancy Check

An underscore _ (5Fh) is used as a command Text delimiter

The LRC is a 7 bit ASCII character computed as the Exclusive OR sum of all characters following the STX and including the ETX characters.

Currently the following commands are defined

OS Overfill Status
VR Vehicle Recognition data
KD Bypass key Data

Currently the following commands are implemented

OS Overfill Status
VR Vehicle Recognition data

Command Code OS – Overfill Status

Request Command: $S_{T_X}AA OS_{E_X}LRC.$
 Reply Message: $S_{T_X}AA OS_{C1}C2C3C4C5_{E_X}LRC$ Where C1-
 C5 are defined in Tables 4~7.

Where X indicates an asserted condition.

Table 4

Character 'C1' Definition

Character	Hex Value	Sensor Permit	Ground Verified	Ground Loop	Ground Bolt
0	30				
5	35		X		X
6	36		X	X	
8	38	X			
>	3E	X	X	X	
=	3D	X	X		X

Table 5

Character 'C2' Definition

Character	Hex Value	2 Wire Sensors	5 Wire Sensors	5 Wire Permit
0	30			
2	32		X	
3	33		X	X
8	38	X		

Table 6

Character 'C3 & C4' Definition

Character	Hex Value	Sensor 4	Sensor 3	Sensor 2	Sensor 1	C3
	Value	Sensor 8	Sensor 7	Sensor 6	Sensor 5	C4
0	30					
1	31				X	
2	32			X		
3	33			X	X	
4	34		X			
5	35		X		X	
6	36		X	X		
7	37		X	X	X	
8	38	X				
9	39	X			X	
:	3A	X		X		
;	3B	X		X	X	
<	3C	X	X			
=	3D	X	X		X	
>	3E	X	X	X		
?	3F	X	X	X	X	

Table 7

Character 'C5' Definition

Character	Hex Value	Sensor 12	Sensor 11	Sensor 10	Sensor 9
0	30				
1	31				X
2	32			X	
4	34		X		
8	38	X			

Command Code

Request Command: $S_{TX} AA VR_{TX} E_{TX} LRC.$

Reply Message: $S_{TX} AA VR_C1F1 E_{TX} LRC$

Where

C1 = 0 (30 Hex) = No Vehicle Recognition System Detected

C1 = 1 (31 Hex) = Vehicle Recognition System Detected

F1 = 8 character serial number

1-Byte CRC Code	6 -Byte Serial code	1-Byte Family code
-----------------	---------------------	--------------------

Modbus.

Two register tables are available due compatibility with previous systems.
Below the old and brief defined register table.

This information will be available in register 20A to 21A.
Serial communication is available via the RS485 port with a pre-settable baud-rate see
Figure 2.

Reg.	Name	Dir	Storage	Description
20A-20C	Truck Serial Number	R	Dynamic	48-Bit Truck ID/serial number
20D-214	Sensor State Bytes	R	Dynamic	Individual tank/sensor state (one byte per sensor/channel)
21A	Truck Status	R	Dynamic	Flags indicating Truck status

The Vehicle Serial Number registers contain the currently-connected truck's "serial number", if any. A value of 0x00 means there is no readable serial truck number, a value of 0xFFFFFFFF means the serial number hasn't been determined yet.

The layout of the truck's serial number in the three Truck Serial Number registers is:

Vehicle Id. Register 20A~20C					
MSB	LSB	MSB	LSB	MSB	LSB
Register 20A		Register 20B		Register 20C	
S/N MSB		Vehicle ID		S/N LSB	

The truck status register contains relevant data of the connected Truck.

Truck Status Register 21A

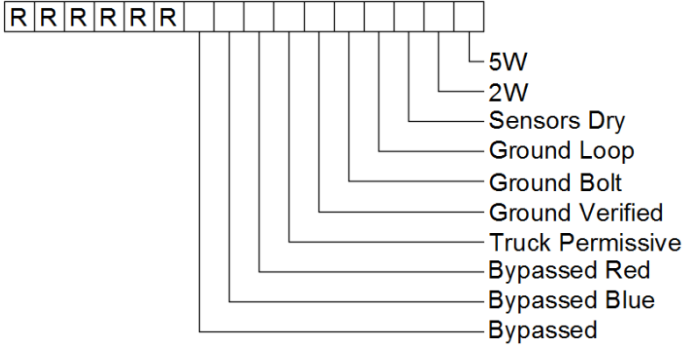

MSB	LSB	MSB	LSB	MSB	LSB	MSB	LSB	MSB	LSB	MSB	LSB	MSB	LSB	MSB	LSB
Register 20D		Register 20E		Register 20F		Register 210		Register 211		Register 212		Register 213		Register 214	
Sensor 1 State	Sensor 2 State	Sensor 3 State	Sensor 4 State	Sensor 5 State	Sensor 6 State	Sensor 7 State	Sensor 8 State	Sensor 9 State	Sensor 10 State	Sensor 11 State	Sensor 12 State	Sensor 13 State	Sensor 14 State	Sensor 15 State	Sensor 16 State

Sensor Status Register 20D ~ 214		
State	Value	Description
Unknown	0	Initial State
Wet	1	Wet Sensor
Dry	2	Dry Sensor

Current Modbus 88xx

Physical interface

See **Fout! Verwijzingsbron niet gevonden.** Figure 2 for detailed dipswitch settings

Registers

Table 5 shows all Modbus registers.

Registers that aren't straight forward will be described in further detail later in this document.

Reg. start	Reg. End	Name	Dir	Description
0	15	Rack serial	R	Serial number of the Rack
16	16	Application version	R	The version of the application
17	17	Hardware version	R	The version of the hardware
18	18	Bootloader version	R	The version of the bootloader
19	33	Reset counts	R	Number of times rack was reset
34	34	Dipswitch	R	Selected bits on the dipswitch
35	38	Truck serial	R	48-bit truck ID/serial number
39	70	Reserved	R	Reserved, always reads as 0
71	78	Probe status	R	Individual probe status
79	79	Rack status	R	Flags indicating Truck status
80	83	Channel Status	R	Individual channel status
84	84	Compartment count	R	Number of compartments detected
85	85	System error	R	Active system error
86	86	Vehicle error	R	Active error from the truck status
88	89	Date and time	R/W	Date and time stored by the Rack

Table 5 Modbus registers

Rack serial

The serial of the rack monitor is stored is a null terminated string in registers 0-15. Register 0 contains the first character in the most significant byte of the register and the second character in the least significant byte of the register. The third and fourth character are stored in the most and least significant byte of register 1 respectively.

Register 0		Register 1		Register 2		...	Register 15	
MSB	LSB	MSB	LSB	MSB	LSB	...	MSB	LSB
Char 1	Char 2	Char 3	Char 4	Char 5	Char 6	...	Char 31	Char 32

Table 6 Rack serial

Reset counts

The reset counts keep track of the last reason why the Rack resets and the number of times the rack resets for each reason. Everything is stored as an unsigned 16-bit value.

Register	Reset reason
19	Last reset reason for reset
20	Trap error
21	Illegal opcode
22	Configuration mismatch
23	External reset
24	Reset instruction
25	Watchdog
26	brownout
27	Oscillator fail
28	Address error
29	Hard trap error
30	Stack error
31	Math error
32	Dma error
33	Soft trap error

Table 7 Reset counts

Vehicle Id

The vehicle ID is stored in 4 registers giving a total of 64 bits or 8 bytes. The first byte is the tag crc, register 35 through 37 are the 48-bit unique serial. Register 38 shows the family code and crc of the device. When the Rack is still searching for a tag, or when there is no valid ground verification, all registers will contain the value 0xFFFF. When there is no valid tag found all registers will contain the value 0x0000.

Register 35		Register 36		Register 37		Register 38	
MSB	LSB	MSB	LSB	MSB	LSB	MSB	LSB
serial	Serial	Family	Crc
MSB					LSB	code	

Table 8 Vehicle ID

Probe status

The probe status is given for any for each probe in the probe status registers.

Register 71		Register 72		...	Register 78	
MSB	LSB	MSB	LSB	...	MSB	LSB
Probe 1 State	Probe 2 State	Probe 3 State	Probe 4 State	...	Probe 15 State	Probe 16 State

Table 9 Probe status registers

State	Value	Description
Initial/Unknown	0	Initial value, probe status can't be determined
Non permissive	1	No permissive signal from probe
permissive	2	Probe is permissive
Non permissive latched	3	Probe was non-permissive, but is now permissive
Out of spec	4	Probe doesn't follow specification
Open	5	Probe channel open (2-wire only)
Short to ground	6	Probe channel shorted (2-wire only)
Short to other channel	7	Probe channel shorted to different channel (2-wire only)
Bypassed non-permissive	8	Probe is bypassed and currently non-permissive
Bypassed permissive	9	Probe is bypassed and currently permissive

Table 10 Probe states

Rack status

The rack status register has several status flags. Flag 0 is bit 0 of the register

Flag	Meaning
Flag 0	5-wire detected
Flag 1	2-wire detected
Flag 2	Sensors are permissive
Flag 3	Ground loop detected
Flag 4	Ground bolt detected
Flag 5	Ground verified
Flag 6	Rack permissive
Flag 7	Red function key detected
Flag 8	Blue function key detected
Flag 9	Rack is in bypass
Flag 10	Probes are bypassed
Flag 11	Ground verification is bypassed
Flag 12	Ground restored status is active
Flag 13	Over-temperature detected inside housing
Flag 14	High humidity detected inside housing
Flag 15	Reserved

Table 11 Rack status

Channel status

The status of channels 1..8 is given in the channel status registers.

Register 80		Register 81		Register 82		Register 83	
MSB	LSB	MSB	LSB	MSB	LSB	MSB	LSB
Channel 1 Status	Channel 2 Status	Channel 3 Status	Channel 4 Status	Channel 5 Status	Channel 6 Status	Channel 7 Status	Channel 8 Status

Table 12 Channel status registers

State	Value	Description
Initial	0	Initial value
Channel good	1	Channel is good
Short to ground	2	Channel is shorted to ground
Open	3	Channel is open
Short to other channel	4	Channel shorted to another channel
Channel overloaded	5	Channel is overloaded

Table 13 Channel states

Date and time

The datetime is stored in register 84..85 as an unsigned 32-bit value in UNIX format. Reference EPOCH (a moment which system time is usually measured) is 1-Jan-1970 00:00:00

Register 87	Register 88
Least significant word	Most significant word

SIL rating.

The minimum Sil rating of the 88xx according IEC61508 is SIL1 which means a minimum risk reduction factor of 100.000-1.000.000 per hour at continuous operation

The 88xx can be equipped with a secondary detection circuit with its own relay output to get a higher Sil rating.

This circuit is, besides power-supply, completely independent of the main circuitry.

The extra relay output but can be wired separately to the terminal safety automation system to create a the higher probability of dangerous failure per hour.

Ask OPW for detailed information.

Supplied accessories.

A blue IR key is supplied to bypass the rack monitor, except for open and shorted channels

A special (RED) IR key to bypass open and shorted channels.

Installation and Operation manual.

Optional system accessories.

7300-7300 conductor	Green plug (4 J-slot) and 10-conductor orange coiled cable, w/ #9 screened
7100-7100 conductor	Blue plug (3 J-slot) and 10-conductor orange coiled cable, w/ #9 screened
7400E conductor	Black plug (4 J-slot) and 10-conductor blue coiled cable, w/ #9 screened
7450E	Passive storage hanger.
75x0E	Series junction box.
753xE	Junction box with emergency switch. (contact OPW ENGINEERED SYSTEMS for availability).

Maintenance.

When servicing the Rack Monitor 88xxE the following needs attention:

- Before maintenance the full installation must be shut down/off before proceeding.
- Maintenance must be performed by authorized personnel only.
- All fasteners must be inspected periodically.
- After maintenance is performed, the Rack Monitor 88xxE must be tested before the next use.
- Periodical inspection (every 6 months) for leakages (especially with heavy rainfall or wind).
- Periodically maintenance is not required, but we recommend to check the internals at least once a year, by tucking all the cables and inspect for any corrosion.
- Depending upon the condition of the inside the enclosure after inspection, it may be necessary to apply a coating of corrosion inhibiting spray to the interior components.
- During servicing loading and unloading of tank trucks is not allowed.
- During maintenance (partial) disassembling could be necessary, the same risks and procedures apply as during installation.

Check Points.

During maintenance the following items should be checked:

- All earth cables should rigidly connected and free from corrosion,
- If there is no moisture inside of the enclosure,
- If the main seal is still intact and still soft and smooth,
- If there is no corrosion on any part inside the enclosure,
- Visual inspect all electronic components, with special attention for the voltage suppressors (also see trouble shooting in Troubleshooting).

Caution: When replacing the fuses, always make sure that you replace the fuse with original ones with an equal stated value.

When maintenance has been performed, the following should be done before closing the Rack Monitor 88xxE

- Replace the corrosion protector (should be done every 6 months),
- Put grease on the main seal,
- Make sure that all earth cables are connected,
- Apply coating (if necessary) to the interior components,

Caution: - Make sure, before closing the enclosure, that the cables do not get stuck between the door and the bottom side of the enclosure.
- When tightening the bolts, apply the torque mentioned in the installation manual.

Troubleshooting.

The following troubleshooting guide will give you first aid hands-on in solving most of the problems you can encounter.

there are two types of problems.

1. operational issues.
2. hardware problems.

Most commonly are the operational issues. Caused before or during loading a Tank-Truck.

The amount of hardware problems will increase if the 88xxE Rack Monitor is NOT serviced on a regular base. Especially the cable and plug are subject to wear out. Although a high quality cable is used it cannot withstand the strength of a Tank-Truck. Also dirt can build up between the spring-loaded pins and the insert of the plug. If pin 10 is not moving in the insert of the plug an electrostatic discharge via other pin can damage the input circuits of the 88xxE Rack Monitor. Therefore check cable and pins/plug on a regular base to avoid traffic block on a loading bay.

The common operational issues are wrong, defect or poor connected sensors. In some cases a not correct adjusted sensor can cause a premature (or delayed) shutoff of the loading procedure.

If the 88xxE Rack Monitor does switch to the permissive state it will show the most probably cause on the OLED Display

The 88xxE findings are based on the measured data and its conclusion might not be the correct conclusion.

If the 88xxE Rack Monitor is set to accept only EN13922 compliant sensors, it will reject ALL sensors and wiring which is not according this standard. This will be shown on the Oled-Display. Since this is a relative new directive a lot of Tank-Trucks might not be wired according this directive or the sensors are on the boundary of the EN13922. During this transition period the 88xxE Rack Monitor can be set to ROW (Rest Of the World) values by means of placing the switch 1 and 2 of the lower switches to off

e.g. previous On Board Monitors (OBM or ROM) can be connected with shorted channels and since the EN13922 will refuse shorts it will NOT go to the permissive state.

Note: Faulted channels, for instance "Open Wire" cannot be bypassed with the Blue Bypass key. The Red Bypass key must be used

Condition	Possible Cause	Solution
- The Rack Monitor 88xxE doesn't turn ON	- The mains isn't connected.	- Connect the mains.
		- Check if the main wiring is connected according to the installation instruction.
		- Check if there is any power available at the terminal of the Rack Monitor 88xxE.
	- The fuses are broken.	- Replace the fuses for new ones.
		Note: the fuses might have been blown due to the high inrush current of the power-supply.
		Always use same rated fuses.
- System goes directly into 'NON PERMISSIVE'	- The dead man switch is not connected.	- Connect the cable according to the installation manual.
		- Connect a bypass wire between pin 1 & 2 according to the installation manual.
- System does not indicate correct amount of compartments in 5-Wire mode	- bad connections in sensor housing and/or plug/socket.	- Check green and white wires - Clean pin 5 and 10 on plug and socket

For all other possible inflictions/damages to the Rack Monitor 8800E/8801E, contact **OPW Engineered Systems** and ask for assistance to obtain a safe and right use.

Annex A – Additional Electrical Drawings

Ask OPW for different connection diagrams e.g. dual socket or junction box

Annex B – Set clock

The internal real time clock has been calibrated to the highest possible accuracy during production and set to GMT.

This clock is mainly used for time stamping the event logging to the SD-Card.

End user might want to set the clock to the local region setting and this can be done in different way's.

- Via a file on the SD-Card.
File name "TIME.TXT" format YYYYMMDDHHMMSS.
The time YYYYMMDDHHMMSS will be used to set the clock, "TIME.TXT" will be deleted after reading.
Step 1, power-down monitor.
Step 2, insert SD-Card with file "TIME.TXT" with content YYYYMMDDHHMMSS.
Step 3, power-up monitor.
Note: it will take aprox. 1second to modify the clock after power-up
- Via data communication MODBUS register 88 & 89 see above.

Annex C - Recommended Spare Parts

With the purchase of the Rack Monitor the **OPW Engineered Systems** recommends some spare parts to be purchased. Although this Rack Monitor 88xxE is designed with solid state lamps and a minimum maintenance spare parts are available. When parts are replaced, it is recommended to replace them with the original parts.

When using the Rack Monitor 88xxE for its intended use and the normal environments these spare parts will be useful at the end of the lifecycle of the given parts, but they have been known to be necessary to resume working swiftly after replacing these parts.

The recommended spare parts are:

Part number	Description	Quantity
H71197	Main Seal	1
H71307	Corrosion Protector VCI-101/ACF-50	1
EL04208	Mains power input fuse (TR5 1A Slow Blow 250V), Qty. 2 per unit)	1
EL04141	Relay contact output fuse (TR5 2A Slow Blow 250V), Qty. 3 per unit)	1

The following parts are also available:

Part number	Description	Quantity
EL00203-CRK	Internally used connector kit	1
BCU-BLUE	Blue Function key (low level)	1
BCU-RED	Red Function key (high level)	1
EL06802	SD-Ram Card	1
8800-BRK-14	Fastener kit 14x Door Bolts	1
H71342	Installation manual	1
EL05104	Cable gland M20x1,5 Ø cable diameter 10-14mm ATEX-Ex/d (not armed)	1
EL05134	Cable gland M20x1,5 Ø cable diameter 3.1-8.6mm ATEX-Ex/d (not armed)	1
73xx Series	Green (2-Wire / Therm.) Plug and 8 or 10-conductor straight or coiled cable.	1
71xx Series	Blue (5-Wire Optic Plug and 6 or 10-conductor straight or coiled cable.	1
7400E	Black Plug and 10-conductor with screened #9 data conductor coiled cable (per EN13922).	1

Annex C – Certificates

- NEN-EN-ISO 9001:2000 Certificate.
- Quality certificate.
- ATEX certificate.
- IECEx certificate
- QPS certificate

Contact OPW fluid transfer if insert is missing in Operation or Installation manual.