

THE LOOP SYSTEM™ ORDERING GUIDE



OPW 
RETAIL FUELING
a **DOVER** company

OPWRetailFueling.com

Loop
SYSTEM

FUELED BY
EXCELLENCE

The Loop System contains fewer parts to stock and install



ABOVEGROUND MAINTENANCE, ABOVE & BEYOND PERFORMANCE



**ELECTROTITE
TANK SUMPS**



**DUAL-LAYER
ACCESS PIPES**

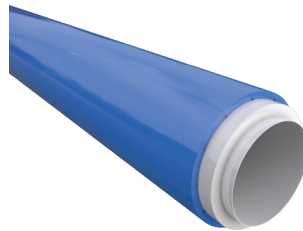

**UL 971-LISTED
COAXIAL PIPES**



**DUAL-SIDED RIGID
ENTRY FITTINGS**

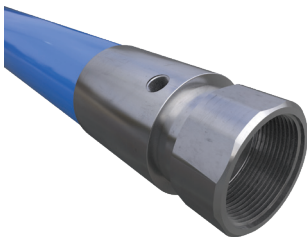

**DOUBLE-WALL PIPE
COUPLINGS (DPC)**



**10 PLUS
EMERGENCY
VALVES**



**PRE-FABRICATED
QUICK-COUPLE
DISPENSER SUMPS**



**HIFLO DISPENSER
SUMPS**

The Loop System™ Ordering Guide



Loop System Dispenser Sumps are shipped complete with factory-installed pipe entry fittings, OPW 10 Plus Shear Valves, and Stabilizer Bars. Each Dispenser Sump has been assigned a custom Sump Configuration Number based on the number and position of pipe entries into the sump. Each Sump Product Number reflects this configuration number as well as materials used and for the application needed. The guide below explains the Product Number in detail.

Benefits

- 50% Faster Installation Times
- 100% Accessible No Breaking Concrete
- Double Containment Protection
- Completely Testable
- End-to-End Monitoring
- Fewer Parts to Stock and Install



For high-flow applications, see HiFlo Ordering Guide on page 8.

Ordering Guide

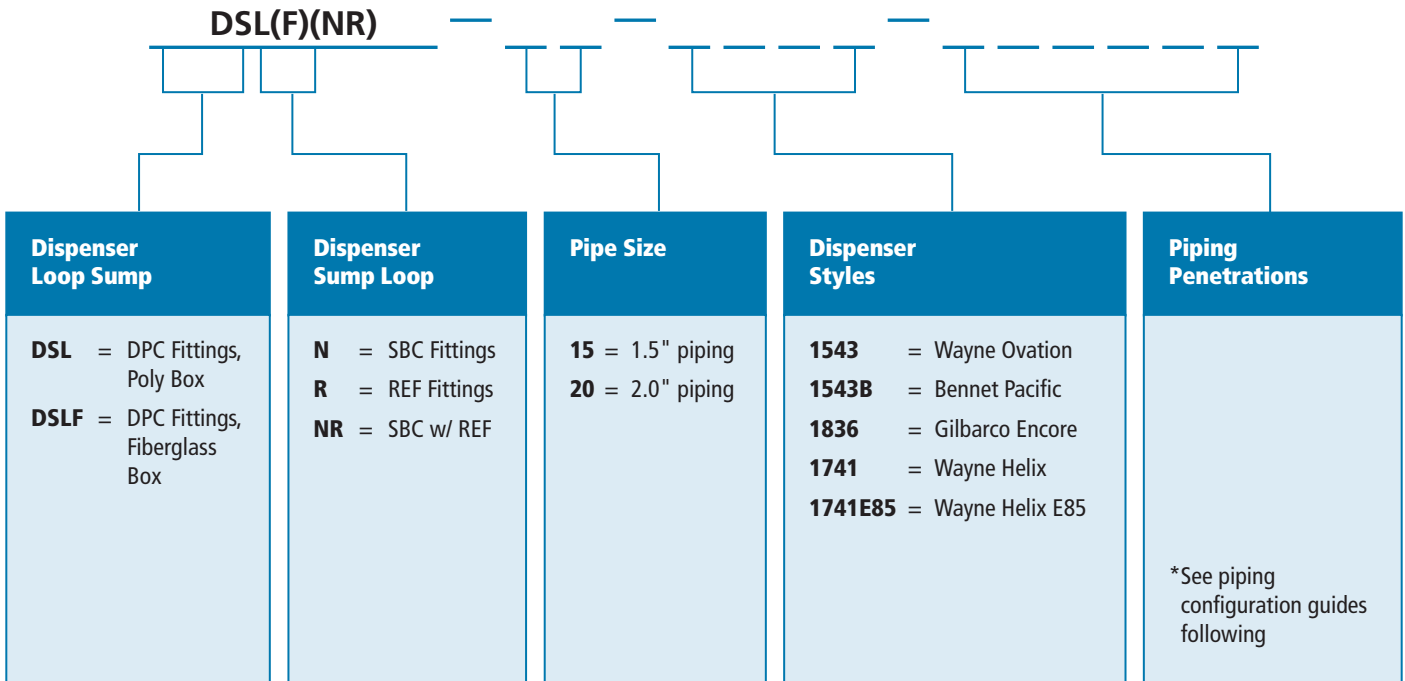

Forecourt Examples

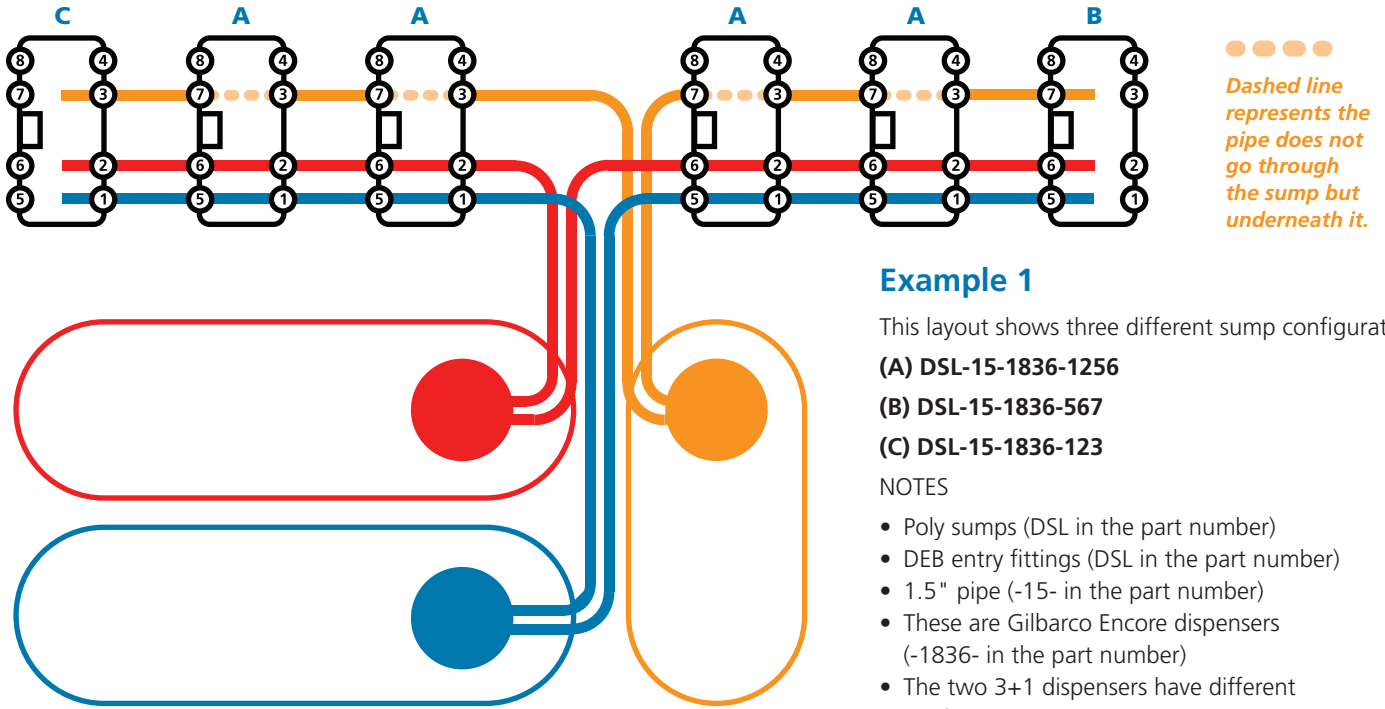

CONTACT CUSTOMER SERVICE FOR CUSTOM CONFIGURATIONS

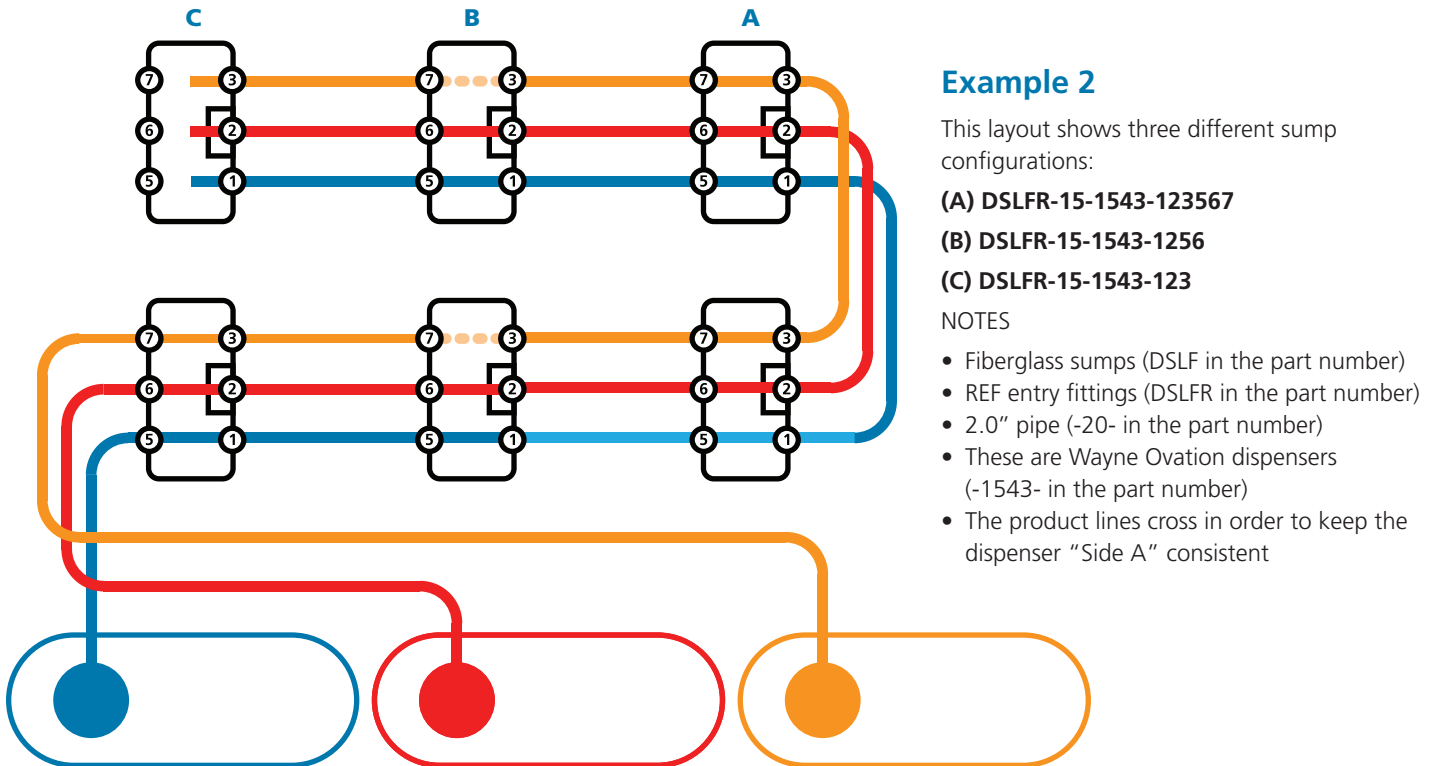

CONTACT CUSTOMER SERVICE FOR CUSTOM CONFIGURATIONS

The Loop System™ Ordering Guide



Gilbarco Encore

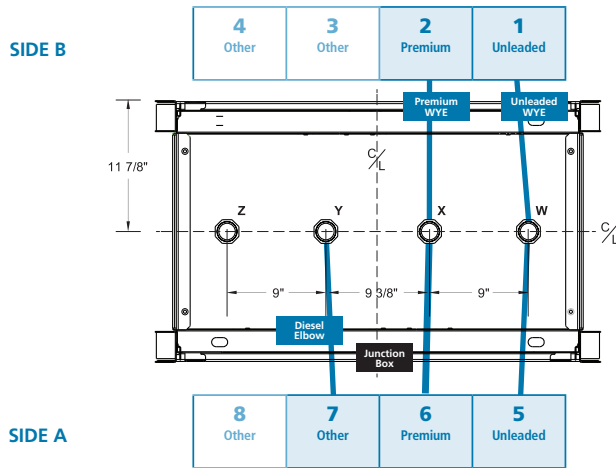

Wayne Ovation

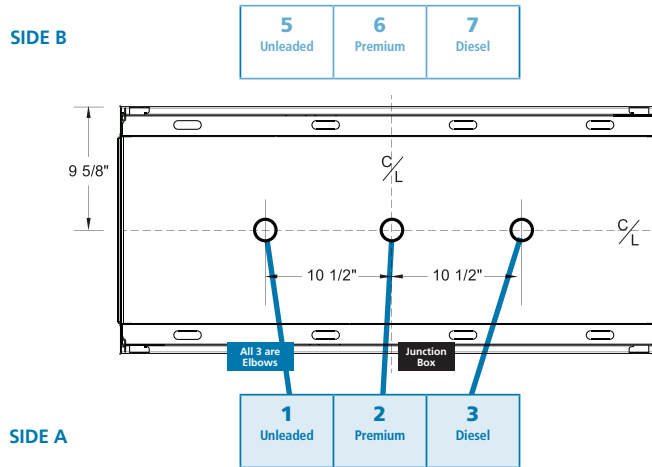

Wayne Four Product

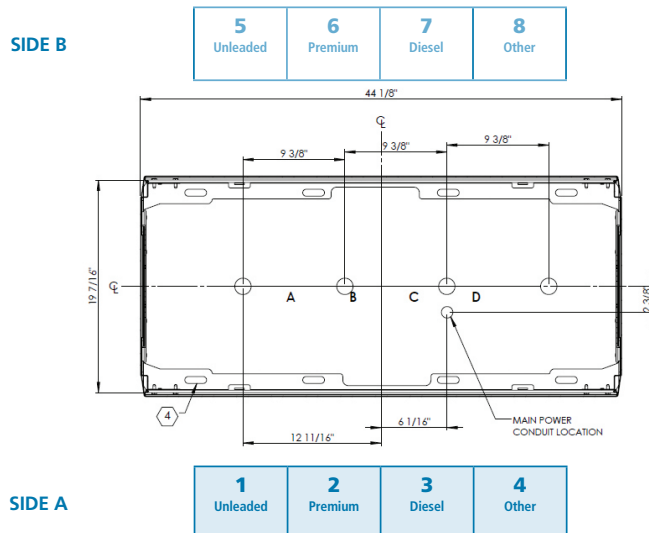

The Loop System™ Ordering Guide

Wayne Helix

SIDE B

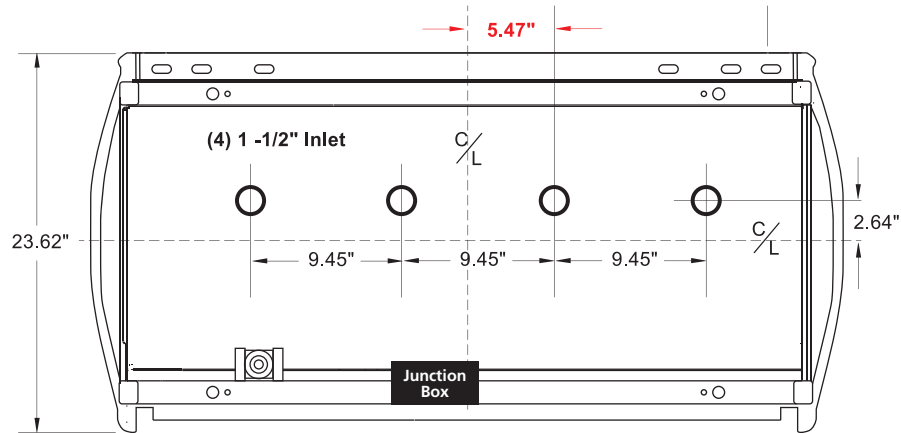

SIDE A



Wayne Helix E85

SIDE B

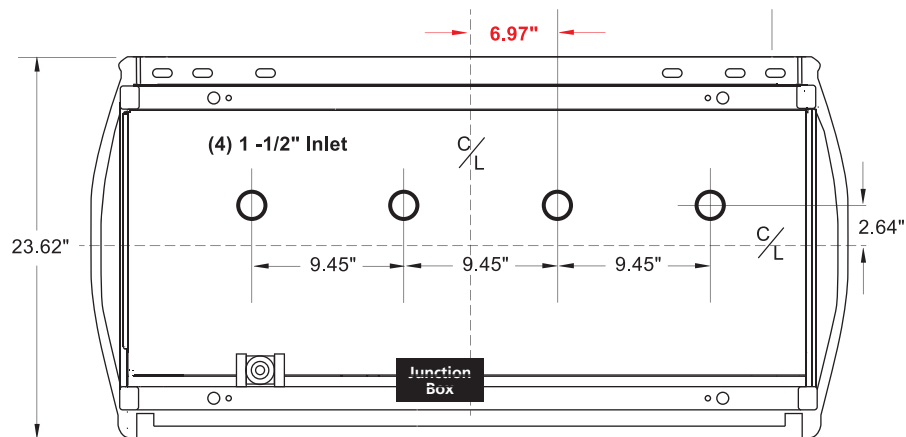

SIDE A



The Loop System™ Ordering Guide



The patented OPW HiFlo Loop System™ represents the state of the art in Retail Fueling containment technology offering a completely integrated, environmentally secure underground fuel-delivery system. By design, the system employs pre-fabricated and factory-assembled components resulting in dramatically less field labor, lower associated costs, and reduced potential for installation errors. The installed product preserves complete underground access to all piping connections, piping runs, and containment sumps. This unprecedented level of access allows for hassle-free inspections and maintenance without ever having to disrupt the business of the site with excavation. The HiFlo Loop System incorporates field-proven OPW technology to provide the same peace-of-mind that customers have come to expect from the traditional Retail Loop System.



Benefits

- **Compatible with Ovation and Encore High-Speed Dispensers**
- **Configurable for any Master->Satellite setup**
- **New 2" 10 Plus provides best-in-class flow and protection**
- **New Hybrid Entry Fitting (HEF) combines the benefits of REF outside the sump with the flexibility of DEB on the inner sump**
- **The OPW HiFlo Loop System™** – Providing a radically new solution to minimize traditional fuel-delivery system problems.
- **The End Result** – An exponentially higher level of environmental protection and lower cost of fuel-delivery system ownership.

Ordering Guide

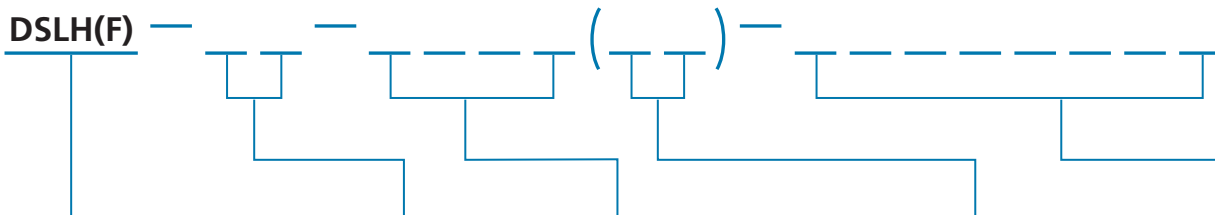

Dispenser Sump Loop, HiFlo	Trunk Line Size	Dispenser Style	Ovation Options (As Needed)	Configuration Layout
DSLH = Poly, DPC Fittings DSLHF = Fiberglass, DPC Fittings DSLHN* = Poly, SBC Fittings DSLHFN* = Fiberglass, SBC Fittings *Only available for 2" trunk lines	20 = 2" Trunk 30 = 3" Trunk 23 = 2" x 3" Trunk* 32 = 3" x 2" Trunk* XX = No Trunk, Satellite Dispenser *First number indicates Side A, Second number indicates Side B	1535L = Ovation HS, DEF Left 1535R = Ovation HS, DEF Right 1543 = Ovation HS 1836 = Gilbarco Encore 1836M = Gilbarco Encore Master	D = Dual Master T = With Strainer	See footprint charts

The HiFlo Loop System™ Ordering Guide

Encore Ultra-High Master (1836M)

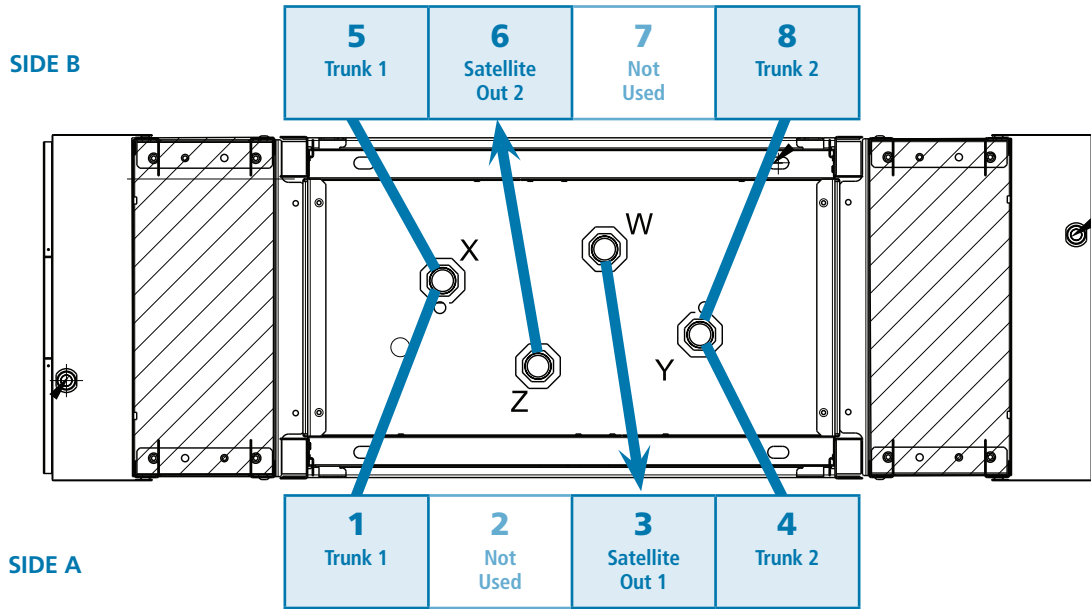

Encore Ultra-High, Single-Sided Master (1836M)

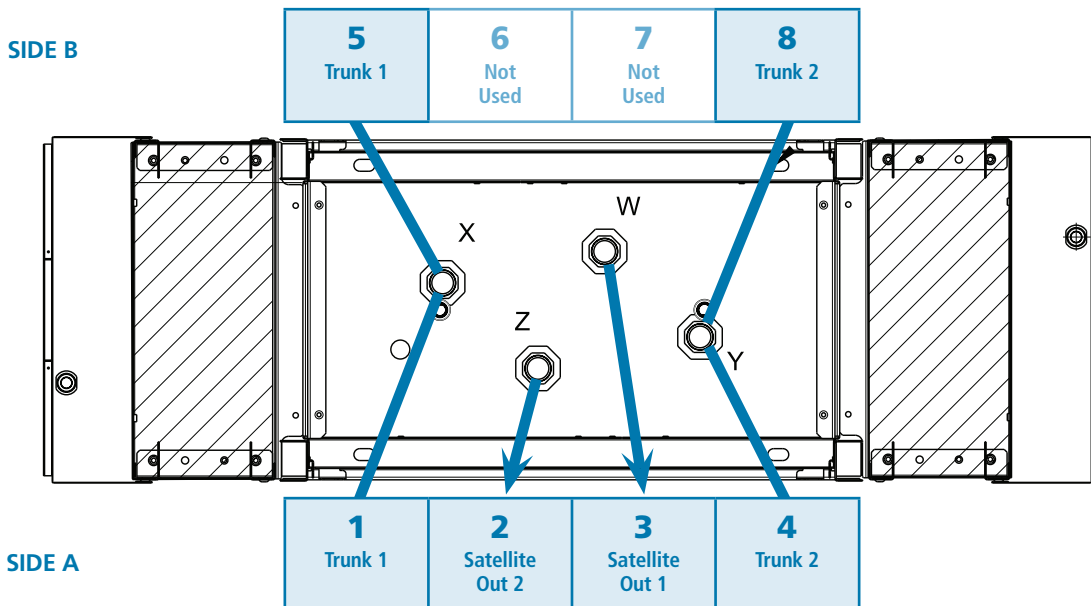

The HiFlo Loop System™ Ordering Guide



Encore Ultra-High Master/Satellite

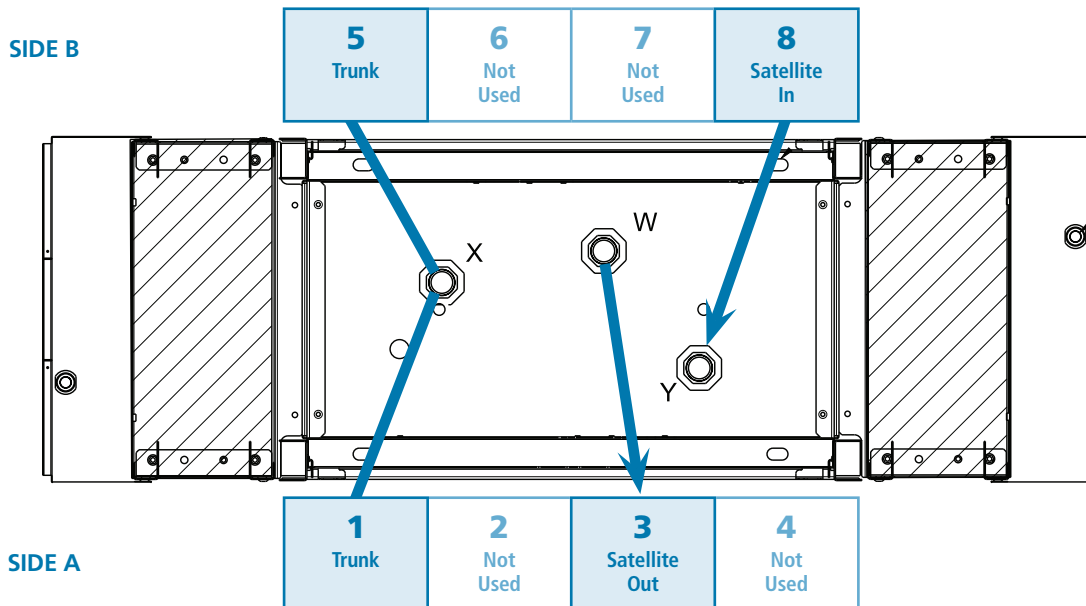

Encore Ultra-High Satellite

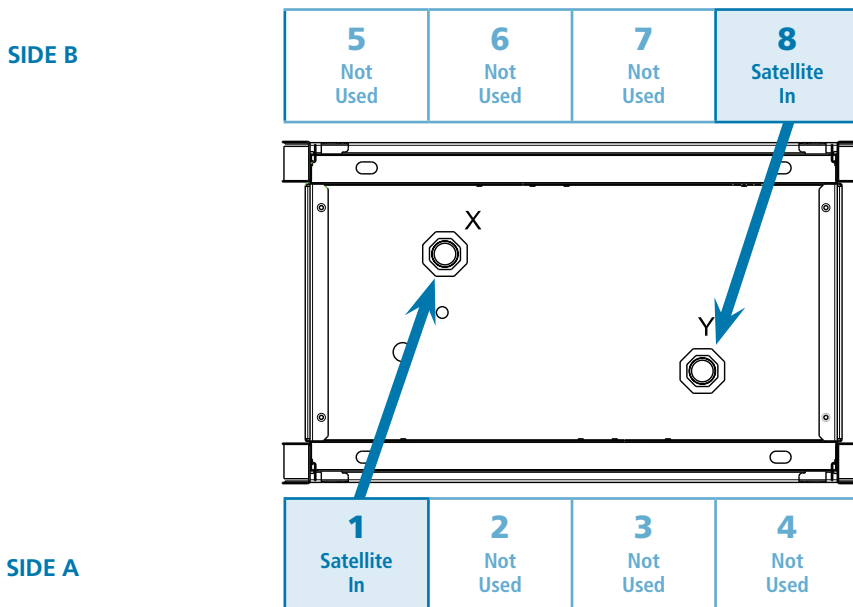

Note: For single-sided satellites, use position "1" on Side A.

The HiFlo Loop System™ Ordering Guide

Wayne Ovation HS, Single Master

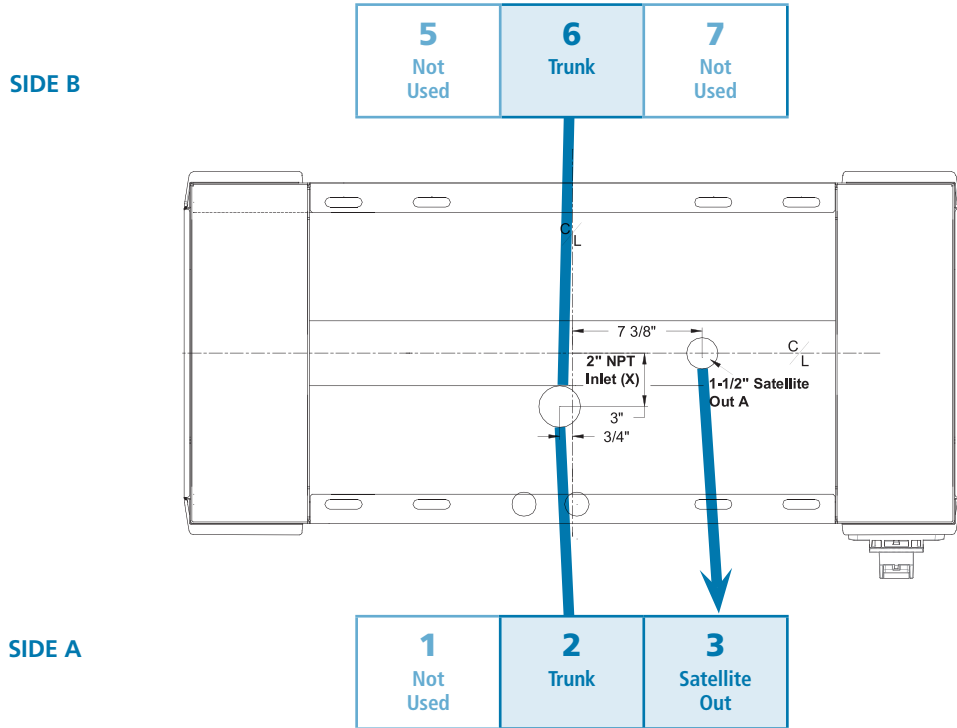

Wayne Ovation HS, Dual-Sided, Master

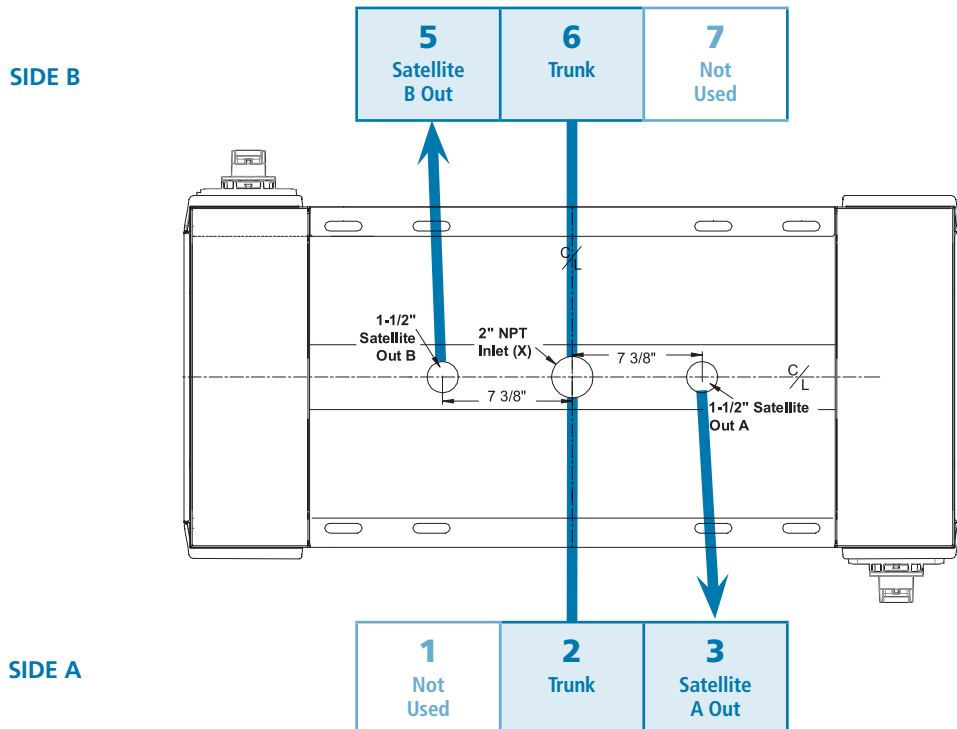

The HiFlo Loop System™ Ordering Guide



Wayne Ovation HS, Master/Satellite

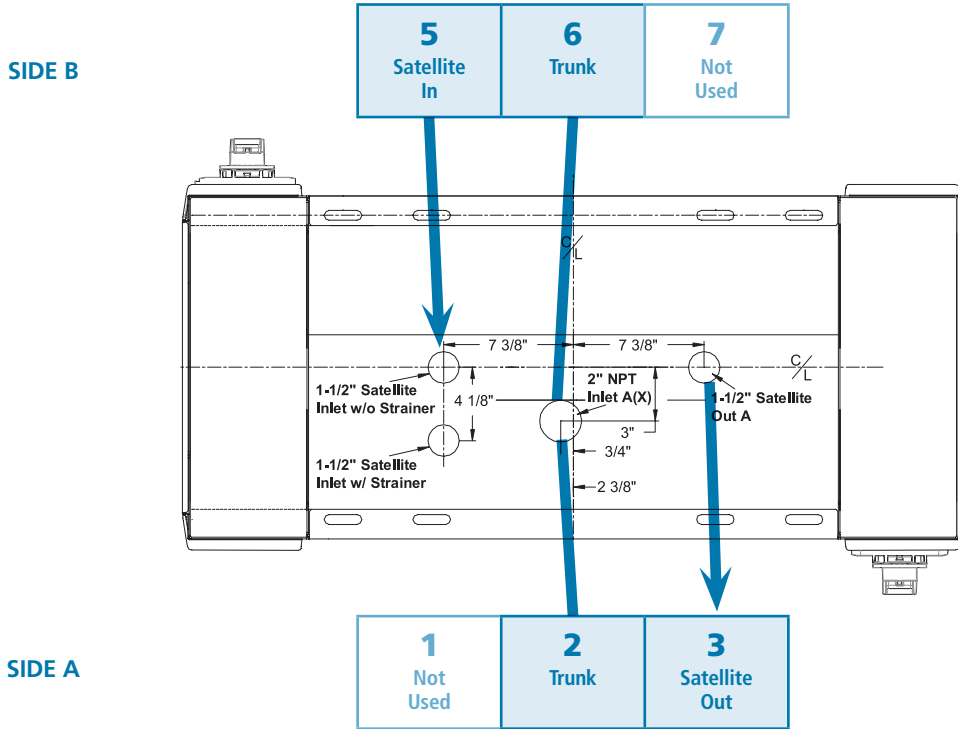

Wayne Ovation HS, Satellite

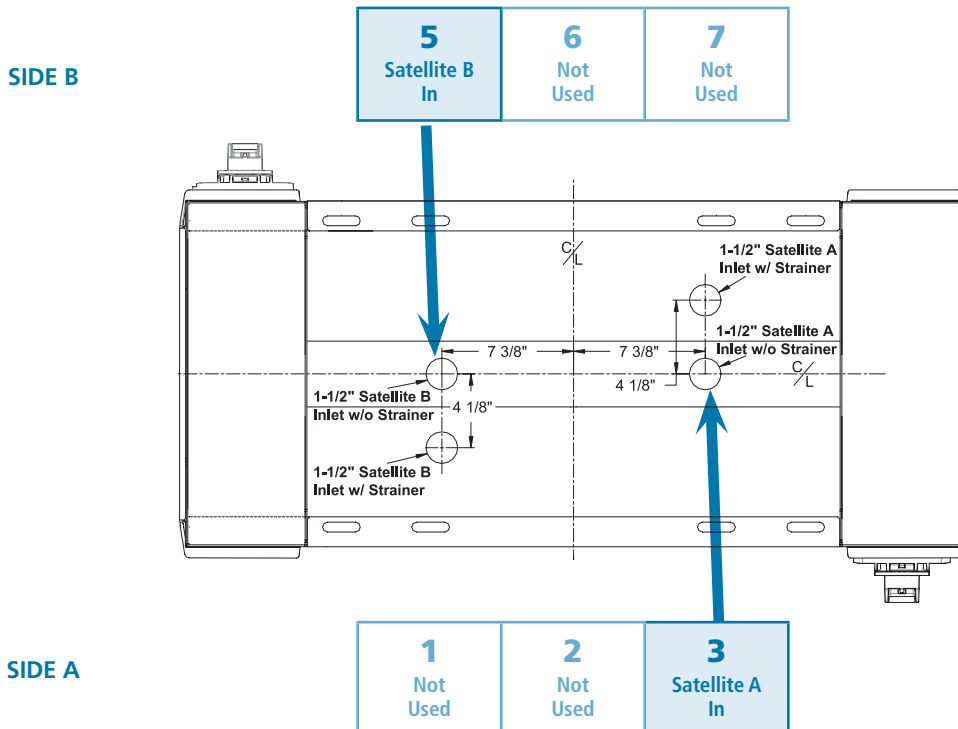

Note: For single-sided satellites, use position "3" on Side A.

The HiFlo Loop System™ Ordering Guide

Ovation HS Master Options

DSLH-30-1543-26

SIDE B

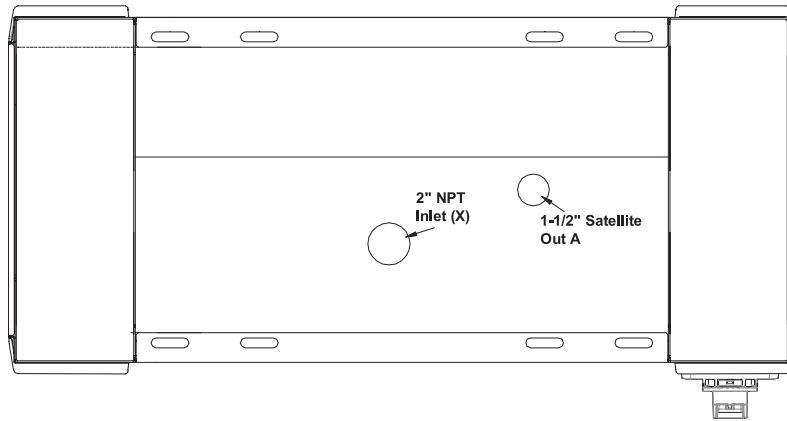

SIDE A

DSLH-30-1543D-26

SIDE B

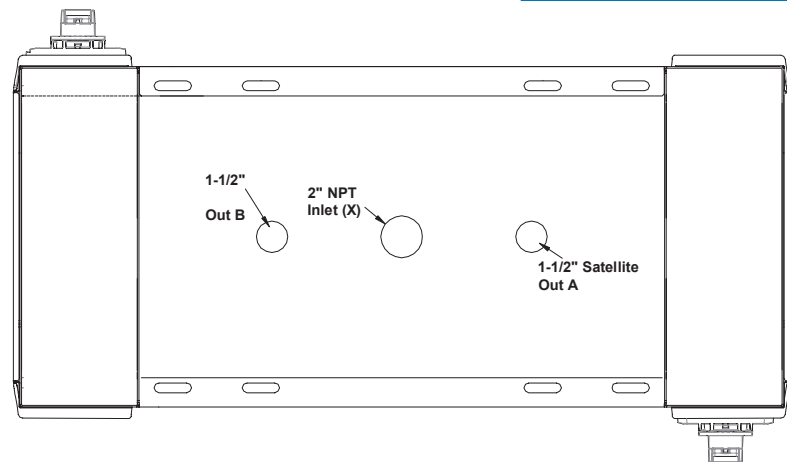

SIDE A

Double-Sided Master adds "D" for "DUAL"
(Only on Wayne)

The HiFlo Loop System™ Ordering Guide



Ovation HS DEF Options

DSLH-30-1543-26

Non-DEF uses
1543 Sump

SIDE B

SIDE A

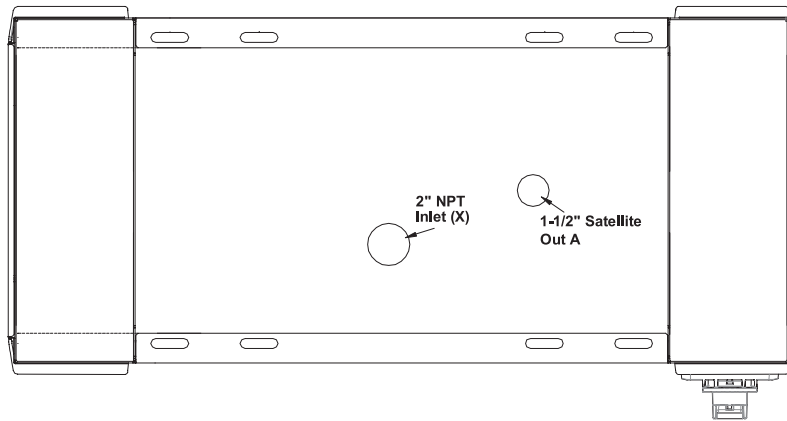

DSLH-30-1535L-26

Cold-Weather
DEF-combo
(heated cabinet)
dispensers use
1535 sump
(Only on Wayne)

SIDE B

SIDE A

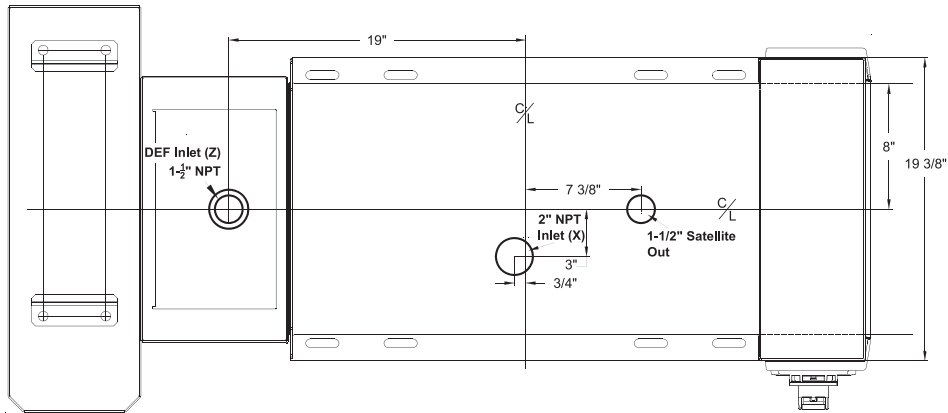

The HiFlo Loop System™ Ordering Guide

Ovation DEF Cabinet Options

DSLH-30-1535LD-26

DEF side specified with "L" for "Left"
(Only on Wayne)

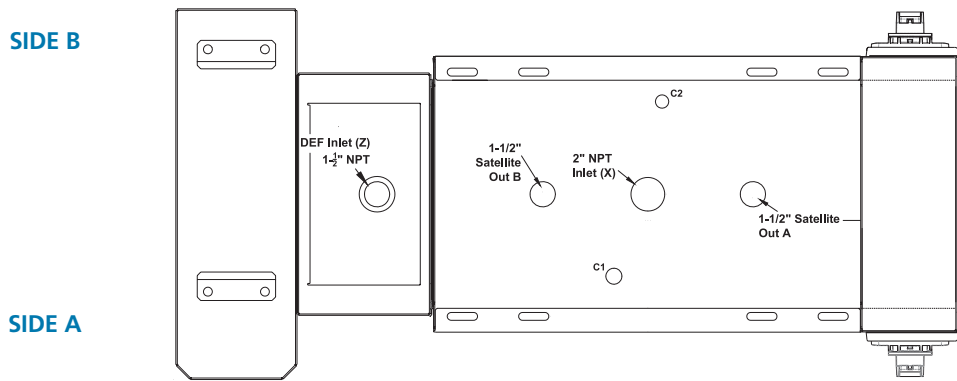

DSLH-30-1535RD-26

DEF side specified with "R" for "Right"
(Only on Wayne)

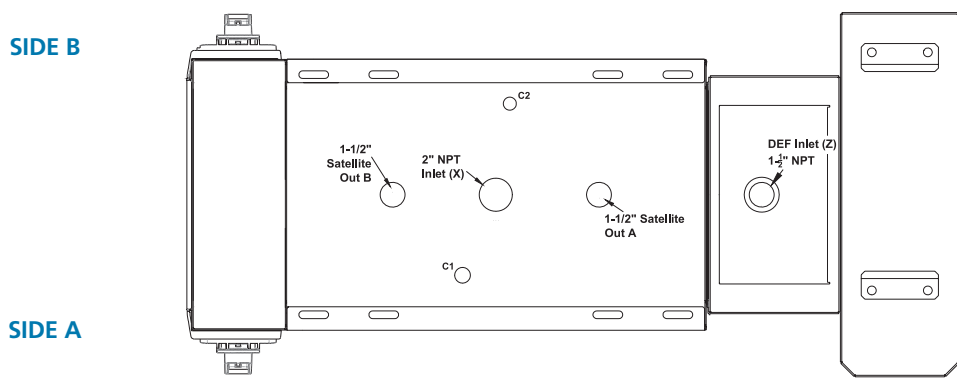

The HiFlo Loop System™ Ordering Guide



Ovation HS Strainer Options

DSLH-30-1535R-26

MOST COMMON

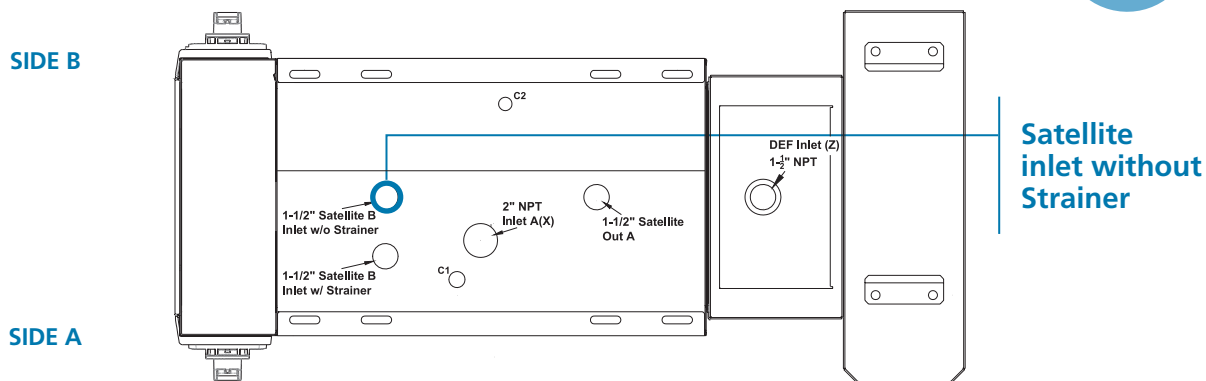

DSLH-30-1535RT-26

"T" option adds Strainer
(Only on wayne)

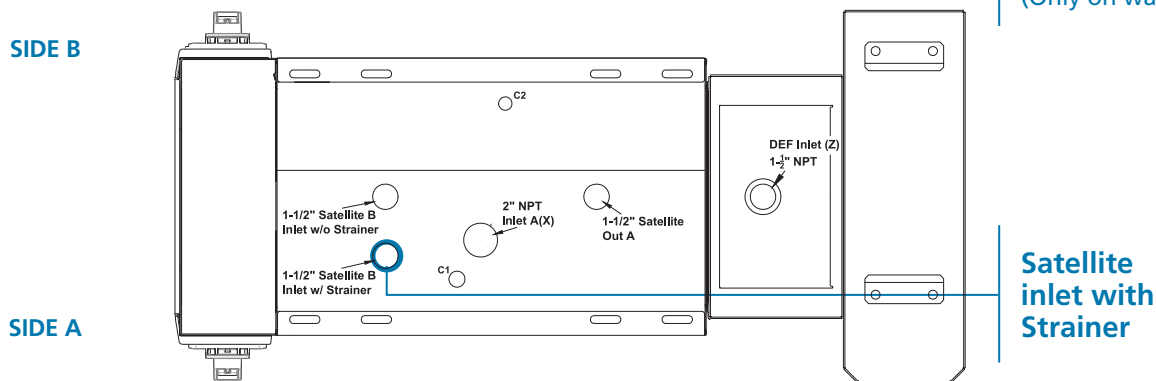

DEF Loop Configuration Ordering Guide*

Starting with 2010 models, DEF is now required in diesel-powered trucks utilizing Selective Catalytic Reduction (SCR) to meet federal emissions standards. The dispensing infrastructure at travel centers and fleet refueling sites continues to evolve as DEF-compatible equipment is installed. OPW's new 60V-DEF-SS Shear Valve body is made of 100% stainless-steel construction for unmatched compatibility. This double-poppet shear valve is third-party tested to ensure compatibility with the ISO 22241 Standard. With NPT connections on the top and NPT or NSPH threads on bottom of the loop-style valve, the 60V-DEF-SS shear valve provides peace of mind and minimizes damage to DEF-dispensing equipment in the case of impact collision, which will also help prevent product loss.

Benefits

- Compatible with Wayne Cold Weather Ovation w/DEF and Gilbarco Encore w/DEF
- Proprietary designed fully stainless-steel valve-body construction
- Utilizes a 1" NPT connection on the top and a 1.5" or 2" NPT/NPSH thread on the bottom for easy installation with a DEF-approved thread sealant, or DPC style couplings
- PEI RP1100 recommended materials used for double-poppet internals to contain product in the event of impact collision
- Machined shear groove for reliable shear performance
- Loop body version is designed to accommodate easy use with DEF recirculation systems



Shear Valve

Ordering Guide

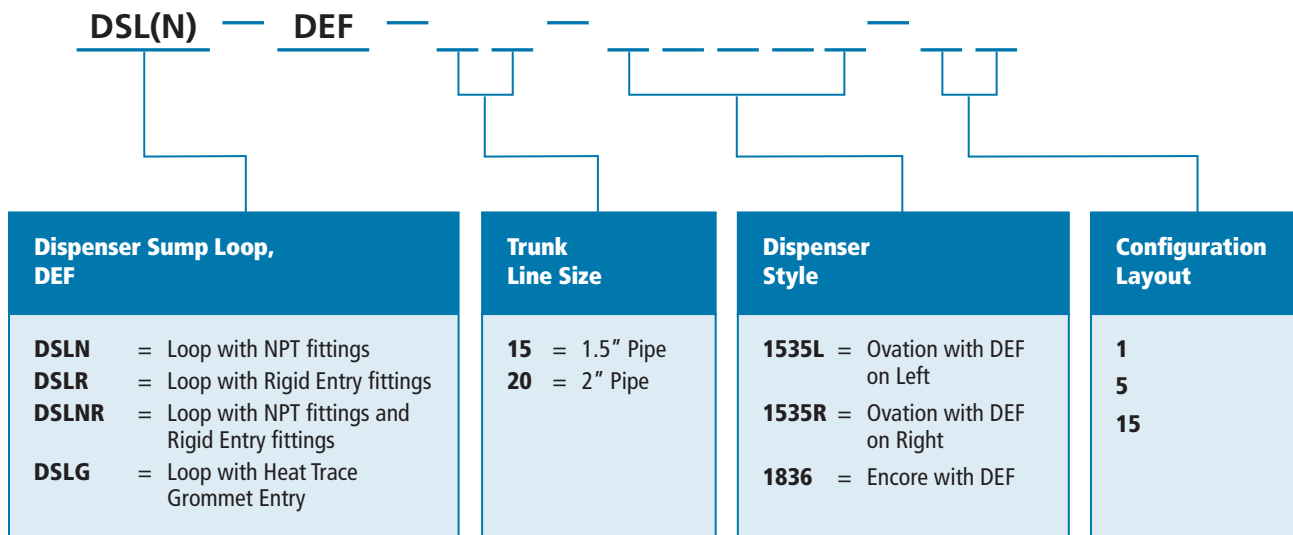

*A Side and B Side will change based on orientation.

DEF Loop Configuration Ordering Guide*



DEF for Ovation w/ Loop

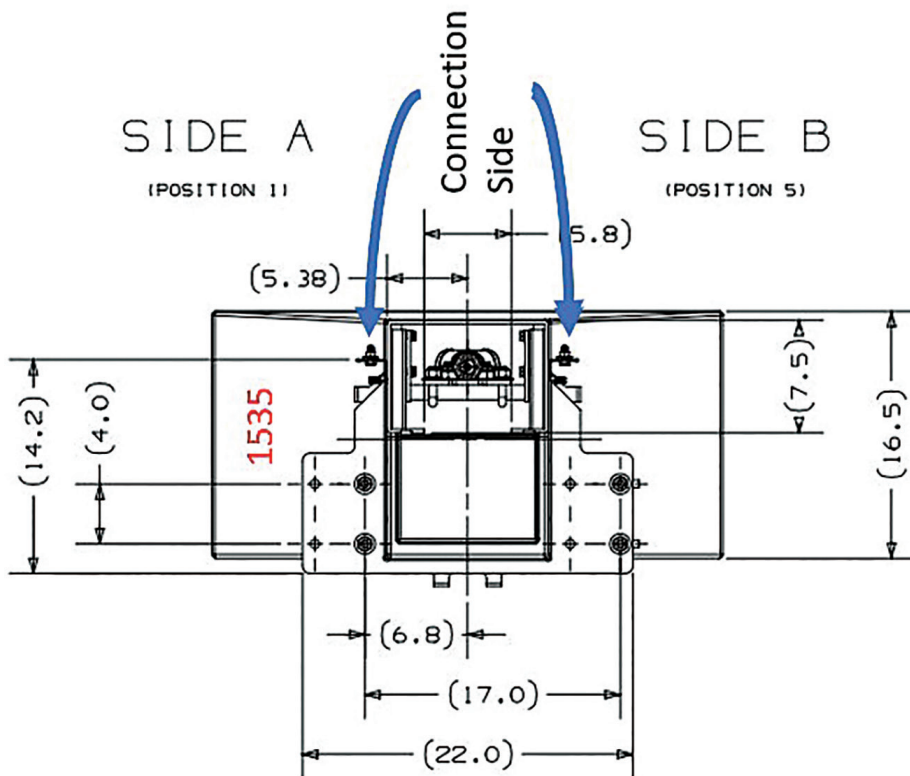

DEF for Encore w/ Loop

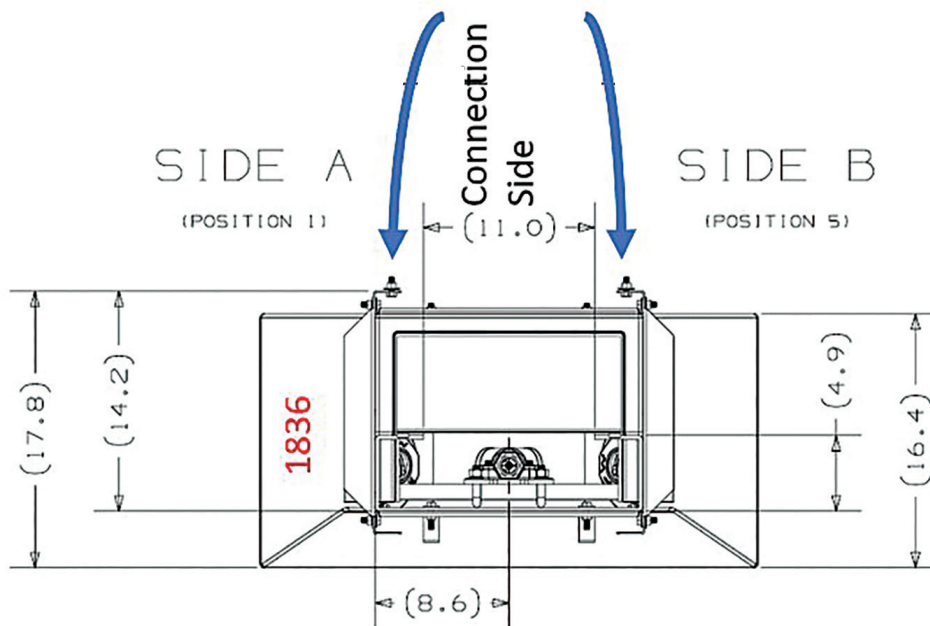

The Best - and Most Complete - Package in Underground Dispensing



From concept to completion, OPW provides a total solution that makes life easier for all parties.

Starting by simplifying the spec process, OPW saves plenty of headaches throughout the construction of its Loop System.

The plug-and-play nature of the system makes builds faster and more efficient, while providing an ease of service that is unparalleled. Distributors, contractors and fueling stations get to enjoy the innovative design of the Loop System and its benefits.

Contact your OPW District Manager today to learn more or visit [OPWRetailFueling.com](https://www.OPWRetailFueling.com).