

Flexible Entry Boots

These one-piece rubber boots are designed to seal pipe and conduit entries for both flat and curved surfaces. For proper installation, the appropriate size fabrication template should be used for accurate hole drilling. The appropriate sizes of hole saws must be used for the given *Flexible Entry Boot* size.

Step #1

Locate the center entry point in the flat wall section of the sump base and drill a 5/16" hole. Install the Entry Boot Template to the sump base wall using a 1/4" bolt and nut. Drill out one hole of the appropriate bolt hole circle for the size boot to be installed using the same 5/16" drill bit. Insert a second 1/4" bolt and nut through this hole to secure the template. Continue to drill the remaining holes of the bolt hole pattern. After drilling, remove the template from the sump base wall.

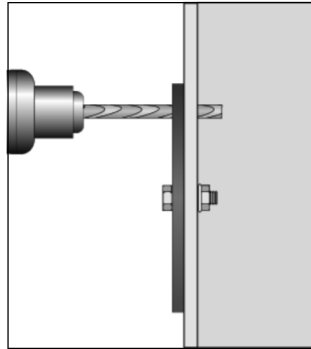

Step #2

Drill out the entry boot opening by using the appropriate size hole saw. After drilling out opening, clean rough edges with a razor knife or deburring tool.

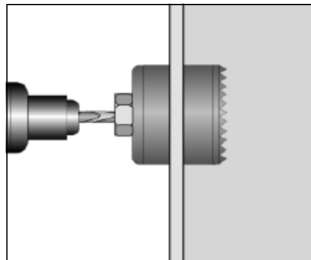

Hole Saw	Flexible Entry Boots
2-3/8"	EBF-0751
3-3/4"	EBF-0150, 0200, 0200F
5"	SAB-7400, EBF-0300
5.5"	EBF-0400
Sabre Saw	EBF-8600

Step #3

Install the entry boot from outside the sump by inserting the studs through the bolt holes. From the inside of the sump, install the compression ring over the studs with the raised lip facing away from the sump wall and install nuts by hand.

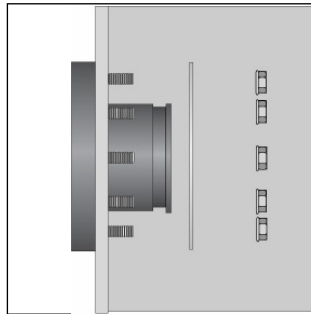

Entry Boot Sealants

OPW does not recommend the use of sealants when installing entry boots on poly sumps, however, the proper application of approved sealants on the sealing flange of our flexible entry boots is acceptable to OPW. The sealant(s) must be compatible with all contacted entry boot materials, all ground environments and any fuels that may be secondarily contained within the sumps being sealed. OPW in no way warrants the performance of the sealant and is in no way responsible for any environmental release resulting from the use of said sealant(s). All entry boots must be installed in accordance with OPW written installation instructions by a currently certified installer. If you choose to use a sealant, OPW recommends the following sealants for use with our entry boots and sumps: **Bostik 920 FS Fast Set, marine grade urethane sealant; SL-1100 Urethane Sealant; Thiokol 1100 Industrial polysulfide joint sealant or PR 1440 Class B Fuel Tank sealant.** *Note: Be sure all manufacturers' installation/application instructions are followed.*

WARNING

Keep all fiberglass cleaning solvents away from boots. These types of solvents could cause severe damage.

Step #4

Using a 7MM nut driver or wrench, tighten all of the nuts evenly in a clockwise sequence until 60 inch/lbs is attained on all nuts. This may require two to three revolutions to achieve. To prevent deformation of the boot, **do not over tighten nuts.**

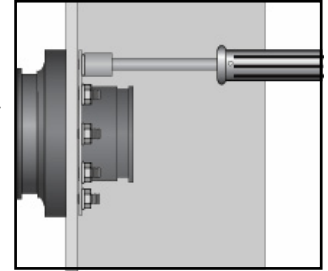

Step #5

Before inserting pipe, **insert foam backfill shield into entry fitting from outside the sump.**

Insert the appropriate sized pipe or conduit into the flexible boot from the outside of the sump. After the pipe or conduit has been positioned, install the band clamp around the boot and **tighten to 30 inch/lbs. Do not exceed 30 inch/lbs.**

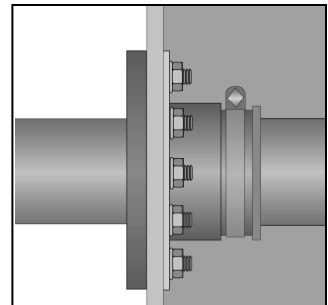

Angled Entries

The flexible entry boot is designed to permit angled pipe or conduit entries up to 15° off the centerline. Angles greater than 15° could prevent the boot from sealing around the pipe or conduit, and will void the product warranty.

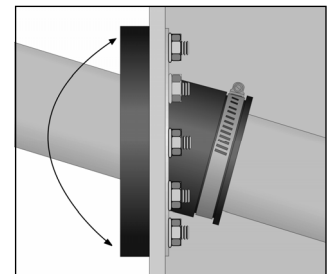

Round Fiberglass Surfaces

Flexible Entry Boots may be installed on round, smooth surfaces which have a diameter greater than 30". The installation procedures are the same as described above except, you must roll the template and mark each bolt hole. Extra care shall be taken to properly hand sand the surface where the entry boot is to be installed. Make sure all raised sections of FRP are minimized and remove all sharp edges. The 5/16" bolt holes should be made slightly larger after initial drilling. This can be accomplished by moving the 5/16" bit from side to side in each bolt hole after the *Entry Boot Template* has been removed. Tighten down each nut in stages so the boot flange and compression ring can evenly conform to the rounded surface and achieve a positive seal.

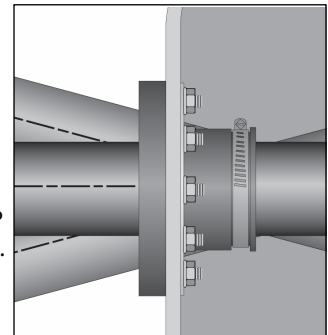

IMPORTANT

The appropriate hole saw size must always be used for proper installation of the *Flexible Entry Boot* and to maintain the product warranty.

A hydrostatic test must be performed to ensure a positive seal.

Double Entry Boots Installation Instructions

Double Entry Boots

These two-piece rubber boots are designed to seal pipe and conduit entries both inside and outside the containment chamber. The inner band clamp seals the pipe or conduit entry while the outer band clamp provides additional sealing against aggressive backfill conditions such as those present in high water areas. As with all entry boots, the appropriate hole saw sizes must be used for proper installation.

Step #1

Locate the center entry point in the flat wall section of the sump base and drill a 5/16" hole. Install the *Entry Boot Template* to the sump base wall using a 1/4" bolt and nut. Drill out one hole of the appropriate bolt hole circle for the size boot to be installed using the same 5/16" drill bit. Insert a second 1/4" bolt and nut through this hole to secure the template. Continue to drill the remaining holes of the bolt hole pattern. After drilling, remove the template from the sump base wall.

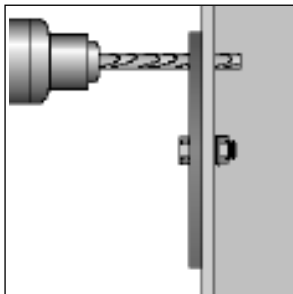

Step #2

Drill out the entry boot opening by using the appropriate size hole saw. After drilling out opening, clean any rough edges with a razor knife or deburring tool.

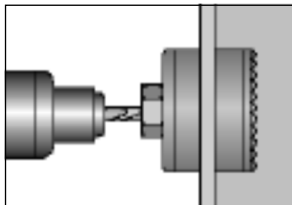

Hole Saw Double Entry Boots

2-3/8"	DEB-0751
4"	DEB-4015, 4020
4-1/4"	DEB-0150, 0200, 0200X, 4175
5-1/2"	DEB-0300, 0400, 0300X

(5-1/2" - All Access Pipe Double Entry Boots)

Step #3

Install the outer component of the entry boot from outside the sump by inserting the studs through the bolt holes. From the inside of the sump, install the inner component of the boot, compression ring and nuts as shown.

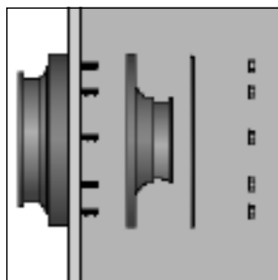

Step #4

Using a 7MM nut driver or wrench, tighten all of the nuts evenly in a clockwise sequence until 60 inch/lbs is attained on all nuts. This may require two to three revolutions to achieve. To prevent deformation of the boot, **do not over tighten nuts.**

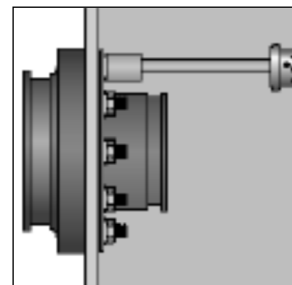

Step #5

When installing entry boots with reducer donuts, slip the appropriate Rubber Reducer Donut on to the piping as shown. Refer to the *OPW Price List* for available Donut sizes.

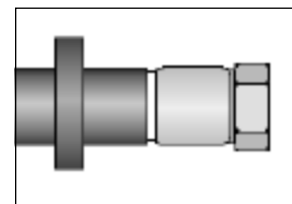

Step #6

Insert the pipe or conduit into the entry boot from outside of the sump. Align the Rubber Reducer Donut (if required) flush with the outer edge of the outer component of the Entry Boot as shown. For Coax Fittings, install a second Rubber Reducer Donut over the coupling and align with the front edge of the entry boot. Tighten the inner band clamp to 30 in. lbs. Tighten the outer band clamp to 30 inch/lbs. **Do not over tighten.**

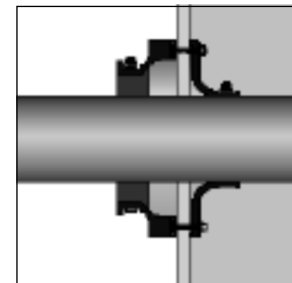

NOTE: When installing DEB-0200s with FlexWorks Pipe, you must install the entry boot prior to coupling the pipe.

WARNING

Keep all fiberglass cleaning solvents away from boots. These types of solvents could cause severe damage.

IMPORTANT

The appropriate hole saw size must always be used for proper installation of the Flexible Entry Boot and to maintain the product warranty.

3250 US 70 Business West * Smithfield, NC 27577
Customer Service: 1-(800) 422-2525 * Technical Service and Questions: 1-(877) OPW-TECH
www.opwglobal.com

