



Installation Instructions

Vent Transition Sump (VSE), Vent Rack System (VSR), Grade-Level Transition Sump (GSE)

IMPORTANT INFORMATION – FOLLOW ALL INSTRUCTIONS

OPW STANDARD PRODUCT WARRANTIES

FLEXWORKS by OPW, Inc., VAPORSAVER™ and all other OPW products must be used in compliance with all applicable federal, state, provincial and local laws, rules, and regulations. Product selection must be based on physical specifications and limitations, compatibility with the environment and material to be handled. All illustrations and specifications in the literature are based on the latest production information available at the time of publication. Prices, materials, and specifications are subject to change at any time, and models may be discontinued at any time, in either case, without notice or obligation. OPW warrants solely to its customer that the following products sold by OPW will be free from defects in materials and workmanship under normal use and conditions for the periods indicated:

Product	Warranty Period
FlexWorks Primary Pipe	10 years from date of manufacture
All Products Certified to California Standards*	1 year from date of manufacture or from date of installation registration (not to exceed 15 months from date of manufacture)
All other Products	1 year from date of manufacture
*Products certified to California 2001 Standards will have an OPW Registration Card enclosed/attached to the product.	

OPW's exclusive obligation under this limited warranty is, at its option, to repair, replace or issue credit (in an amount not to exceed the list price for the product) for future orders for any product that may prove defective within the applicable warranty period. (Parts repaired or replaced under warranty are subject to prorated warranty coverage for remainder of the original warranty period). Complete and proper warranty claim documentation and proof of purchase required. All warranty claims must be made in writing and delivered during the applicable warranty period to OPW at OPW 9393 Princeton-Glendale Road Hamilton, Ohio, USA 45011,

Attention: Customer Service Manager. No products may be returned to OPW without its prior written authority.

This limited warranty shall not apply to any FlexWorks or VAPORSAVER™ product unless it is installed by an OPW attested installer and all required site and warranty registration forms are completed and received by OPW within 60 days of installation. This limited warranty also shall not apply to any FlexWorks, VAPORSAVER™ or other OPW product: unless all piping connections are installed with a nationally-recognized or state-approved leak detection device in each tank and dispenser sump (which are not for storage and from which all discharge hydrocarbons must be removed, and the systems completely cleaned, within 24 hours); unless testable sumps utilize FlexWorks pipe and access fittings; unless a sump inspection log or an EPA recommended/required checklist is maintained and the results are furnished to OPW upon request; and unless OPW is notified within 24 hours of any known or suspected product failure and is provided with unrestricted access to the product and the site. This limited warranty also shall not apply to any product which has been altered in any way, which has been repaired by anyone other than a service representative authorized by OPW, or when failure or defect is due to: improper installation or maintenance (including, without limitation, failure to follow FlexWorks Quick Reference Manual Installation Guide and all product warning labels); abuse or misuse; violation of health or safety requirements; use of another manufacturer's, or otherwise un-authorized, substances or components; soil or other surface or subsurface conditions; or fire, flood, storm, lightning, earthquake, accident or any other conditions, events or circumstances beyond OPW's control.

THIS LIMITED WARRANTY IS IN LIEU OF ALL OTHER WARRANTIES, EXPRESS OR IMPLIED, AND ALL OTHER WARRANTIES INCLUDING, WITHOUT LIMITATION, THE WARRANTIES OF MERCHANTABILITY AND FITNESS FOR A PARTICULAR PURPOSE, ARE HEREBY EXCLUDED.

OPW shall have no other liability whatsoever, whether based on breach of contract, negligence, gross negligence, strict liability, or any other claim, including, without limitation, for special, incidental, consequential or exemplary damages or for the cost of labor, freight, excavation, clean-up, downtime, removal, reinstallation, loss of profit, or any other cost or charges. No person or entity is authorized to assume on behalf of OPW any liability beyond this limited warranty. This limited warranty is not assignable.

IMPORTANT: Read these assembly and installation instructions completely and carefully prior to starting. Check to make sure all parts have been provided. Use only the parts supplied; substitution of parts may cause product failure.

IMPORTANT: Please read all warnings and follow the installation instructions completely and carefully. Failure to do so will void all warranties and may cause product failure or result in environmental contamination due to liquid leakage into the soil, creating hazardous spill conditions.

WARNING - DANGER: Using electrically operated equipment near gasoline or gasoline vapors may result in fire or explosion, causing personal injury and property damage. Be sure that the working area is free from such hazards, and always use proper precautions.

Vent/Grade-Level Transition Sumps

OPW FlexWorks Vent Sumps for automotive fuels are installed at grade at the vent stack to provide access to and secondary containment where the underground vent piping connects to the rigid vent stack piping. Use only OPW Retail Fueling supplied hardware and components.

NOTE: Sump must be assembled and installed by a qualified person. The use of non-qualified personnel or any deviations from these recommended procedures could result in damage or leakage.

NOTE: Sumps have been evaluated per UL for use with REF, HEF, and AXP series of products. Failure to use recommended combinations of sump products in a completed assembly may cause damage or leakage.

NOTE: Sump products are not intended for storage in excessive temperatures or direct sunlight. Rough handling may cause damage and leaking in use. Visually inspect sump prior to installation to ensure no damage. Damaged sumps shall not be used.

Tools Needed for Installation and Assembly

Hole saw (4" and/or 5", per sump configuration)
Drill with 5/16" drill bit
Torque wrench
Phillips-head screwdriver
7/16" socket
9/16" socket (VSR only)
1/2" socket (VSR only)
7/8" combination wrench/adjustable wrench
Pipe wrench
Strap wrench
Level

NOTE: For Vent Rack System (VSR) Installation, see page 4

NOTE: For Grade-Level Transition Sump (GSE) Installation, see page 5

Vent Transition Sump (VSE)

Determine Burial Depth (see Figure 1)

Determine burial depth of the piping entering the sump and position the sump base to allow entry boots to have proper clearance from the bottom of the sump while maintaining adequate drop from sump to tank. Locate and drill entry fitting mounting holes per manufacturer recommendations.

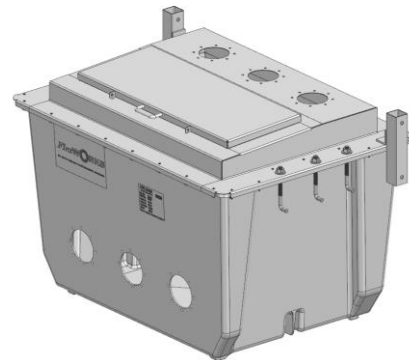

Figure 1

Install Sump Wall Entry Fittings (see Figure 2)

Install appropriate FlexWorks pipe and conduit entry fittings into the transition sump top at the proper locations. The location of each entry fitting should correspond with the vent line locations for the transition sump configuration that is to be installed. (Refer to the appropriate FlexWorks Entry Fitting Installation Instructions).

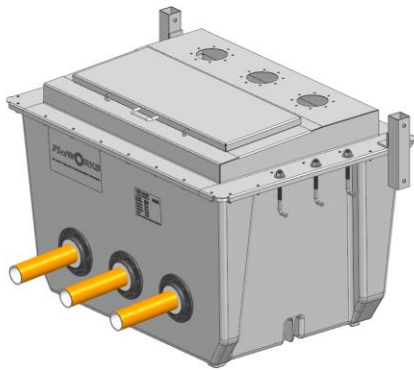

Figure 2

NOTE: When a FRP entry fitting is to be bonded to a FRP dispenser sump, surface preparation is **EXTREMELY IMPORTANT**. Follow all entry fitting manufacturer's recommendations for proper adhesion of the entry fitting. This includes sanding, cleaning, priming of bonding surfaces, and mixing and preparing of bonding materials. OPW recommends the use of Epoxy Acrylate Resins tested and approved for long-term use and exposure in automotive fueling station applications by UL.

Attach Sump Top

Although it is not required for concrete depths greater than 6" when measured from grade, Urethane Sealant (p/n SL-1100) can be used at the discretion of the installer. Apply a 1/8" minimum continuous bead of Urethane Sealant (p/n SL-1100) to the flat flange on the containment chamber just inside the slotted bolt holes. Attach the sump top to the containment chamber with the supplied screws and wing nuts and securely tighten using a Phillips screwdriver.

Install Upper Entry Fittings (see Figure 3)

Entry Fitting	For Use With
REF-0200V	2" Nom. Dia. Riser
REF-0300V	3" Nom. Dia. Riser

Install supplied FlexWorks pipe entry fittings to the upper lid assembly per manufacturer recommendations. Do not discard provided UV protection boots.

NOTE: The nylon nut should be facing upward, toward the outside of the sump. Leave nut loosely installed at this time.

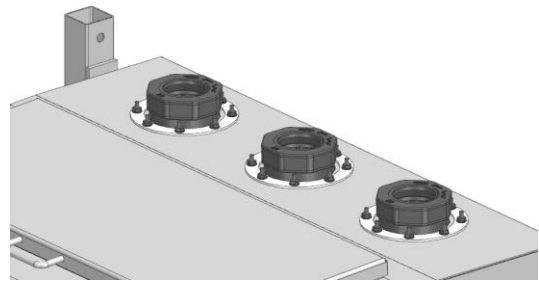

Figure 3

Install Riser Piping (see Figures 4 & 5)

Carefully insert the riser pipe through the UV protection boot and down the corresponding entry fitting. Make appropriate connections to vapor piping inside the sump using either flexible or rigid fittings, ensuring risers are plumb.

A pipe wrench must be used to secure lower section of the riser pipe. Tighten the nylon nut with a strap wrench until the end of the grommet is flush with the face of the nut (approximately 3.5 turns).

Slide UV boot down over the entry fitting so that it sits flush against the lid.

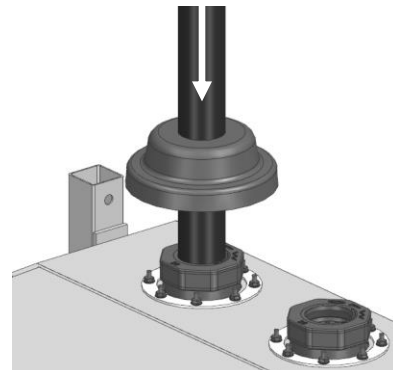

Figure 4



Figure 5

NOTE: Verify nuts on all anchor bolts and hardware connecting the top and base are secured tightly before proceeding to backfilling and pouring concrete. See Figure 6.

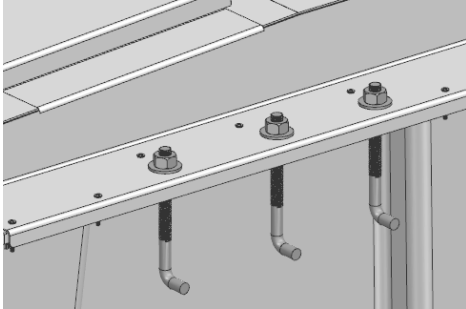

Figure 6

Backfill Piping and Sump

Ensure sump is set level. Rounded pea gravel with a minimum diameter of 1/8" and a maximum diameter of 3/4" must be used for backfilling around OPW Sumps. To prevent sump damage, avoid dumping pea gravel directly onto the Transition Sump when backfilling. Backfill equally around the sump in layers to prevent damage or deformation. Ensure proper backfill with no voids under sump bottom and joint.

Pour Concrete Pad (see Figure 7)

A concrete pad must be installed to counter the buoyancy effects of the sump. A minimum of 6 cubic feet of reinforced concrete must be installed. A minimum 12" wide by 6" deep around the perimeter of the sump is required.

IMPORTANT: If installing optional VSR rack system, see **Vent Rack System** for instructions prior to pouring concrete.

NOTE: Concrete shall not be poured higher than 1" above the base of lid assembly. Use caution as to avoid pouring into rack mounting couplings.

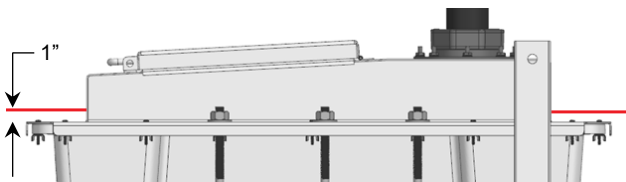

Figure 7

NOTE: Vent stacks must be supported and tied together in at least one position; either against an existing structure or by way of an anchored rack system. In areas prone to high winds and severe weather conditions, additional support may be

required. Refer to local codes and regulations for proper support information.

Vent Rack System (Optional) OPW Part No. VSR-4, VSR-8, VSR-12

VSR-4 Installation (see Figures 8 & 9)

Install anchor bolts in the lower holes on each of the two couplers located on the steel top. Slide a length of 2" x 2" square tubing into each coupler, using the anchor bolt as a bottom stop. Fasten together through the uppermost holes using included hardware.

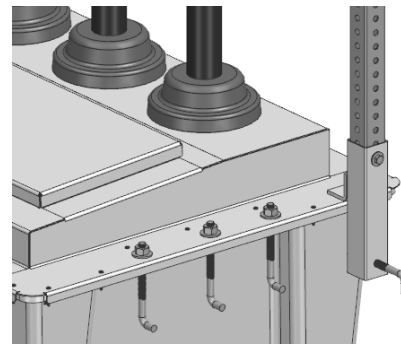

Figure 8

Attach horizontal strut to each section of square tubing with provided hardware ensuring strut remains level. Each vent stack shall be secured to the horizontal strut via an appropriately sized pipe clamp (sold separately).



Figure 9

VSR-8 and VSR-12 Installation (see Figure 10)

Follow VSR-4 installation instructions to install 4-foot rack section. To increase rack height to 8 feet, slide couplers on each section of square tubing and fasten to secure.

NOTE: The coupler should overlap each section of tubing by a minimum of three (3) holes.

Tighten horizontal strut to the square tubing with provided hardware to 20-25 ft-lb, ensuring the strut remains level. Repeat this procedure to increase rack height to 12 feet.

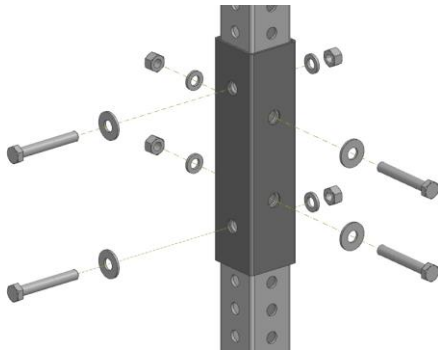

Figure 10

Grade-Level Transition Sump (GSE)

Determine Burial Depth (see Figure 11)

Determine burial depth of the piping entering and/or exiting the sump and position the sump base to allow entry boots to have proper clearance from the bottom of the sump while maintaining adequate drop from sump to tank. Locate and drill entry fitting mounting holes per manufacturer recommendations.

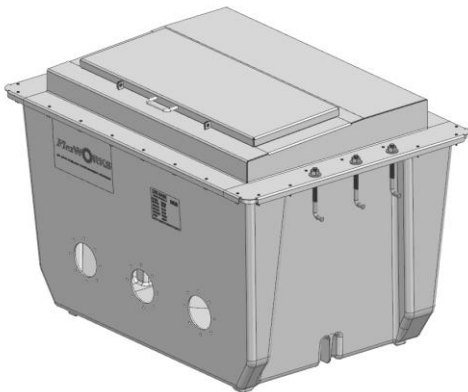

Figure 11

Install Sump Wall Entry Fittings (see Figure 12)

Install appropriate FlexWorks pipe and conduit entry fittings into the transition sump top at the proper locations. The location of each entry fitting should correspond with piping locations for the transition sump configuration that is to be installed. (Refer to the appropriate FlexWorks Entry Fitting Installation Instructions).

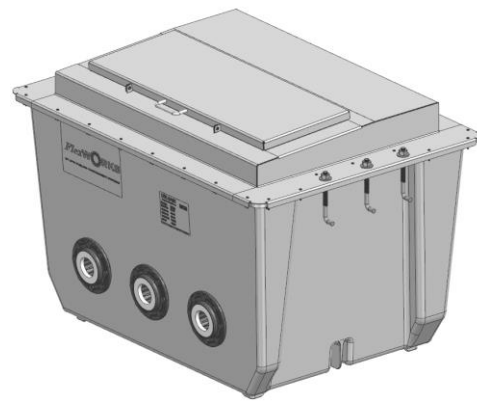

Figure 12

NOTE: When a FRP entry fitting is to be bonded to a FRP dispenser sump, surface preparation is **EXTREMELY IMPORTANT**. Follow all entry fitting manufacturer's recommendations for proper adhesion of the entry fitting. This includes sanding, cleaning, priming of bonding surfaces, and mixing and preparing of bonding materials. OPW recommends the use of Epoxy Acrylate Resins tested and approved for long-term use and exposure in automotive fueling station applications by UL.

NOTE: When installing entry fittings to the upper lid assembly follow manufacturer's installation recommendations. Drill **ONLY** in area highlighted in Figure 13.

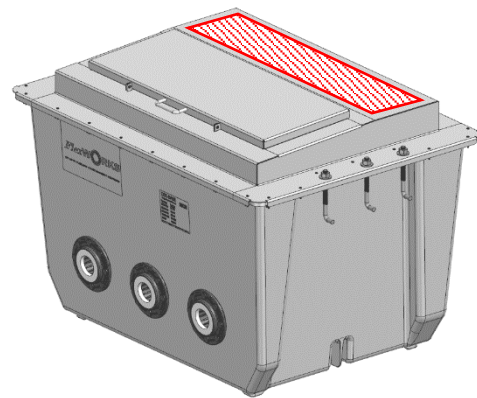

Figure 13

Attach Sump Top

Although it is not required for concrete depths greater than 6" when measured from grade, Urethane Sealant (P/N SL-1100) can be used at the discretion of the installer. Apply a 1/8" minimum continuous bead of Urethane Sealant (P/N SL-1100) to the flat flange on the containment chamber just inside the slotted bolt holes. Attach the sump top to the containment chamber with the supplied screws

and wing nuts and securely tighten using a Phillips screwdriver.

Make Internal Connections

Make appropriate connections to piping inside the sump using either flexible or rigid fittings, ensuring all fittings are properly torqued to manufacturer's recommendations.

NOTE: Verify nuts on all anchor bolts and hardware connecting the top and base are secured tightly before proceeding to backfilling and pouring concrete. See Figure 14.

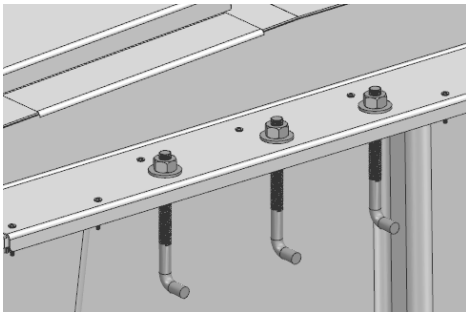

Figure 14

Backfill Piping and Sump

Ensure sump is set level. Rounded pea gravel with a minimum diameter of 1/8" and a maximum diameter of 3/4" must be used for backfilling around OPW Sumps. To prevent sump damage, avoid dumping pea gravel directly onto the Transition Sump when backfilling. Backfill equally around the sump in layers to prevent damage or deformation. Ensure proper backfill with no voids under sump bottom and joint.

Pour Concrete Pad (see Figure 15)

A concrete pad must be installed to counter the buoyancy effects of the sump. A minimum of 6 cubic feet of reinforced concrete must be installed. A minimum 12" wide by 6" deep around the perimeter of the sump is required.

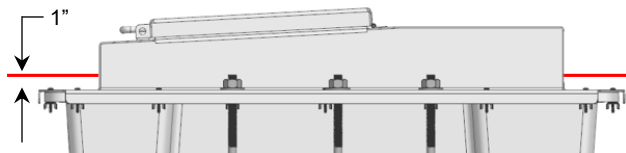

Figure 15

NOTE: Concrete shall not be poured higher than 1" above the base of lid assembly.

Operation and Maintenance

The FlexWorks System is designed to provide reliable underground fuel transfer and short-term secondary containment of leaked petroleum product.

FlexWorks sumps and secondary containment pipes are not intended for long term storage of petroleum products. Liquid that accumulates in the secondary containment system must be promptly removed and properly disposed of. Operational third party approved liquid sensors should be installed and maintained in each sump to reliably indicate to the operator that liquid is present in the secondary containment system. Once a leak is detected, the system must be shut down immediately and the source of the leak must be repaired. All liquid must be thoroughly flushed and cleaned out of the secondary containment system at once. Inspect all system components at least monthly for leaks or damage, and repair or replace any suspect component as necessary.

Visual inspections of all containment sumps and components should be made on a routine basis to check for damage, water infiltration or for any signs of leaking product. An electronic or mechanical shut-off leak detection system is recommended for all containment sumps. Sumps are to be kept free of debris and spilled fuel.

NOTE: Failure to remove fuel and liquids from containment sumps may compromise the performance and integrity of the sump and its associated fittings and seals over prolonged periods of time.

NOTE: Common sense and good judgment should always be exercised. The contractor's understanding of all related site conditions prior to starting the project is essential. If the contractor does not have a clear understanding of the required work and site conditions, the contractor is advised to seek clarification prior to starting any portion of the project.



Part Number: 218648
Issue Date: 05-22-2024, Rev A