



FUELED BY EXCELLENCE

Product Catalog
Retail & Commercial Fueling Products



www.opwretailfueling.com

FUELED BY EXCELLENCE



DEFINING | WHAT'S NEXT IN FUELING SOLUTIONS WORLDWIDE

Since 1892, OPW has been Leading the Way and Defining What's Next in fluid-handling solutions worldwide. The OPW brand represents an implicit promise of trust to its customers and distributors. A promise backed by an unparalleled heritage of innovation, quality, reliability, safety, efficiency, sustainability and availability.

As an organization, OPW Retail Fueling consists of three global operating units worldwide and multiple manufacturing operations in North America, Europe, United Kingdom, China and India, and sales offices around the globe. OPW Retail Fueling is part of the Clean Energy & Fueling segment of Dover Corporation (NYSE: DOV).

It is our mission to revolutionize fluid-handling and refueling operations globally by optimizing safety, efficiency, reliability and environmental sustainability through innovative fluid handling, piping and containment, valves and fittings, and refueling nozzles.

Combine OPW Retailing Fueling's aboveground and underground solutions and you get the only end-to-end solution from a single source in the industry – an integrated solution where every component is designed and manufactured to work in unison and provide the petroleum industry's most comprehensive and innovative refueling system.

OPW Retail Fueling consists of four key areas of operation – Nozzles and Accessories, Underground Storage Tank Equipment, Piping & Containment Systems, and CleanEnergy Fueling Products. Specifically designed to optimize fuel-transfer efficiency and environmental protection at commercial and retail-fueling sites, OPW is the brand specified by more fueling operators worldwide than any other.

We are a brand known as much for our character as for our great products. Operators around the world know they can trust OPW to consistently deliver the kind of high-quality fluid-handling solutions they need to meet their business requirements and to help them fulfill their individual goals of social and environmental responsibility today and into the future.



Nozzles & Accessories



Underground Storage



Piping & Containment



CleanEnergy

RETAIL FUELING



TABLE OF CONTENTS

UNDERGROUND PRODUCTS

PIPING & CONTAINMENT SYSTEMS

FlexWorks Supply Piping	6 - 7
Access Pipe	8
FlexWorks Vent Piping	9
Pipe Couplings & Fittings	10 - 12
Flexible Piping Installation Tools	13 - 15
Tank Sumps	16 - 19
Sump-Mounting Flanges	21
FlexWorks Loop System	22 - 34
Dispenser Sump Selection Chart	35 - 36
Dispenser Sumps / Pans	37 - 43
DEF Containment Sumps	44
Dispenser Sump Accessories	45
Automatic Fire-Extinguisher System	46
Sump Entry Fittings	47 - 49
Test Boots & Testing Equipment	50
Fuel Oil & Generator Piping Systems	51
Transition & Special Application Sumps	52 - 57

EMERGENCY SHUT-OFF VALVES

Emergency Shut-off Valves	59 - 62
Vapor-Line Shear Valves	63 - 64
DEF Shear Valve	65
Island Forms & Protective Curbing	66 - 69
Flexible Connectors	70 - 71
Suction-System Accessories	72

UNDERGROUND STORAGE TANK EQUIPMENT

Phase I CARB-Certified Enhanced Vapor Recovery (EVR) Product Overview	74 - 75
Phase I CARB-Certified Enhanced Vapor Recovery (EVR) Torque Specs.....	76
Spill-Containment Manholes	77 - 92
Multiport Spill-Containment	93 - 100
Spill Container Product Identification Tags	101
Fill-Pipe Connection Equipment	102 - 113
Overfill-Prevention Equipment	114 - 124
Tank-Venting Equipment	125 - 128
Manholes & Monitoring Well Equipment	129 - 139

TABLE OF CONTENTS (cont.)

ABOVEGROUND PRODUCTS

CONVENTIONAL AUTOMATIC NOZZLES

Automatic Nozzles	141 - 157
Extreme Cold-Weather Nozzles	148
Custom Hand Insulator Imprinting	149
OPW AdMaster™	149
Factory-Assembled Hose Kits	150
11AF® 3/4" Automatic Nozzles	151
Heavy-Duty, High-Flow Truck, Bus & Fleet Service Nozzle	152 - 153
OPW NEWGARD™ Hand Insulators	154
21Gu™ DEF Nozzle	155 - 157

SWIVELS AND BREAKAWAYS

Swivels and Breakaways	159 - 166
Flow Limiters	167

VACUUM-ASSIST SWIVELS & BREAKAWAYS

12VW Vacuum-Assist Nozzle	169 - 170
Vacuum-Assist Swivels, Breakaways & Accessories	171 - 172

BALANCE VAPOR RECOVERY HANGING HARDWARE

Balance Breakaways & Accessories	176
--	-----

INDUSTRIAL PRODUCTS

DEF Bulk Nozzle	178
Automatic Bulk-Fueling & Aircraft Nozzles	179 - 183
Manual High-Flow Bulk-Fill Nozzles	184 - 188
Manual Nozzle Accessories	189
Manual Utility Farm Nozzle	190
Swivels & Breakaways	191 - 192

HOSE RETRACTORS

Spring-Balance Hose Retractors	193 - 196
Counterweight Hose Retractors (MPD)	197

ABOVEGROUND STORAGE TANK EQUIPMENT

Spill Containment	199 - 200
Overfill Prevention	201 - 202
Fuel-Delivery Coupler & Accessories	203
Mechanical Tank Gauges	204
Tank Alarms	205

Tank Venting	206 - 209
Anti-Siphon Valves	210
Solenoid Valves	211
Emergency Shut-Off Valves	212

CLEAN ENERGY FUELING

CNG Fueling Nozzles	213 - 214
---------------------------	-----------

CUSTOMER RESOURCES

Fuel Compatibility Matrix	216 - 218	Instruction Manual Index	229 - 231
Approvals, Listings and Certifications	219 - 228	Standard OPW Warranty	232

Piping Layout (Pressure System)

Tank Sumps, Tank Sump Systems and Accessories

- ◆ FlexWorks Vent Piping – (pg. 9)
- ◆ Fiberglass Sumps and Components – (pgs. 16 - 19)
- ◆ Resin Sumps and Components – (pgs. 18, 19)
- ◆ Polyethylene Tank Sumps – (pg. 20)
- ◆ Tank Sump Systems – (pgs. 16 - 19)
- ◆ Transition Sumps – (pg. 52)
- ◆ Special Application Sumps – (pg. 57)
- ◆ Mounting Flanges – (pg. 21)

FlexWorks Flexible Supply Piping

- ◆ C15A, C20A (pgs. 6 - 7)

Access Piping

- ◆ AXP40 (pg. 8)

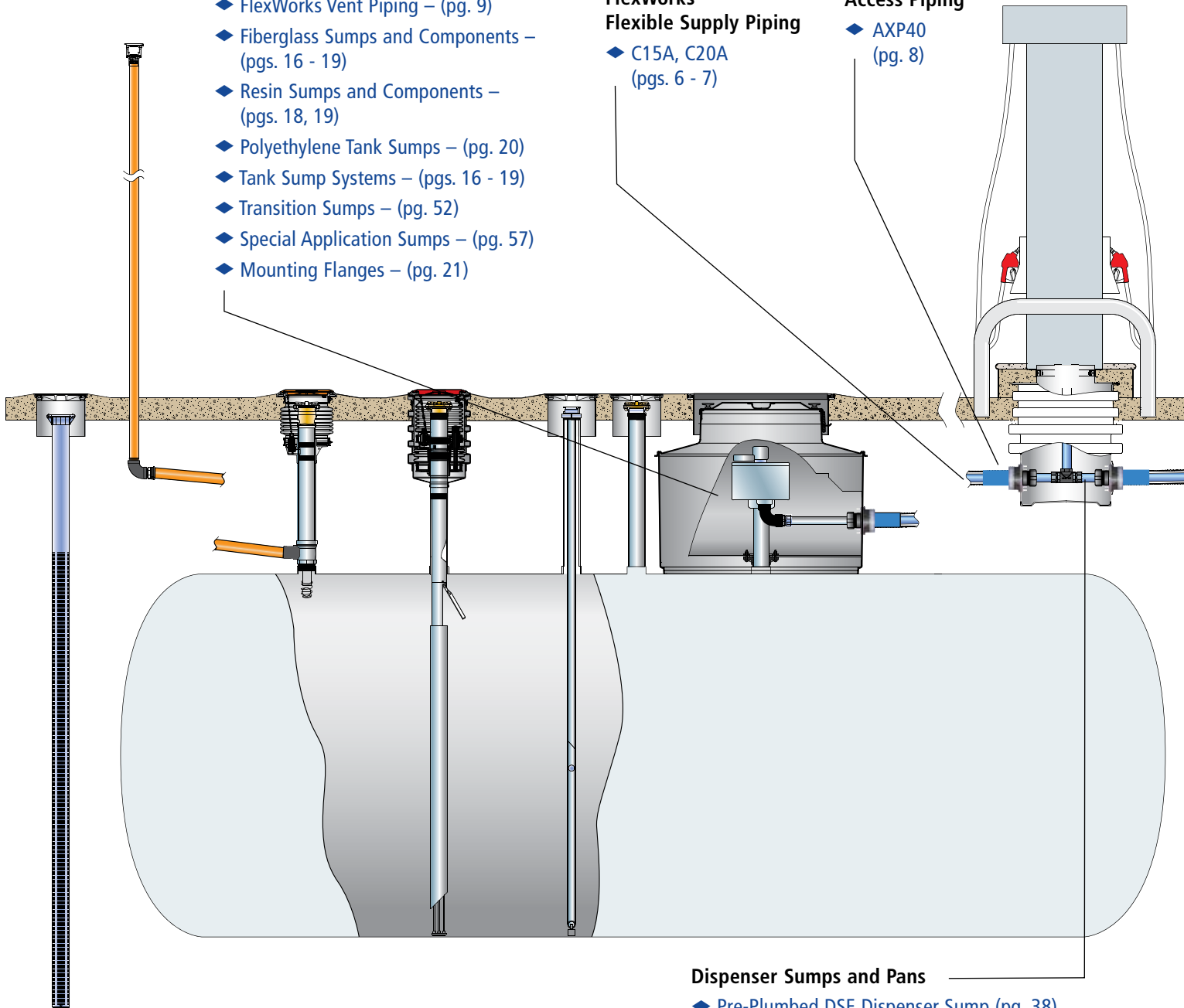

Dispenser Sumps and Pans

- ◆ Pre-Plumbed DSE Dispenser Sump (pg. 38)
- ◆ Wide-Access Polyethylene (pg. 41)
- ◆ Polyethylene Pans (pg. 43)
- ◆ DSE Dispensing Sump (pg.37)
- ◆ Wide-Access Fiberglass (pg. 40)
- ◆ Dispenser Sump Accessories (pg. 45)
- ◆ Dispenser Sump Selection Chart (pgs.35 - 36)
- ◆ DEF Containment Sumps (pg. 44)



The complete Environmental System for underground fuel transfer and containment for the 21st century.

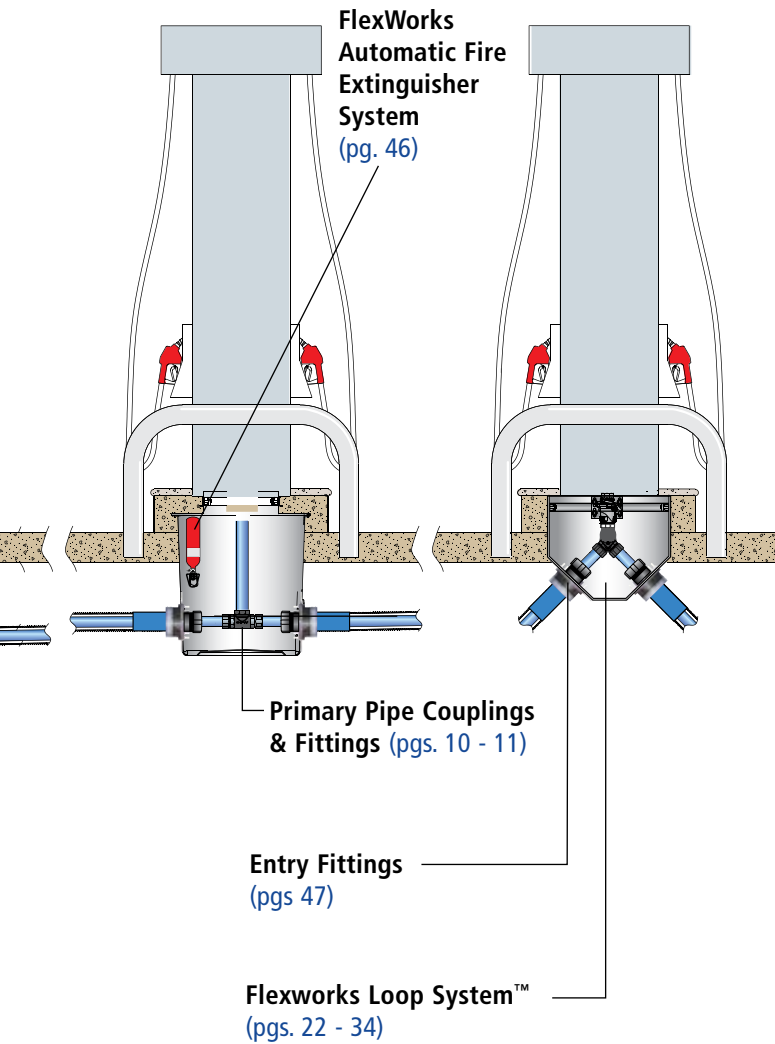

OPW Innovative Fueling Solutions

The heart of FlexWorks is an advanced, flexible piping system that can be installed quickly and easily in a variety of configurations. Flexible piping eliminates the need for buried piping joints, which are notorious leak points in rigid piping systems. In a pressure system, the submersible pump is connected in series directly to the dispensers with a continuous run of flexible pipe. In a suction system, a continuous run of flexible pipe connects the tank to the suction pump dispenser. All piping connections at the tank and dispensers are contained in sumps.

The primary fuel pipe is available with an integral secondary containment pipe, which can be inserted into a dual-layer, corrugated access pipe. The crush-resistant access pipe protects the primary pipe from the backfill while serving as an added layer of protection. The access pipe also affords the added advantage of primary pipe retractability. Future inspection, repair or replacement of the primary pipe is achievable without excavation.

The FlexWorks System features highly integrated components that interconnect seamlessly to provide reliable secondary containment. FlexWorks dispenser sumps are custom made for each particular dispenser footprint. FlexWorks tank sumps afford raintight containment for and accessibility to submersible pumps and UST equipment. A variety of FlexWorks entry fitting styles and sizes ensure the availability of a custom-designed solution for virtually every piping application.

FlexWorks by OPW is the complete Environmental System for underground fuel transfer and containment for the 21st century.

**Listings and
Certifications**



**FlexWorks
Supply Piping**

Why flex pipe?

OPW developed FlexWorks pipe in response to customer feedback. You asked and we delivered! The pipe is more flexible, lighter and has reduced memory. Pipe can also be replaced without breaking concrete.

Elimination of potential underground leak points

- ◆ No underground fittings or joints
- ◆ No hand-built field joints
- ◆ All termination points are contained safely inside sumps
- ◆ Termination joints are precision coupled to simulate factory-made assemblies

Light, Flexible & Easy to Install. ULc Approved for All Fuels

ULc APPROVAL

- ✓ Motor Vehicle Fuels
- ✓ High Blend Fuels
- ✓ Concentrated Fuels
- ✓ Aviation and Marine



THE WORLD'S MOST SPECIFIED FLEXIBLE FUEL-TRANSFER PIPE

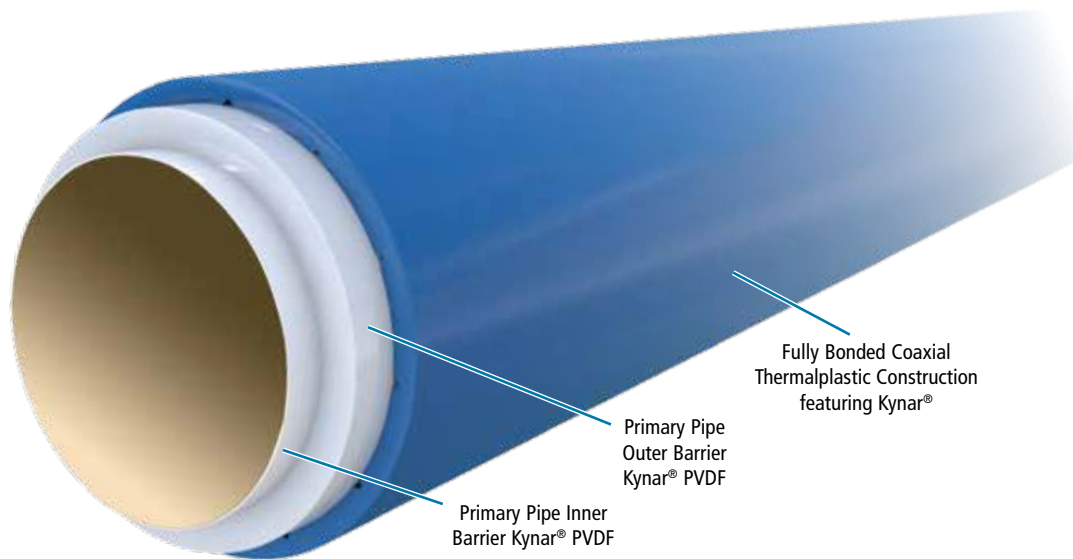

What Makes This Pipe Different? Lower installation costs

- ◆ Eliminates the hassles – installation time and potential leak points of rigid pipe installations
- ◆ Fast and easy installation – results in less installation labor, time and cost
- ◆ Eliminates burdensome cutting, fitting, and cleaning
- ◆ No adhesives – heat assists, curing problems or electrofusion welding of joints
- ◆ Easy to bend – no special fittings to install in order to make bends

Double-Wall Flexible Vent Piping: UL971-Listed, Integral Primary/Secondary, Normal Vent & Vapor Piping, Gasoline, Aviation & Marina Fuels:

A UL-listed, double-wall, flexible supply piping system is designed for installation within access piping (not required but recommended). The outer containment pipe includes inner stand-off ribs to create a small interstitial space which allows for optimum fluid migration, continuous monitoring and easy periodic testing. This piping features an enhanced construction that meets the new UL971 standard. OPW's FlexWorks double-wall piping has both the primary and secondary containment pipe UL-listed and is labeled as follows:
INTEGRAL PRIMARY/SECONDARY FOR MOTOR VEHICLE FUELS.

Flexible Piping Manual Order Number: UPM-0001

FlexWorks Supply Piping

OPW's FlexWorks Pipe is more flexible, lighter and has reduced memory to aid installation and is UL approved for all fuels.

Ordering Specifications - Sizing Matrix

Double Wall Pipe								
Part #	Description	Packaged		Box/Reel Size		Box/Reel Weight		Specifications
				In.	lbs.	kg		
C075A-250	3/4" Double Wall Primary Pipe	250 ft	Box	44x44x25	134	61		
C075A-1000	3/4" Double Wall Primary Pipe	1000 ft	Reel	58x58x48	527	239		
C075A-CLXXX	3/4" Double Wall Primary Pipe	10-990 ft	Box					Custom Box/ Reel 10-990 ft (XXX enter feet in 10 ft increments)
C10A-250	1" Double Wall Primary Pipe	250 ft	Box	44x44x25	169	77		
C10A-1000	1" Double Wall Primary Pipe	1000 ft	Reel	58x58x48	605	724		
C10A-CLXXX	1" Double Wall Primary Pipe	10-990 ft	Box					Custom Box/Reel 10-990 ft (XXX enter feet in 10 ft increments)
C15A-250	1.5" Double Wall Primary Pipe	250 ft	Reel	38x45x30	240	109		
C15A-350	1.5" Double Wall Primary Pipe	350 ft	Reel					
C15A-375	1.5" Double Wall Primary Pipe	375 ft	Reel					
C15A-500	1.5" Double Wall Primary Pipe	500 ft	Reel	58x58x48	605	274		
C15A-1000	1.5" Double Wall Primary Pipe	1000 ft	Reel	58x58x48	980	444		
C15A-1400	1.5" Double Wall Primary Pipe	1400 ft	Reel					
C15A-1225	1.5" Stick Pipe Double Wall - 25 ft	25 ft each	12 per Box					Sold Box of 12 – Minimum order 300 ft
C15A-1228	1.5" Stick Pipe Double Wall - 28 ft	28 ft each	12 per Box					Sold Box of 12 – Minimum order 336 ft
C15A-1230	1.5" Stick Pipe Double Wall - 30 ft	30 ft each	12 per Box					Sold Box of 12 – Minimum order 360 ft
C15A-1233	1.5" Stick Pipe Double Wall - 33 ft	33 ft each	12 per Box					Sold Box of 12 – Minimum order 396 ft
C15A-1240	1.5" Stick Pipe Double Wall - 40 ft	40 ft each	12 per Box					Sold Box of 12 – Minimum order 480 ft
C20A-250	2" Double Wall Primary Pipe	250 ft	Reel	63x63x33	192	87		
C20A-375	2" Double Wall Primary Pipe	375 ft	Reel					
C20A-500	2" Double Wall Primary Pipe	500 ft	Reel	68x68x48	770	349		
C20A-800	2" Double Wall Primary Pipe	800 ft	Reel					
C20A-1225	2" Stick Pipe Double Wall - 25 ft	25 ft each	12 per Box					Sold Box of 12 – Minimum order 300 ft
C20A-1228	2" Stick Pipe Double Wall - 28 ft	28 ft each	12 per Box					Sold Box of 12 – Minimum order 336 ft
C20A-1230	2" Stick Pipe Double Wall - 30 ft	30 ft each	12 per Box					Sold Box of 12 – Minimum order 360 ft
C20A-1233	2" Stick Pipe Double Wall - 33 ft	33 ft each	12 per Box					Sold Box of 12 – Minimum order 396 ft
C30A-100	3" Double Wall Primary Pipe	100 ft	Reel					
C30A-250	3" Double Wall Primary Pipe	250 ft	Reel	63x63x33	192	87		
C30A-375	3" Double Wall Primary Pipe	375 ft	Reel					
C30A-500	3" Double Wall Primary Pipe	500 ft	Reel	68x68x48	770	349		
C30A-600	3" Double Wall Primary Pipe	600 ft	Reel					
C30A-0522	3" Stick Pipe Double Wall - 22 ft	22 ft each	Box					Sold Box of 5 - Minimum order 110 ft
C30A-0528	3" Stick Pipe Double Wall - 28 ft	28 ft each	Box					Sold Box of 5 - Minimum order 140 ft

Double Wall Vent Pipe				
V20-125B	2" Double Wall Vent Pipe	125 ft	Box	
V20-250	2" Double Wall Vent Pipe	250 ft	Reel	
V20-500	2" Double Wall Vent Pipe	500 ft	Reel	
V30-125	3" Double Wall Vent Pipe	125 ft	Reel	
V30-250	3" Double Wall Vent Pipe	250 ft	Reel	
V30-500	3" Double Wall Vent Pipe	500 ft	Reel	

Product #	Size		Description	Minimum Bend Radius		Working Pressure		Temperature Rating		Burst Pressure	Max Vacuum for Suction
	in.	cm		in.	mm	PSIG	Bar	F	C		
C075A	3/4	1.9	Double-Wall Primary Pipe	18	457	145	10 bar	-20° to +120° F	-29° to +49° C	Exceeds 5X Working Pressure	26" of Mercury for All Pipe
C10A	1	2.54	Double-Wall Primary Pipe	18	457	125	8.6 bar				
C15A	1.5	3.8	Double-Wall Primary Pipe	24	610	100	6.9 bar				
C20A / V20	2	5	Double-Wall Primary Pipe / Vent Pipe	36	914	75	5 bar				
C30A / V30	3	7.6	Double-Wall Primary Pipe	72	1828	75	5 bar				

Note: Discounted short runs available while supplies last. Please contact Customer Service for availability and pricing.
 * OPW also offers short and custom lengths of pipe, as well as pipe packaged and shipped on Mega Reels. Please contact our Customer Service department at 1-800-422-2525, or visit us on the web at www.opwglobal.com for the most up-to-date information.

Listings and Certifications   

Access Pipe

A 4" or 6" diameter corrugated flexible conduit is used to provide access to and permit the future replacement of the flex piping if desired. This corrugated pipe is strong enough to withstand H-20 loading requirements when properly buried and thick enough to minimize damage from shipping and jobsite handling. Access pipe can accommodate the 3/4", 1", 1-1/2", 2" and 3" FlexWorks supply pipe.

Features & Benefits:

- ◆ Crush and puncture-resistant
- ◆ Semi-smooth liner facilitates ease of installation
- ◆ Saves you time and money
- ◆ No buried joints



Ordering Specifications - FlexWorks Access Pipe

Part #	Application	Minimum Bend Radius		Packaging	Dimensions				Box Size	Weight		
					I.D.		O.D.			in.	lbs.	kg
		in.	mm		in.	mm	in.	mm				
AXP40-100	4" Dual Layer Access Pipe	18"	457	Box 100 ft.	4	102	4.760	121.0	42x42x32	115	52	
AXP40-250	4" Dual Layer Access Pipe	18"	457	Box 250 ft.	4	102	4.760	121.0	60x60x32	218	99	
AXP60-500	6" Access Pipe	36"	914	Box 500 ft.	6	152	7.100	180.0	96x60x32	485	220	
AXP60-100	6" Access Pipe	36"	914	Box 100 ft.	6	152	7.100	180.0	48x48x32	125	57	
AXP40-Connect	4" Connection Boot									1		

Access Pipe Installation Instructions Sheet Order Number: **API-0001**

**FlexWorks
Vent Piping**

Why flex pipe for venting?

OPW developed FlexWorks Vent Pipe in response to customer feedback and alternatives to FRP vent piping. You asked and we delivered! The pipe is more flexible, lighter and has reduced memory. Our vent pipe is available with the typical short lead times you have come to enjoy from OPW!

Elimination of potential underground leak points

- ◆ Continuous piping runs between tank and vent stacks
- ◆ No hand-built field joints
- ◆ Stainless-steel fittings for worry-free corrosion resistance
- ◆ Can be used with either OPW 2" DPC swage-on or SBC bolt-on double-wall couplings

Light, Flexible & Easy to Install. ULc Approved for Venting with All Fuels

ULc APPROVAL

- ✓ Motor Vehicle Fuels
- ✓ High Blend Fuels
- ✓ Concentrated Fuels
- ✓ Aviation and Marine

Ordering Specifications - Sizing Matrix

Double Wall Vent Pipe

Part #	Description	Packaged	
V20-125B	2" Double Wall Vent Pipe	125 ft	Box
V20-250	2" Double Wall Vent Pipe	250 ft	Reel
V20-500	2" Double Wall Vent Pipe	500 ft	Reel
V30-125	3" Double Wall Vent Pipe	125 ft	Reel
V30-250	3" Double Wall Vent Pipe	250 ft	Reel
V30-500	3" Double Wall Vent Pipe	500 ft	Reel



Celebrating More Than 25 Years of Success Through Piping Excellence

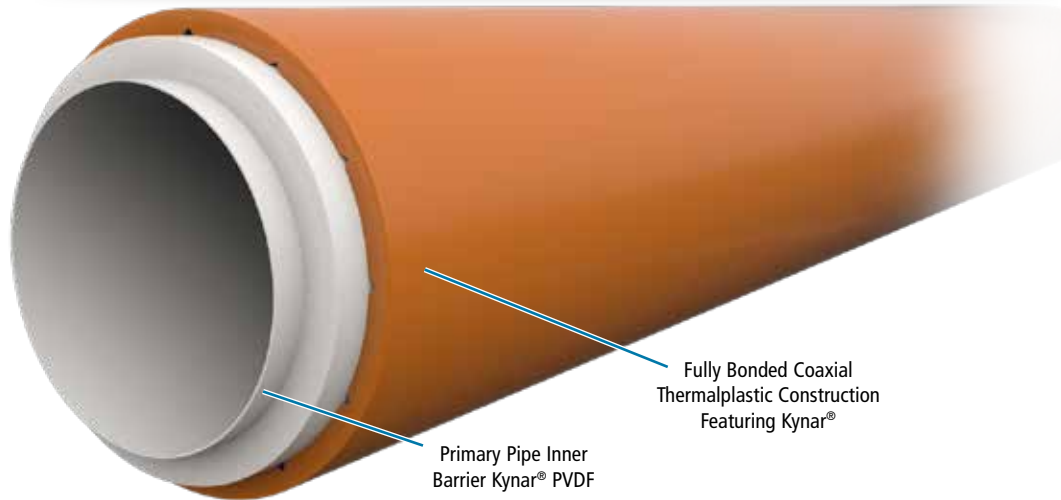

Primary Pipe Inner Barrier Kynar® PVDF

Fully Bonded Coaxial Thermalplastic Construction Featuring Kynar®

What Makes This Pipe Different? Lower installation costs

- ◆ Eliminates the hassles – installation time and potential leak points of rigid pipe installations
- ◆ Fast and easy installation – results in less installation labor, time and cost
- ◆ Eliminates burdensome cutting, fitting, cleaning, gluing or welding
- ◆ No adhesives – heat assists, curing problems or electrofusion welding of joints
- ◆ Easy to bend – no special fittings to install in order to make bends
- ◆ Vent Pipe Kit to seal off interstitial testing port when directly burying DW fittings

Double-Wall Flexible Vent Piping: UL971-Listed, Integral Primary/Secondary, Normal Vent & Vapor Piping, Gasoline, Aviation & Marina Fuels:

A UL-listed, double-wall, flexible supply piping system is designed for installation within access piping (not required but recommended). The outer containment pipe includes inner stand-off ribs to create a small interstitial space which allows for optimum fluid migration, continuous monitoring and easy periodic testing. This piping features an enhanced construction that meets the new UL971 standard. OPW's FlexWorks double-wall piping has both the primary and secondary containment pipe UL-listed and is labeled as follows: INTEGRAL PRIMARY/SECONDARY FOR MOTOR VEHICLE FUELS.

Double-Wall Swivel Pipe Couplings

Double-Wall Swivel Pipe Couplings are a proven coupling and fitting system designed exclusively for use with FlexWorks Piping.

Double-wall swivel couplings and fittings are a double-wall design and are used to interconnect FlexWorks flexible piping. These UL/ULC listed stainless-steel couplings must be contained within containment sumps and not directly buried.

This pipe-connection system includes an internally expanded stainless-steel coupling attached to the end of a FlexWorks pipe section. The swivel coupling has a smooth sealing face fitted with a Viton® ring gasket.

Double-wall swivel couplings eliminate the need for cutting back the secondary jacket and rubber test boots. They have an integral interstitial access port for connector and test tubes.

These double-wall couplings permit higher interstitial testing pressures and eliminate added parts and labor costs.



Double-Wall Pipe Coupling (DPC Model)

Double-wall pipe couplings require the use of an OPW Retail Fueling coupling machine to internally expand the stainless-steel fitting onto the end of a FlexWorks pipe section.

Internally expanded couplings have a long, successful history of reliable performance.

Features & Benefits:

- ◆ UL/ULC listed for use with flex piping
- ◆ Quick, easy to install
- ◆ All stainless-steel couplings
- ◆ Internally expanded couplings
- ◆ Permanent Interstitial Test Port

3" Double-Wall Coupling

- ◆ Fully compatible with our 3" FlexWorks Piping
- ◆ Interstice integrated with the pipe secondary

Ordering Specifications - FlexWorks Double-Wall Swivel Couplings & Fittings

Part #	Application	Weight	Packaging
DPC-2150A	1.5" Double-Wall Swivel Pipe Coupling, Flat Gasket	1.05	EA
DPC-2200A	2" Double-Wall Swivel Pipe Coupling, Flat Gasket	1.35	
DPC-2300A	3" Double-Wall Swivel Pipe Coupling, Flat Gasket	2.35	

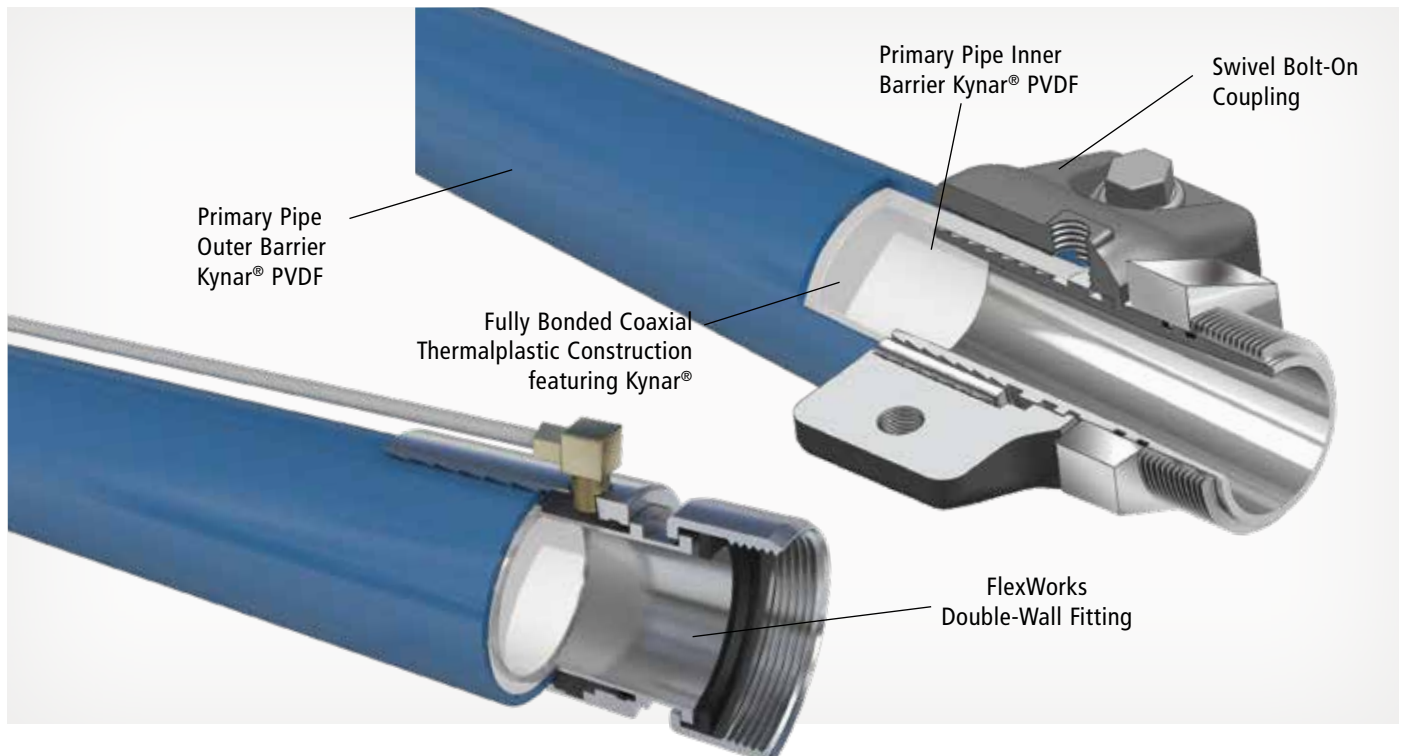



Double-Wall Pipe Coupling (DPC Model)



Adaptor (SMA Model)



Tee (STF Model)



Elbow (SEF Model)

Ordering Specifications* - FlexWorks Swage-On Couplings and Fittings

For single-wall fittings contact customer service at 1-800-422-2525.

Model	Application	Weight/ lbs
DPC-2150A	1.5" Double Wall Swivel Pipe Coupling, Flat Gasket	1.05
DPC-2200A	2" Double Wall Swivel Pipe Coupling, Flat Gasket	1.35
DPC-2300A	3" Double Wall Swivel Pipe Coupling, Flat Gasket	2.35
SFA-7575	3/4" Adaptor, 3/4" Female NPT to 3/4" Female NPT	.35
SMA-7575	3/4" Adaptor, 3/4" Female NPT to 3/4" Male NPT	.50
SFA-1010	1" Adaptor, 1" Female NPT to 1" Female NPT	.60
SMA-1010	1" Adaptor, 1" Male NPT to 1" Female NPT	.55
SMA-1515	1.5" Adaptor, 1.5" NPSH to 1.5" NPT	1.10
SMA-1520	1.5" Adaptor, 1.5" NPSH to 2" Male NPT	1.30
SMA-2020	2" Adaptor, 2" NPSH to 2" Male NPT	1.25
SMA-3030	3" Adaptor, 3" NPSH to 3" NPT	2.50
STF-1515	1.5" Tee, 1.5" NPSH x 1.5" NPSH x 1.5" NPT	2.20
STF-2020	2" Tee, 2" NPSH x 2" NPSH x 2" NPT	4.25
STF-2215	2" Tee, 2" NPSH x 2" NPSH x 1.5" NPT	4.32
STF-3030	3" Tee, 3" NPSH x 3" NPSH x 3" NPT	5.70
STC-0150	1.5" Swivel Test Cap	1.0
STC-0200	2" Swivel Test Cap	1.2
STC-0300	3" Swivel Test Cap	3.65

Model	Application	Weight/ lbs
SEF-1515	1.5" Elbow, 1.5" NPSH x 1.5" NPT	1.50
SEF-2020	2" Elbow, 2" Female NPT to 2" Male NPSH*	2.60
SEF-3030	3" Elbow, 3" NPSH x 3" NPT	4.10
SRE-2015	2" Elbow Reducer, 2" NPSH x 1.5" NPT	2.85
SCC-2015	2" Reducer, 2" NPSH to 1.5" NPSH	3.00
SRT-2151	2" Reducer, 2" NPSH x 1.5" NPSH x 1.5" NPT	3.00
SCC-1515	1.5" Connector, 1.5" NPSH to 1.5" NPSH	0.75
SCC-2020	2" Connector, 2" NPSH to 2" NPSH	1.00
SCC-3030	3" Connector, 3" NPSH to 3" NPSH	1.50
SGP-0150	1.5" Swivel Gasket Pack for DPC-2150A and SPC-0150 (6 ea.)	.10
SGP-0200	2" Swivel Gasket Pack for DPC-2200A and SPC-0200 (6 ea.)	.10
SGP-0300	3" Swivel Gasket Pack for DPC-2300A and SPC-0300 (6 ea.)	.15
SGP-0150FG	1.5" Swivel Gasket Fluorosilicone Pack (6 ea.)	.05
SGP-0200FG	2" Swivel Gasket Fluorosilicone Pack (6 ea.)	.10
VP-KIT	1/8" NPT Stainless-steel Plug (8 ea)	1.00

OPW 21BV Full Port Two-Way Ball Valve

OPW Ball Valves are used throughout fueling systems where a shut-off point is desirable to isolate a section of the piping system. These full-port, forged-brass valves feature a manual open-close arm and a quick quarter-turn handle, allowing easy shut down of your AST or UST system. Compatible with gasoline, alcohol fuels, diesel and MTBE. Available with Lockable Handle (LH).

Ordering Specifications and Dimensions

Model #	Size (in.)	Dimensions (in.)			
		A	B	C	D
21BV-0075	3/4	0.78	2.51	2.36	4.29
21BV-0150	1 1/2	1.57	3.87	2.72	5.63
21BV-0200	2	1.96	4.29	3.03	5.63
21BV-0200SS*	2	1.96	4.80	3.66	7.09
21BV-0300	3	3.15	6.10	5.12	8.35
*SS denotes Stainless-steel.					
202234	Lockable Handle Kit for 3/4" and 1" Models (Handles sold separately)				
202235	Lockable Handle Kit for 1-1/2" and 2" Models (Handles sold separately)				

Listings and Certifications



Materials

Body: Brass
Ball: Hard chrome plated
Seal: Teflon*



Features

- ◆ Pressure rated to 600 psig (41 bar) WOG
- ◆ Blowout-proof stem
- ◆ Chrome-plated brass ball
- ◆ Secondary O-ring stem seal
- ◆ PTFE seats, thrust bearing and stem packing

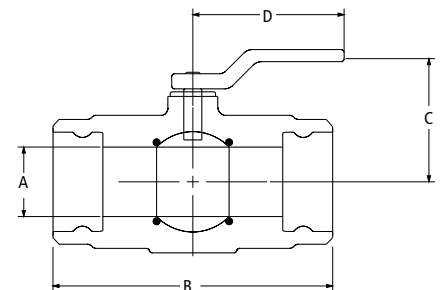

OPW Retail Fueling Introduces a Next Generation of Swivel Bolt-On Couplings

Announcing our revolutionary new SBC Swivel Bolt-On Double-Wall Pipe Coupling. The new patent-pending technology gives users the same great features as our revolutionary DPC swage-on double-wall fittings in a bolt-on design. The SBC eliminates the need to trim back the secondary jacket – and eliminates the need for rubber test boots!

Features and Benefits

- ◆ All Stainless-Steel Wetted Surfaces
- ◆ No Jacket Stripping
- ◆ No Test Boots
- ◆ Male NPT thread allows this coupling to be used with standard plumbing Tees and Elbows
- ◆ Decreased installation time
- ◆ Provides quick and effective means to monitor or retest secondary containment
- ◆ State-of-the-art clamshell interlock design only available through OPW
- ◆ Double O-ring swivel design for easy and secure connections



New patent-pending Swivel Bolt-On Coupling system simplifies the interstitial connection process for FlexWorks Flexible Piping.

Our new FlexWorks Swivel Bolt-On Coupling features permanent access to the pipe's interstice allowing for future integrity testing or continuous interstitial monitoring. Swivel Bolt-On Couplings have an integral interstitial fluid path and a threaded access port located directly on

the coupling collar. This state-of-the-art method of connection is a cost-effective solution that allows rapid system integrity testing as well as interstitial monitoring capability, at installation and in the future to accommodate new monitoring regulations.

Ordering Specifications Swivel Bolt-On Coupling

Model	Description
SBC-2075	Swivel Bolt-On Coupling, 3/4" NPT
SBC-2100	Swivel Bolt-On Coupling, 1" NPT
SBC-2150	Swivel Bolt-On Coupling, 1.5" NPT
SBC-2200	Swivel Bolt-On Coupling, 2" NPT

Ordering Specifications Replacement Gasket Kits

Model	Description
BGP-2075	3/4" Pack of (6) incl. pads & O-rings
BGP-2100	1" Pack of (6) incl. pads & O-rings
BGP-2150	1.5" Pack of (6) incl. pads & O-rings
BGP-220	2" Pack of (6) incl. pads & O-rings

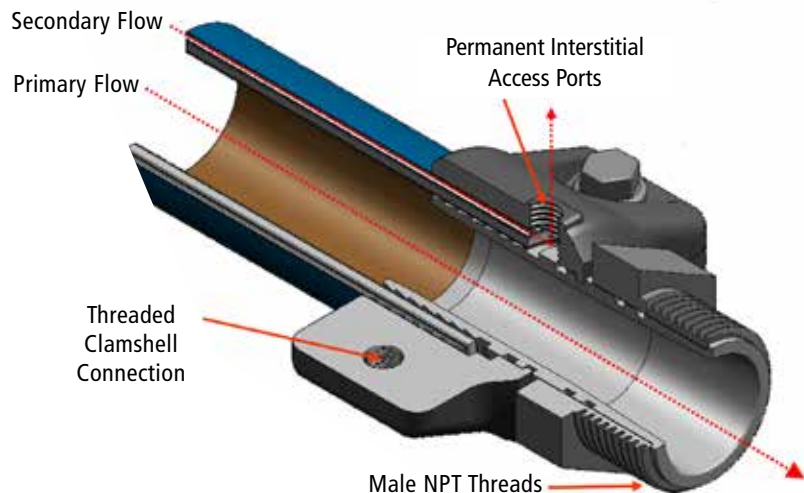

Installation Tools Coupling Machines

The OPW Coupling Machine is required for the installation of both coax and swivel pipe couplings. The Coupling Machine is designed to internally expand the metal pipe insert installed at the end of a pipe section. Coupling machines are available in both 110- and 220-volt models. Coupling swage kits are available to couple both coax and swivel couplings for a variety of pipe sizes.

***IMPORTANT:** When coupling 3/4" and 1" pipe, use the faceplate for the CSK-0150S swage kit as a base for the CSK-0075S and the CSK-0100S swage kits.

Manual, Pneumatic and Electronic Coupling Machines

The OPW Manual, Pneumatic and Electronic Coupling Machines can couple stainless-steel (SSPFC), Swivel (SPC) and Double-Wall (DPC) fittings for 1.5" and 2" only. Swage kits are required.

Ordering Specifications Coupling Machine

Model	Application
CMM-200	Coupling Machine, Manual
CMP-200	Coupling Machine, Pneumatic
CME-200	Coupling Machine, Electronic



Swage Kits

Swages are used with the OPW Coupling Machine to internally expand the coupling onto the end of the flexible pipe section. There are a variety of coupling swage kits available to accommodate a variety of coupling types and sizes. NOTE: 3/4" and 1" swage kits adapt to the 1-1/2" swivel faceplate that comes standard with each coupling machine.

Swage Mandrel	Coupling Paired With:
CMS-0075	PC-0075
CMS-0100-A	SPC-0100
CMS-1500R	DPC-2150A, SPC-0150A
CMS-2000	DPC-2200A, SPC-0200A
CMS-3000	DPC-2300A, SPC-0300A

To be used with OPW Flexworks Piping. For previous generations, call OPW Retail Fueling customer service.

Ordering Specifications - Swage Kit

Fitting Type & Model #	Coupling Machine Model				
	CME-200	CMM-200	CMP-200	CME-0110/0110R	CME-0220
3/4" Swivel (SPC-0075)	SBA2-075	SBA2-075	SBA2-075	CSK-0075S	CSK-0075S
1" Swivel (SPC-0100)*	SBA2-100	SBA2-100	SBA2-100	CSK-0100S	CSK-0100S
1.5" Swivel (SPC-0150A)	SBA2-150	SBA2-150	SBA2-150	CSK-0150S	CSK-0150S
1.5" DW Swivel (DPC-2150A)	SBA2-150	SBA2-150	SBA2-150	CSK-0150S	CSK-0150S
2" Swivel (SPC-0200A)	SBA2-200	SBA2-200	SBA2-200	CSK-0200S	CSK-0200S
2" DW Swivel (DPC-2200A)	SBA2-200	SBA2-200	SBA2-200	CSK-0200S	CSK-0200S
3" Swivel (SPC-0300A)	SBA2-300	N/A	N/A	CSK-0300S	CSK-0300S
3" DW Swivel (DPC-2300A)	SBA2-300	N/A	N/A	CSK-0300S	CSK-0300S

Pipe Cutters

The FlexWorks pipe cutter is designed to produce a clean and even pipe cut, which is necessary for proper coupling attachment. This is required for installation of swivel pipe couplings.

The PCT 2000 makes it easy to cut through OPW FlexWorks pipe up to 2" with a clean, professional-quality finish. The Teflon®-coated hardened steel blade makes clean, burr-free cuts repeatedly, and the spring-loaded ergonomic handle provides a comfortable grip for extended use.

NOTE: When using double-wall pipe couplings, do not trim piping secondary.

Ordering Specifications- Pipe Cutter

Model #	Application
PCT-2000	3/4", 1", 1.5", 2"
PCT-3000	3" Pipe Cutter



PCT-2000 replaces legacy PCT-1000 cutter.

OPW recommends using a ratchet cutter for pipe sizes 3/4", 1", 1.5", 2".

Fishing Bullnose

An attachment for the end of a flexible pipe section, used to aid in fishing the flexible pipe section through the access pipe. There are a variety of bullnoses available to connect to swivel couplings.

NOTE: 3/4" and 1" fishing bullnose are female threaded to accommodate 3/4" or 1" couplings.



Ordering Specifications - Fishing Bullnose

Model #	Application
FBN-2075	3/4" Fishing Bullnose
FBN-2100	1" Fishing Bullnose
FBN-2150	1.5" Fishing Bullnose
FBN-2200	2" Fishing Bullnose
FBN-2300	3" Fishing Bullnose
FBN-3200	2" Bullnose Plug

Barbed Fittings and Adaptors for FlexWorks Primary Pipe

OPW Retail Fueling’s barbed fittings are a single-wall design and are used to connect Flex or Vent piping. This piping-connection system does not require the use of pipe couplings or the OPW Retail Fueling coupling machine. These fittings should be contained within containment sumps or protected in direct-bury applications.

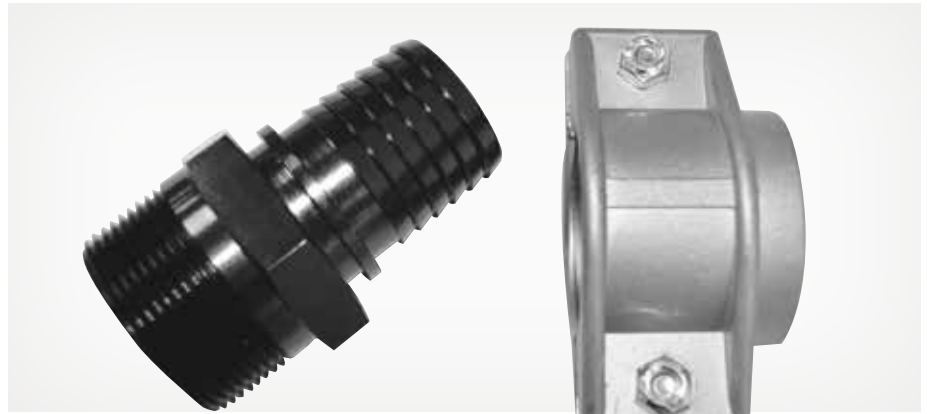

Barbed Male Adaptors

An adaptor is designed to connect one end of a flexible pipe section to a female NPT-threaded coupling or fitting. There is a barbed insert with a clamp assembly on one end and male NPT threads on the other. When used with double-wall FlexWorks piping, it is recommended that a reducer test boot be installed. These adaptors are required to be secondarily contained.

Features and Benefits

- ◆ For use with FlexWorks piping
- ◆ No coupling machine required
- ◆ All stainless-steel clamps
- ◆ Barbs are offset
- ◆ Interlock design

Ordering Specifications

Part #	Description
BMA-1515	NPT 1½" to 1½" Flex Pipe Barbed Male Adaptor
BMA-2020	2" Barbed Male Adaptor
BMA-3030	3" Barbed Male Adaptor

Urethane Sealant

An all-purpose sealant. Can be used as an entry fitting sealant as well as to bond dispenser tops.

Ordering Specifications - Urethane Sealant

Model #	Application
SL-1100	Urethane Sealant (10.3 oz. Cartridge)

OPW Offers a Variety of Tank Sump Models Made From Both Polyethylene and Fiberglass

OPW tank sumps function as a liquid-tight isolation container providing secondary containment for the tank fittings, valves, pumps and FlexWorks pipe fittings.

They also provide surface access to the tank itself, as well as a clean, dry environment for future service and maintenance. All tank sump models have height-adjustable risers to accommodate different tank burial depths. Each sump model has its own specific range of height adjustability and are fabricated and assembled at the job site.

ElectroTite Tank Sump



TSE Tank Sump



FibreTite Tank Sump



Polyethylene Tank Sump with Mechanically Fastened Cover



Tank Sump Manual
Order Number: TSM-0001

ElectroTite Tank Sump

Introducing the latest OPW tank sump innovation from the engineering labs of FlexWorks and Fibrelite. ElectroTite is the most watertight system on the market. It ships factory installed with conduit ports and electrical wiring box – eliminating unnecessary tank sump leak points at site installation. No drill, no water, no sweat.

Materials:

Sump: Resin Transfer Molding (RTM) technology



Uses built-in electrical seal-offs



Features & Benefits:

Watertight:

- ◆ Reduces the number of entry and leak points into sump
- ◆ Sealed conduit threads on outside of sump – enter above water table
- ◆ Factory-installed fitting with proper torque guns, cutting tools and sealing compound

Versatile for Your Installation:

- ◆ UL-listed explosion-proof junction box allows space to re-route communication wires and loop additional sensors without entering sump
- ◆ Shield allows for high-voltage and sensor wires to be separated in the same box
- ◆ Conduits can be potted entering box, exiting box, or both using built-in electrical seal-offs

- ◆ UL-listed explosion-proof box is single-piece cast aluminum, with bolt-on access cover

Factory Installed:

- ◆ Eliminates the need to cut holes in sump for conduits
- ◆ No field-installed conduit penetrations

FXSX - X - XXXXXX

FCS = FibreTite Conduit Sump

M = Medium bury

Only available on FCS

42 = 42" Sump Base Diameter

33 = 33" Sump Lid Diameter (WT-33)

CR = Collar Ring Mount

FTS = FibreTite Tank Sump

D = Deep bury

1 = One ElectroTite Conduit Box

48 = 48" Sump Base Diameter

37 = 37" Sump Lid Diameter (WT-37)

SB = Solid Bottom

2 = Two ElectroTite Conduit Boxes

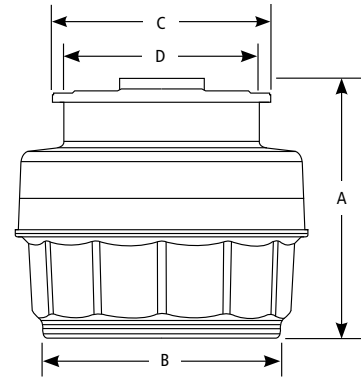

Ordering Specs

Model Number	Maximum Sump Height (A)	Minimum Sump Height (A)	Sump Base Diameter (B)	Sump Mount Design	Sump Lid Diameter (C)	Minimum Diameter Opening (D)	# of Conduit Boxes
FCSM-1-4233CR	46"	39"	42"	Collar Ring Mount	34.8"	29"	Single
FCSM-1-4233SB	46"	39"	42"	Solid Bottom	34.8"	29"	Single
FCSD-1-4233CR	53"	47"	42"	Collar Ring Mount	34.8"	29"	Single
FCSD-1-4233SB	53"	47"	42"	Solid Bottom	34.8"	29"	Single
FCSM-2-4233CR	46"	39"	42"	Collar Ring Mount	34.8"	29"	Dual
FCSM-2-4233SB	46"	39"	42"	Solid Bottom	34.8"	29"	Dual
FCSD-2-4233CR	53"	47"	42"	Collar Ring Mount	34.8"	29"	Dual
FCSD-2-4233SB	53"	47"	42"	Solid Bottom	34.8"	29"	Dual
FCSM-1-4837CR	46"	39"	48"	Collar Ring Mount	39.5"	34.6"	Single
FCSD-1-4837CR	53"	47"	48"	Collar Ring Mount	39.5"	34.6"	Single
FCSM-2-4837CR	46"	39"	48"	Collar Ring Mount	39.5"	34.6"	Dual
FCSD-2-4837CR	53"	47"	48"	Collar Ring Mount	39.5"	34.6"	Dual

Replacement Parts

Part Number	Sump Base Diameter	Part Number	Sump Base Diameter
FTSMBASE-42CR	42" Medium Bury Collar Mount Base	FTS-4233TH	Top Hat for 42" Base Sump (33" opening)
FTSMBASE-42SB	42" Medium Bury Solid Bottom Base	FTS-4237TH	Top Hat for 42" Base Sump (37" opening)
FTSDBASE-42CR	42" Deep Bury Solid Collar Mount Base	FTS-4837TH	Top Hat for 48" Base Sump (37" opening)
FTSDBASE-42SB	42" Deep Bury Solid Bottom Base	WT-33SL	33" Fibretite Sump Lid
FTSMBASE-48SB	48" Medium Bury Solid Base	WT-37SL	37" Fibretite Sump Lid
FTSMBASE-48CR	48" Medium Bury Collar Mount	FCS42-EX12	42" Diameter Sump 12" Extension
FTSDBASE-48CR	48" Deep Bury Collar Mount	FCS48-EX12	48" Diameter Sump 12" Extension

FibreTite Tank Sump

From the engineering labs of Flexworks and Fibrelite, OPW has made the best even better. Meet the newest member of the FibreTite Family of sumps, the most watertight sumps on the market today. Designed to meet all the new 2018 EPA UST regulations.

Features & Benefits:

- ◆ The only sump manufactured using superior Resin Transfer Molding (RTM) technology. The RTM process utilizes a two-sided mold to ensure consistent wall thickness and exceptionally smooth wall surfaces inside and out for an ultra-tight entry fitting sealing surface
- ◆ Two-piece top-hat design allows for tailored height adjustments

Materials:

Sump: Resin Transfer Molding (RTM) technology



- ◆ Inverted U-Channel allows for equal resin distribution, creating a superior bond between the base and the top hat to eliminate water intrusion
- ◆ Stainless-steel ring and watertight sealing gasket provide the proven seal-ability of our world-renowned Fibrelite sumps
- ◆ Available with and without bottom for collar or flange mounting
- ◆ Ergonomic "L-Handle" provides ease of use and a visual indicator that the handle is in the locked position and the watertight lid is secure

Ordering Specifications - Tank Sump Systems

	New Name	Max Sump Height (A)	Min Sump Height (A)	Sump Base Diameter (B)	Sump Mount Design	Sump Lid Diameter (C)	Minimum Diameter Opening (D)	Additional RK-5000 Resin Kits Needed for Top Hat Attachment (Sold Separately)	Additional RK-5000 Resin Kits Needed for Collar Ring Attachment (Sold Separately)
42"	FTSM-4233CR	46"	33.5"	42"	Collar Ring Mount	34.8"	29"	1	1
	FTSM-4233SB	46"	33.5"	42"	Solid Bottom	34.8"	29"	1	-
	FTSD-4233CR	53"	40.5"	42"	Collar Ring Mount	34.8"	29"	1	1
	FTSD-4233SB	53"	40.5"	42"	Solid Bottom	34.8"	29"	1	-
	FTSM-4237CR	46"	33.5"	42"	Collar Ring Mount	39.5"	34.6"	1	1
	FTSM-4237SB	46"	33.5"	42"	Solid Bottom	39.5"	34.6"	1	-
	FTSD-4237CR	53"	40.5"	42"	Collar Ring Mount	39.5"	34.6"	1	1
	FTSD-4237SB	53"	40.5"	42"	Solid Bottom	39.5"	34.6"	1	-
48"	FTSM-4837CR	46"	33.5"	48"	Collar Ring Mount	39.5"	34.6"	1.5	1
	FTSD-4837CR	53"	40.5"	48"	Collar Ring Mount	39.5"	34.6"	1.5	1
	FTSM-4837SB	46"	33.5"	48"	Solid Bottom	39.5"	34.6"	1.5	-
	FTSD-4837SB	53"	40.5"	48"	Solid Bottom	39.5"	34.6"	1.5	-

Replacement Parts/Accessories

Part #	Description
FTSMBASE-42CR	42" Medium Bury Collar Mount
FTSMBASE-42SB	42" Medium Bury Solid Bottom
FTSMBASE-48SB	48" Medium Bury Solid Bottom
FTSMBASE-48CR	48" Medium Bury Collar Mount
FTSDBASE-42CR	42" Deep Bury Medium Bury Collar
FTSDBASE-42SB	42" Deep Bury Solid Bottom
FTSDBASE-42SB	48" Medium Bury Solid Bottom
FTSDBASE-48CR	48" Deep Bury Collar Mount
FTS-4233TH	Top Hat for 42" Base Sump (33" opening)
FTS-4237TH	Top Hat for 42" Base Sump (37" opening)
FTS-4837TH	Top Hat for 48" Base Sump (37" opening)

Part #	Description
WT-33SL	33" Fibretite Sump Lid
WT-37SL	37" Fibretite Sump Lid
FCS42-EX12	42" Diameter Sump 12" Extension (1 RK-5000 kit needed for attachment sold separately)
FCS48-EX12	48" Diameter Sump 12" Extension (1.5 RK-5000 kit needed for attachment sold separately)
RK-5000	1 Quart Epoxy Resin Kit
S-CR-FGK	Optional Glassing Kit for Collar Ring Attachment

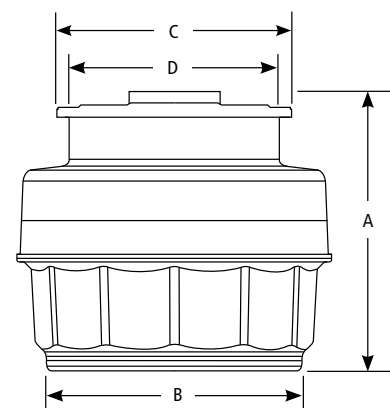

TSE Tank Sump

Using the same innovative Advanced Composite Technology as the DSE, OPW is proud to introduce the TSE Tank Sump.

The industry's first all fiberglass/composite containment system utilizing sheet molded compounds (SMC) to create a high-quality solution that quickly creates cost-effective peace of mind for retail petroleum operators.

Smooth Sides, Inside and Out

As the only manufacturer in the industry using Advanced Composite Technology, OPW's E-Series are the only fiberglass sumps with smooth walls on the inside and outside of the sump. Smooth sides bond better to prevent leaks and other maintenance needs.

Materials:

- Body:** Fiberglass
- Cover/Lid:** Fiberglass
- Water Tight Seal:** Stainless-Steel/Nitrile
- Compression Seal:** Nitrile



Features & Benefits:

- ◆ The shortest lead times of any fiberglass sumps in the industry
- ◆ Consistent thickness and smooth surfaces for a watertight seal
- ◆ Built with legendary OPW quality, service, support and value
- ◆ Value-priced to compete against any fiberglass sumps on the market

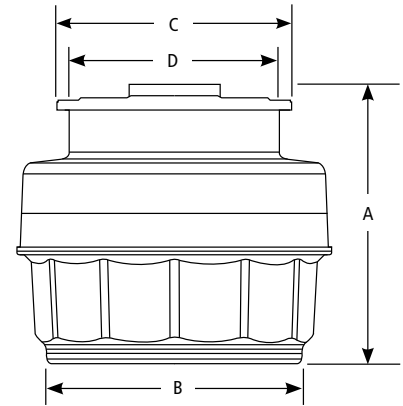

Ordering Specifications - TSE Tank Sumps

Part Number	Sump Mount Design	Cover Style	A		B	C	D	Additional RK-5000 Resin Kits Needed for Top Hat Attachment (Sold Separately)	Additional RK-5000 Resin Kits Needed for Collar Ring Attachment (Sold Separately)
			Maximum Sump Height	Minimum Sump Height	Sump Base Diameter	Sump Lid Diameter	Minimum Diameter Opening		
TSE-4233CR*	Collar Ring	Compression	43"	30"	42"	34"	33"	1	1
TSE-4233SB*	Solid Bottom	Compression	43"	30"	42"	34"	33"	1	-
TSE-4233CR-WT	Collar Ring	Locking L Handles	45"	33.5"	42"	34"	29"	1	1
TSE-4233SB-WT	Solid Bottom	Locking L Handles	46"	33.5"	42"	34"	29"	1	-

*For Compression Style TSE Lids, (1) tube of SL-1100 is recommended for installation of seal.

Replacement Parts/Accessories

Part #	Description
TSEBASE-42CR	TSE 42" Medium Bury Collar Mount
TSEBASE-42SB	TSE 42" Medium Bury Solid Bottom
TSE-4233TH*	TSE Top Hat Compression Style
TSE-4233TH-WT	TSE Top Hat SS Ring - Locking L Handle
TSE-LID	TSE Lid - Compression Style
4233-TH	TSE Lid - Locking L Handle
TSE-SEAL	TSE Seal Kit for TSE-4233CR and TSE-4233SB
216662	TSE Lid Center Handle (Used on TSE-LID and WT-33SL)
210474	TSE Lid Center Handle Screws (2 required)

*For Compression Style TSE Lids, (1) tube of SL-1100 is recommended for installation of seal.



Listings and Certifications



Polyethylene Tank Sumps with Mechanically Fastened Covers

Features & Benefits:

- ◆ **Long-Term Watertight Performance/Strength & Rigidity** – one-piece design provides reliable watertight integrity and long product life. Designed to resist deformation under burial and high water-table forces
- ◆ **Installation Flexibility** – multiple flats provide maximum area for locating pipe entries
- ◆ **Easy Field Height Adjustability** – the special ribbed height adjustment design makes adjustments to finished grade, if necessary, quick and easy

Replacement Parts and Accessories

Part #	Description
H13257M	Knob (each)
H13971	Knob Kit (6 Pack)
H13213M	Bracket
H13214M	Seal 33" (838 mm)
H13215M	Seal 39" (991 mm)
C04420M	Ring 33" (838 mm)
C04432M	Ring 39" (991 mm)
D02025M	Cover 33" (838 mm)
D02034M	Cover 39" (991 mm)
CLC-33	Latched Fiberglass Tank Sump Lid

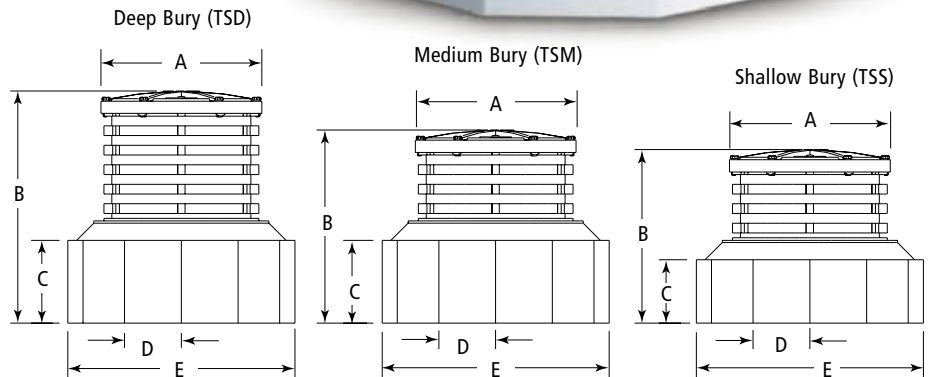

Ordering Specifications for New Latched Fiberglass Tank Sump Lids

Part #	Description
CLC-33	Latched Fiberglass Tank Sump Lid
LRK-CLC	Latch Replacement Kit for the CLC-33

Ordering Specifications - Polyethylene Tank Sumps (with Mechanically Fastened Covers)

Part #	Application	Dimensions										Weight			
		Manway Dia.		A Cover		B Height		C x D Panel		No. of Panels	E Base		lbs.	kg	
in.	mm	in.	mm	in.	mm	in.	mm	in.	mm		in.	mm			
TSS-4536	Tank Sump Shallow Bury, 36" x 45"	36	914	33	838	34	864	12 x 12	305 x 305	12	45	1,143	84	38	
TSM-4536	Tank Sump Medium Bury, 36" x 45"	36	914	33	838	39	991	17 x 12	432 x 305	12	45	1,143	86	39	
TSM-4842	Tank Sump Medium Bury, 42" x 48"	42	1,067	39	991	39	991	17 x 11	423 x 279	14	48	1,219	88	40	
TSD-4536	Tank Sump Deep Bury, 36" x 45"	36	914	33	838	51	1,295	17 x 11	423 x 279	14	48	1,219	90	41	
TSD-4842	Tank Sump Deep Bury, 42" x 48"	42	1,067	39	991	51	1,295	17 x 11	432 x 279	14	48	1,219	92	42	

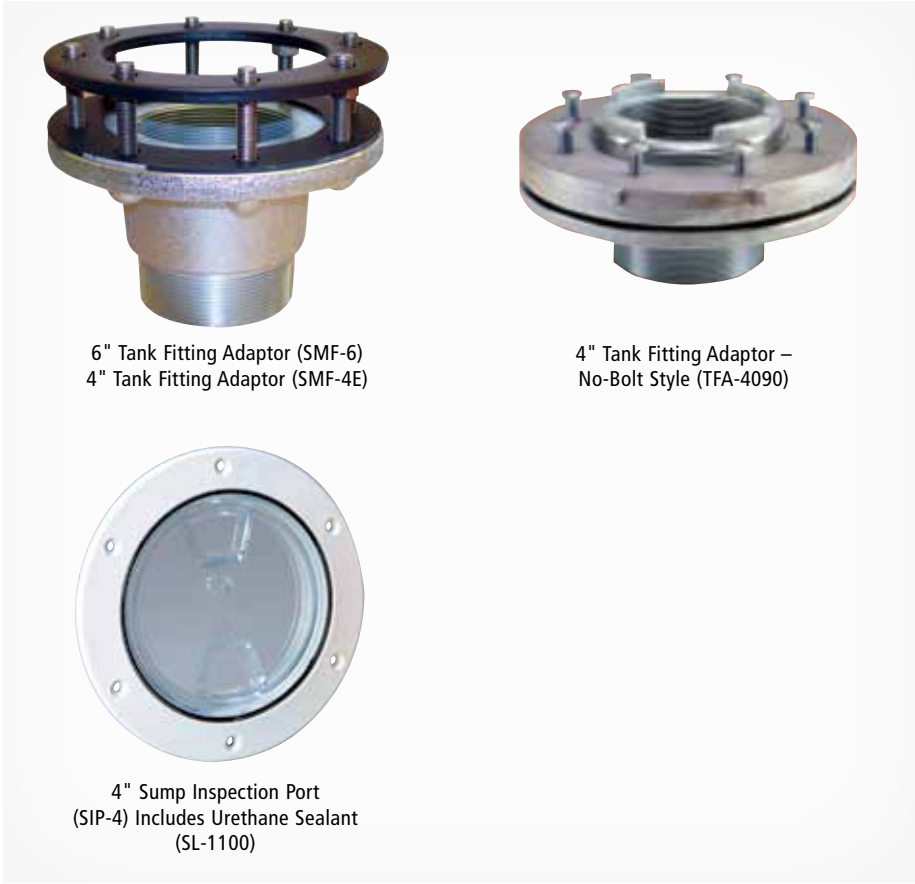

6" Tank Fitting Adaptor (SMF-6)
4" Tank Fitting Adaptor (SMF-4E)

4" Tank Fitting Adaptor –
No-Bolt Style (TFA-4090)

4" Sump Inspection Port
(SIP-4) Includes Urethane Sealant
(SL-1100)

Tank Sump-Mounting Flanges

FlexWorks tank sump-mounting flanges are used to mount FlexWorks tank sumps to 4" and 6" underground storage tank bung fittings. Flange top models (SMF-6) provide added flexibility in positioning of pump or extractor outlets. First, the riser or extractor is threaded into the top flange. The top flange is then oriented and bolted to the mounting flange.

Our no-bolt style mounting flange, model TFA-4090, is also used to mount FlexWorks tank sumps to 4" underground storage tank bung fittings and attaches to the bottom of the sump base to provide a secure and liquid-tight connection. This model has compression studs for added stability and fast and easy installation with a socket wrench.

Sump Inspection Ports

FlexWorks optional sight-glass kits include urethane sealant (SL-1100).

Ordering Specifications - Tank Fitting Adaptor

Part #	Application
TFA-4090	4" Tank Fitting Adaptor, No Bolt Style
SMF-4E	4" Tank Fitting Adaptor, Bolt Style
SMF-4EFT	4" Tank Fitting Adaptor, Bolt Style, Extended Flange
SMF-6	6" Tank Fitting Adaptor, Bolt Style

Ordering Specifications - Sump Inspection Port

Part #	Application
SIP-4	4" Sump Inspection Port
SIP-6	6" Sump Inspection Port

S Series, Fibrelite and FlexWorks Replacement Parts

Ordering Specifications - Sump Accessories and Lids



Part #	Application	Dia.	Weight (lbs)
WSP-WTS-OPC	6" Nitrile Observation Port Cap for WSP		
WS-RING-33	33" Stainless-steel Retaining Ring for Top-Hat		
WS-RING-37	37" Stainless-steel Retaining Ring for Top-Hat		
WTS-LHANDLE	L Style Replacement Sump Lid Handle		
WTS-THANDLE	T Style Replacement Sump Lid Handle		
WT-33	34.6" Dia. Watertight, Structural Spill Platform	34.6"	13
WT-37	38.4" Dia. Watertight, Structural Spill Platform	38.4"	17

The Loop System contains fewer parts to stock and install



ABOVEGROUND MAINTENANCE, ABOVE & BEYOND PERFORMANCE



**ELECTROTITE
TANK SUMPS**



**DUAL-LAYER
ACCESS PIPES**



**UL 971-LISTED
COAXIAL PIPES**



**DUAL-SIDED RIGID
ENTRY FITTINGS**



**DOUBLE-WALL PIPE
COUPLINGS (DPC)**



**10 PLUS
EMERGENCY
VALVES**



**PRE-FABRICATED
QUICK-COUPLE
DISPENSER SUMPS**



**HIFLO DISPENSER
SUMPS**

The Loop System™ Ordering Guide



Loop System Dispenser Sumps are shipped complete with factory-installed pipe entry fittings, OPW 10 Plus Shear Valves, and Stabilizer Bars. Each Dispenser Sump has been assigned a custom Sump Configuration Number based on the number and position of pipe entries into the sump. Each Sump Product Number reflects this configuration number as well as materials used and for the application needed. The guide below explains the Product Number in detail.



Benefits

- 50% Faster Installation Times
- 100% Accessible No Breaking Concrete
- Double Containment Protection
- Completely Testable
- End-to-End Monitoring
- Fewer Parts to Stock and Install

For high-flow applications, see HiFlo Ordering Guide on page 28.

Ordering Guide

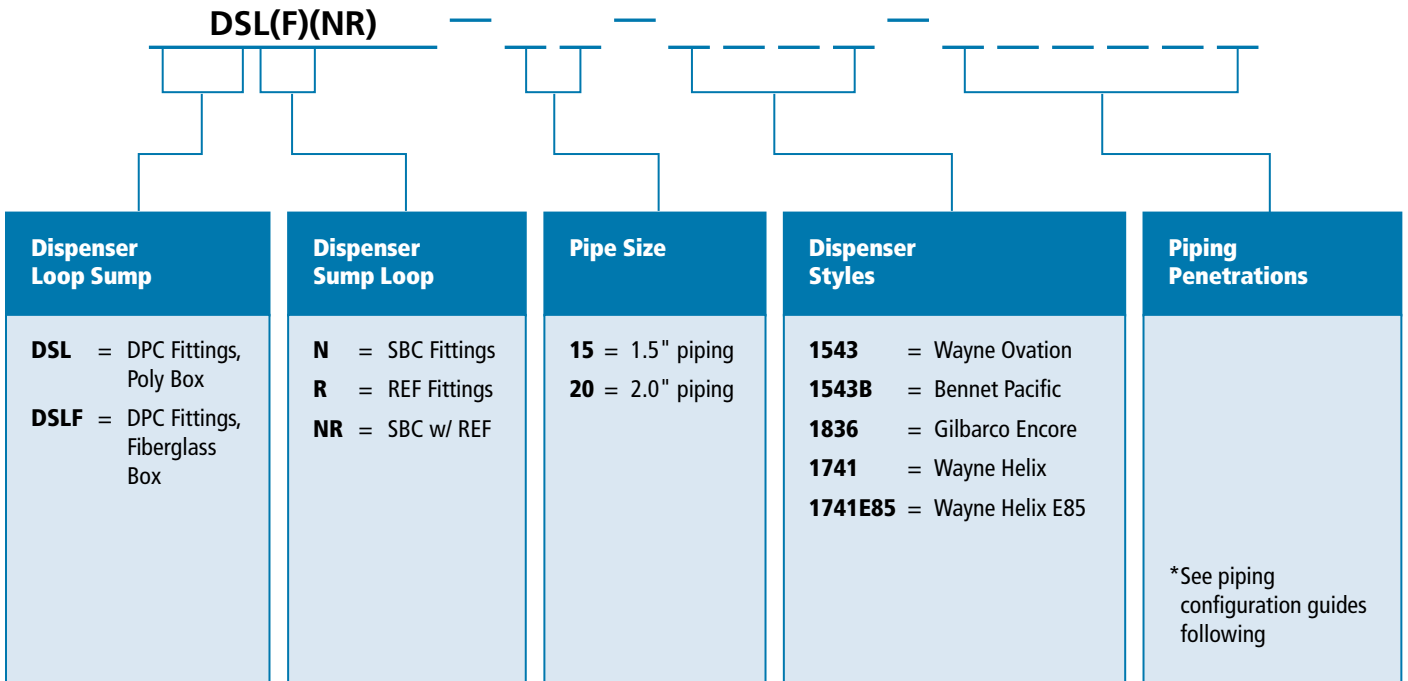

The Loop System™ Ordering Guide



Forecourt Examples

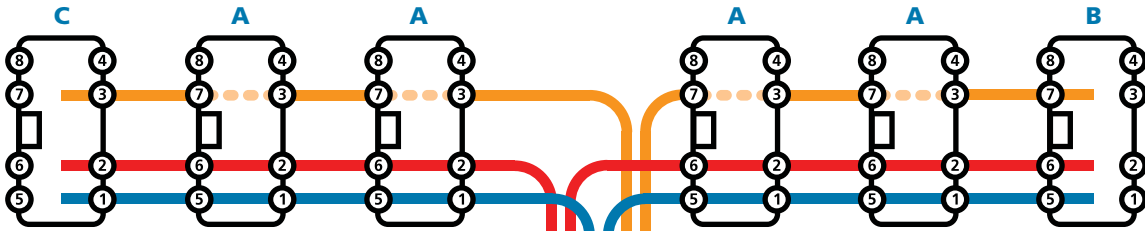

●●●●●
 Dashed line represents the pipe does not go through the sump but underneath it.

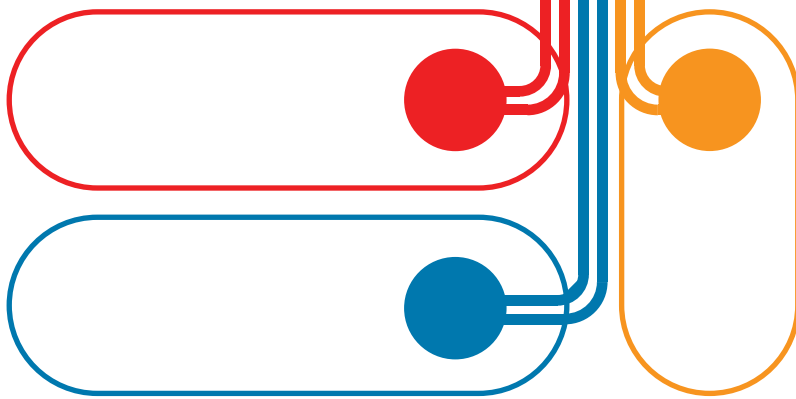

Example 1

This layout shows three different sump configurations:

- (A) DSL-15-1836-1256**
- (B) DSL-15-1836-567**
- (C) DSL-15-1836-123**

NOTES

- Poly sumps (DSL in the part number)
- DEB entry fittings (DSL in the part number)
- 1.5" pipe (-15- in the part number)
- These are Gilbarco Encore dispensers (-1836- in the part number)
- The two 3+1 dispensers have different configurations, B and C

CONTACT CUSTOMER SERVICE FOR CUSTOM CONFIGURATIONS

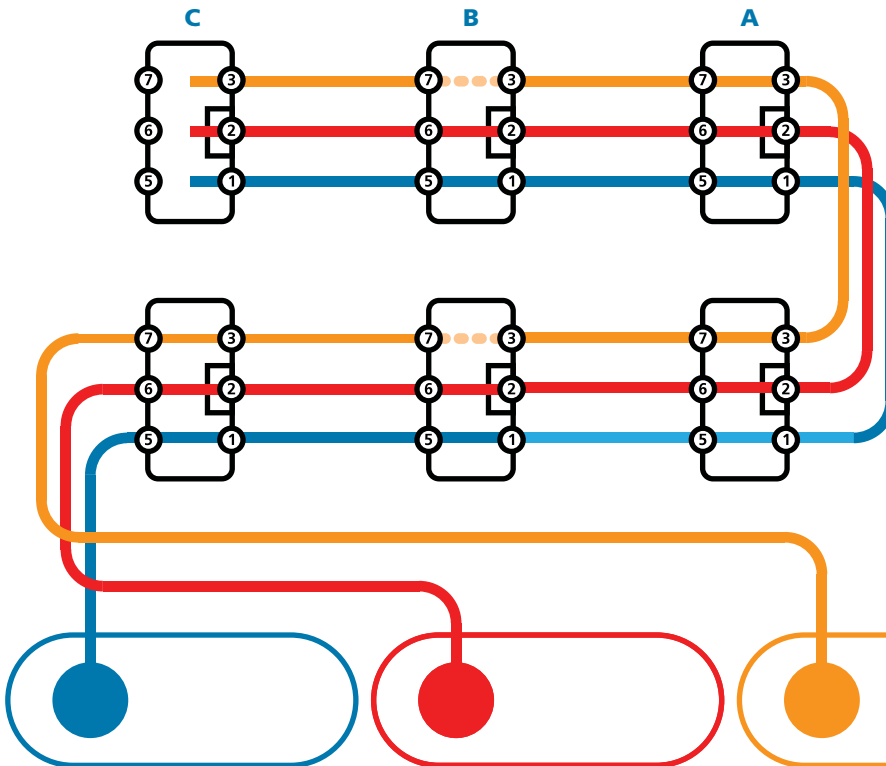

Example 2

This layout shows three different sump configurations:

- (A) DSLFR-15-1543-123567**
- (B) DSLFR-15-1543-1256**
- (C) DSLFR-15-1543-123**

NOTES

- Fiberglass sumps (DSLFR in the part number)
- REF entry fittings (DSLFR in the part number)
- 2.0" pipe (-20- in the part number)
- These are Wayne Ovation dispensers (-1543- in the part number)
- The product lines cross in order to keep the dispenser "Side A" consistent

CONTACT CUSTOMER SERVICE FOR CUSTOM CONFIGURATIONS

TOP VIEW OF BASES

The Loop System™ Ordering Guide



Gilbarco Encore

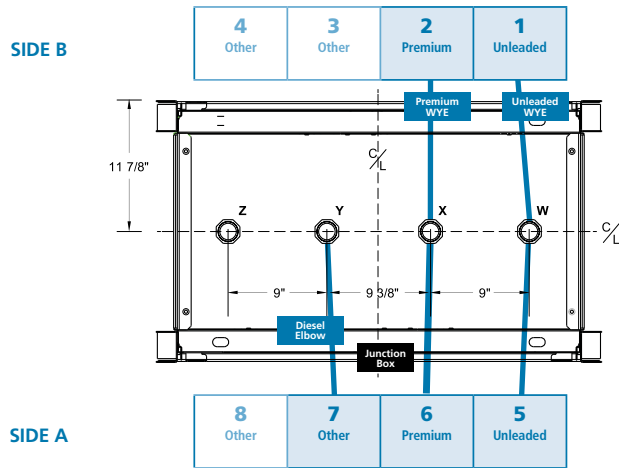

Wayne Ovation

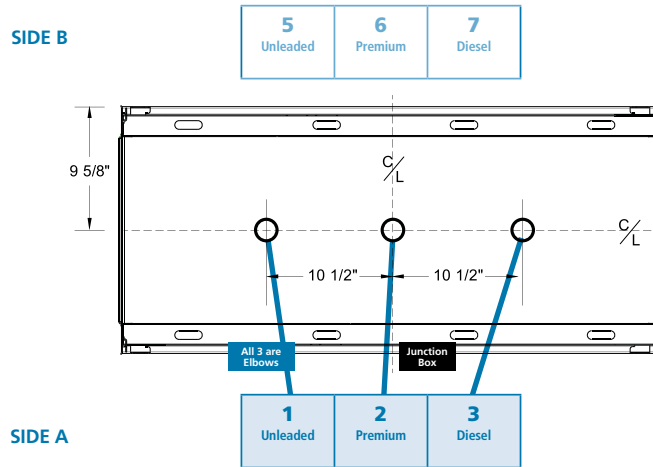

Wayne Four Product

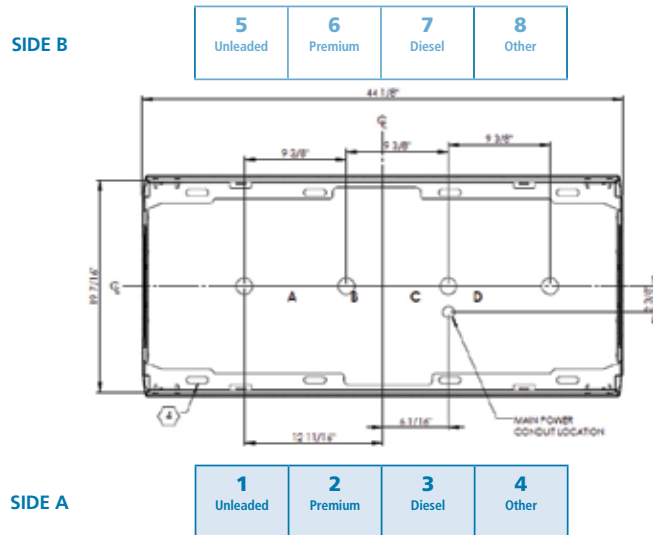

TOP VIEW OF BASES

The Loop System™ Ordering Guide



Wayne Helix

SIDE B

4 Other	3 Other	2 Premium	1 Unleaded
-------------------	-------------------	---------------------	----------------------

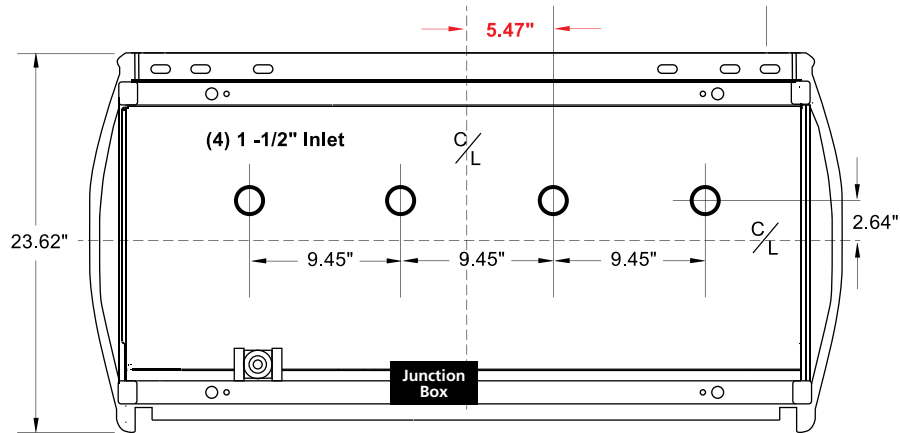

SIDE A

8 Other	7 Other	6 Premium	5 Unleaded
-------------------	-------------------	---------------------	----------------------

Wayne Helix E85

SIDE B

4 Other	3 Other	2 Premium	1 Unleaded
-------------------	-------------------	---------------------	----------------------

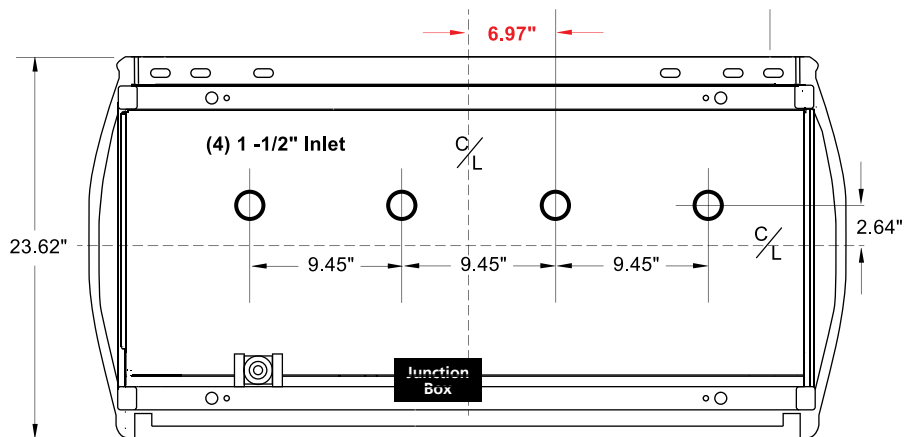

SIDE A

8 Other	7 Other	6 Premium	5 Unleaded
-------------------	-------------------	---------------------	----------------------

TOP VIEW OF BASES

The Loop System™ Ordering Guide



The patented OPW HiFlo Loop System™ represents the state of the art in Retail Fueling containment technology offering a completely integrated, environmentally secure underground fuel-delivery system. By design, the system employs pre-fabricated and factory-assembled components resulting in dramatically less field labor, lower associated costs, and reduced potential for installation errors. The installed product preserves complete underground access to all piping connections, piping runs, and containment sumps. This unprecedented level of access allows for hassle-free inspections and maintenance without ever having to disrupt the business of the site with excavation. The HiFlo Loop System incorporates field-proven OPW technology to provide the same peace-of-mind that customers have come to expect from the traditional Retail Loop System.



Benefits

- **Compatible with Ovation and Encore High-Speed Dispensers**
- **Configurable for any Master->Satellite setup**
- **New 2" 10 Plus provides best-in-class flow and protection**
- **New Hybrid Entry Fitting (HEF) combines the benefits of REF outside the sump with the flexibility of DEB on the inner sump**
- **The OPW HiFlo Loop System™** – Providing a radically new solution to minimize traditional fuel-delivery system problems.
- **The End Result** – An exponentially higher level of environmental protection and lower cost of fuel-delivery system ownership.

Ordering Guide

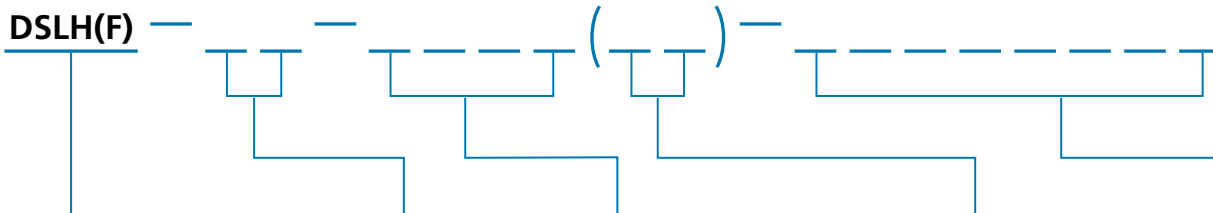

Dispenser Sump Loop, HiFlo	Trunk Line Size	Dispenser Style	Ovation Options (As Needed)	Configuration Layout
<p>DSLH = Poly, DPC Fittings</p> <p>DSLHF = Fiberglass, DPC Fittings</p> <p>DSLHN* = Poly, SBC Fittings</p> <p>DSLHFN* = Fiberglass, SBC Fittings</p> <p>*Only available for 2" trunk lines</p>	<p>20 = 2" Trunk</p> <p>30 = 3" Trunk</p> <p>23 = 2" x 3" Trunk*</p> <p>32 = 3" x 2" Trunk*</p> <p>XX = No Trunk, Satellite Dispenser</p> <p>*First number indicates Side A, Second number indicates Side B</p>	<p>1535L = Ovation HS, DEF Left</p> <p>1535R = Ovation HS, DEF Right</p> <p>1543 = Ovation HS</p> <p>1836 = Gilbarco Encore</p> <p>1836M = Gilbarco Encore Master</p>	<p>D = Dual Master</p> <p>T = With Strainer</p>	<p>See footprint charts</p>

TOP VIEW OF BASES

The HiFlo Loop System™ Ordering Guide



Encore Ultra-High Master (1836M)

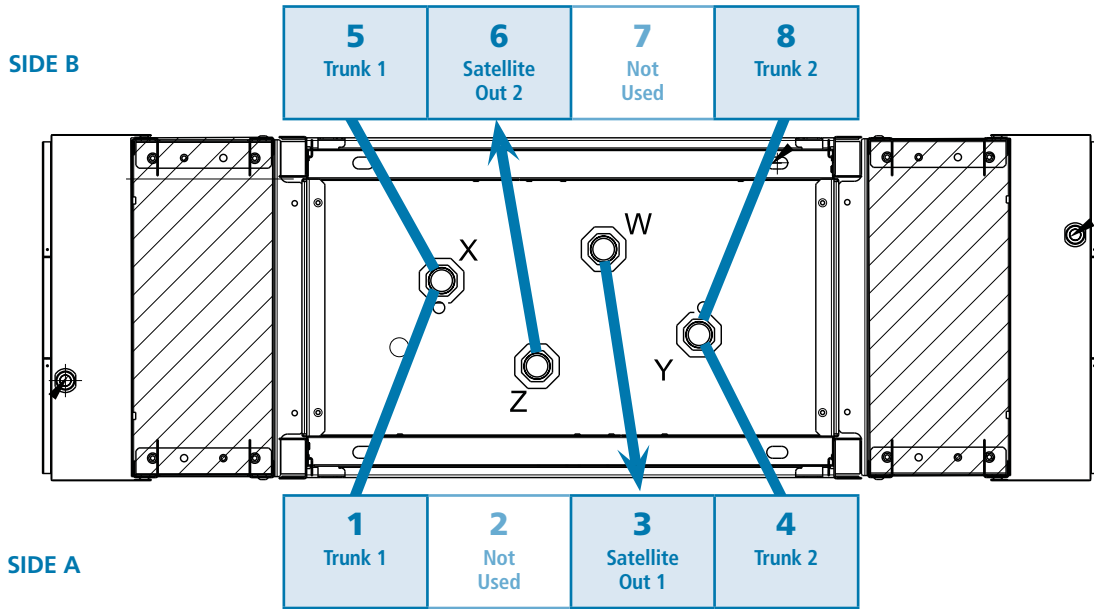

Encore Ultra-High, Single-Sided Master (1836M)

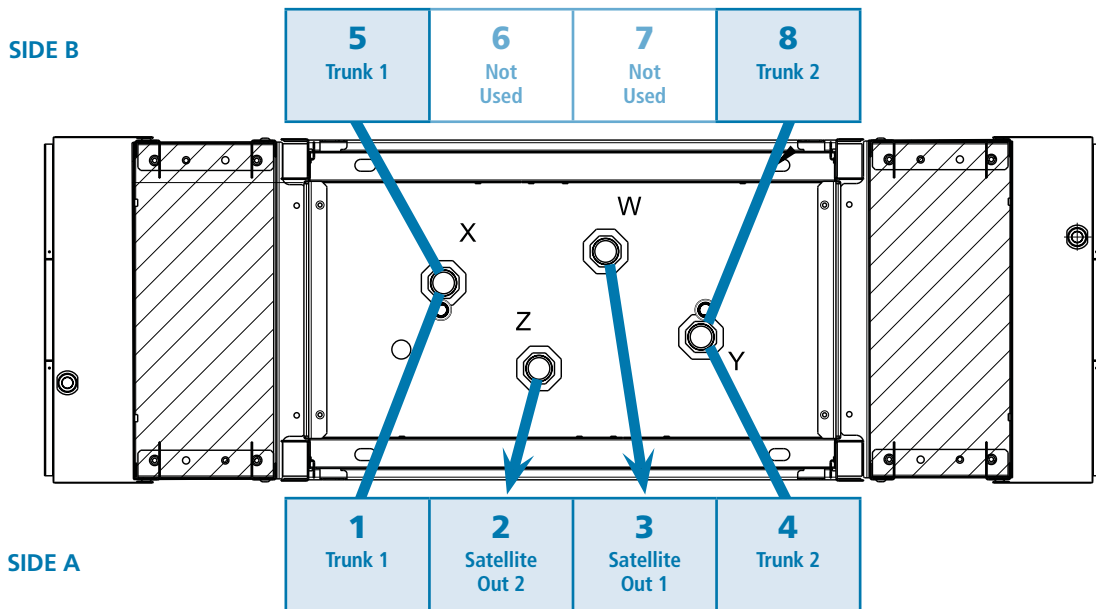

TOP VIEW OF BASES

The HiFlo Loop System™ Ordering Guide



Encore Ultra-High Master/Satellite

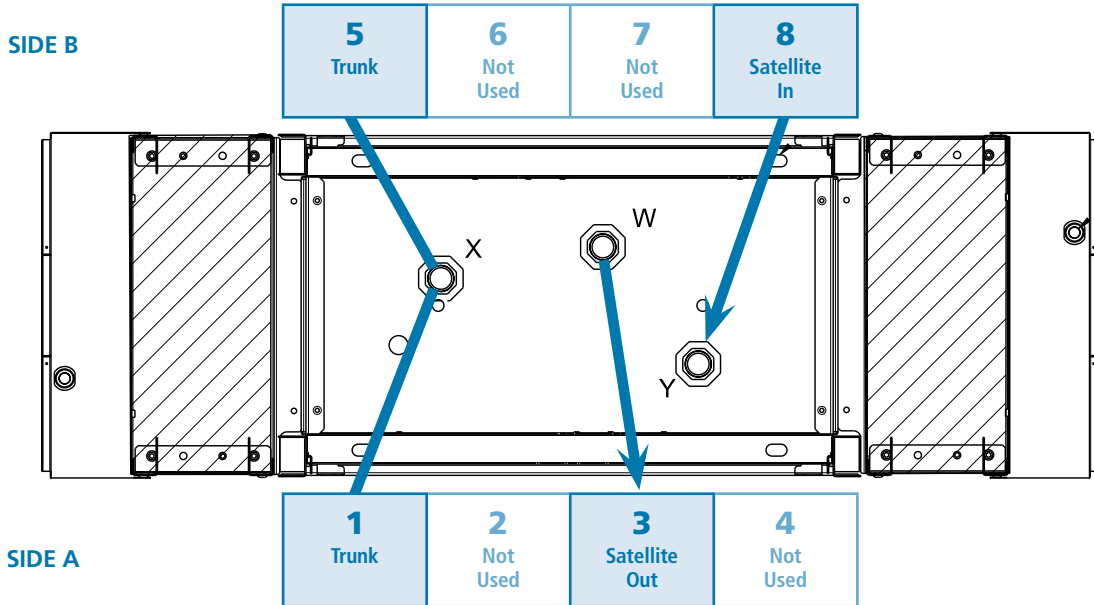

Encore Ultra-High Satellite

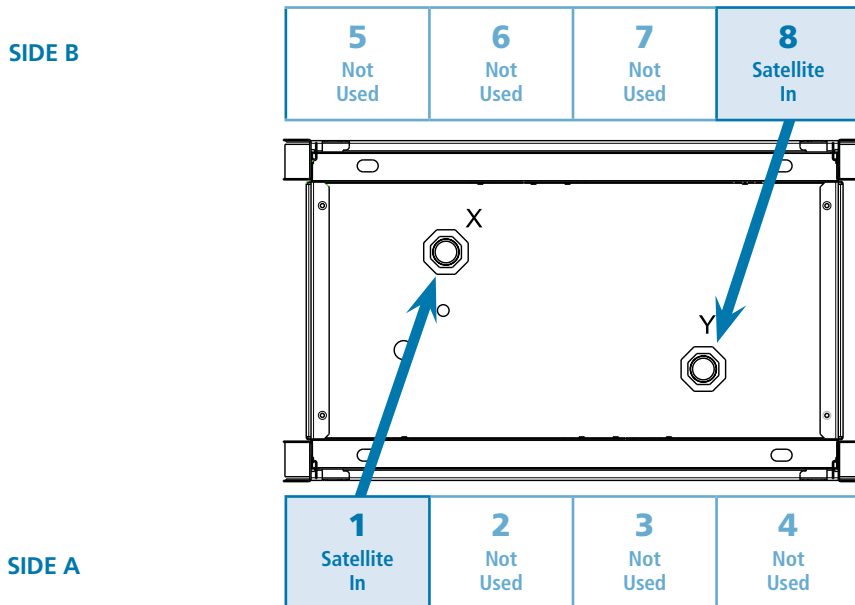

Note: For single-sided satellites, use position "1" on Side A.

TOP VIEW OF BASES

The HiFlo Loop System™ Ordering Guide

Wayne Ovation HS, Single Master

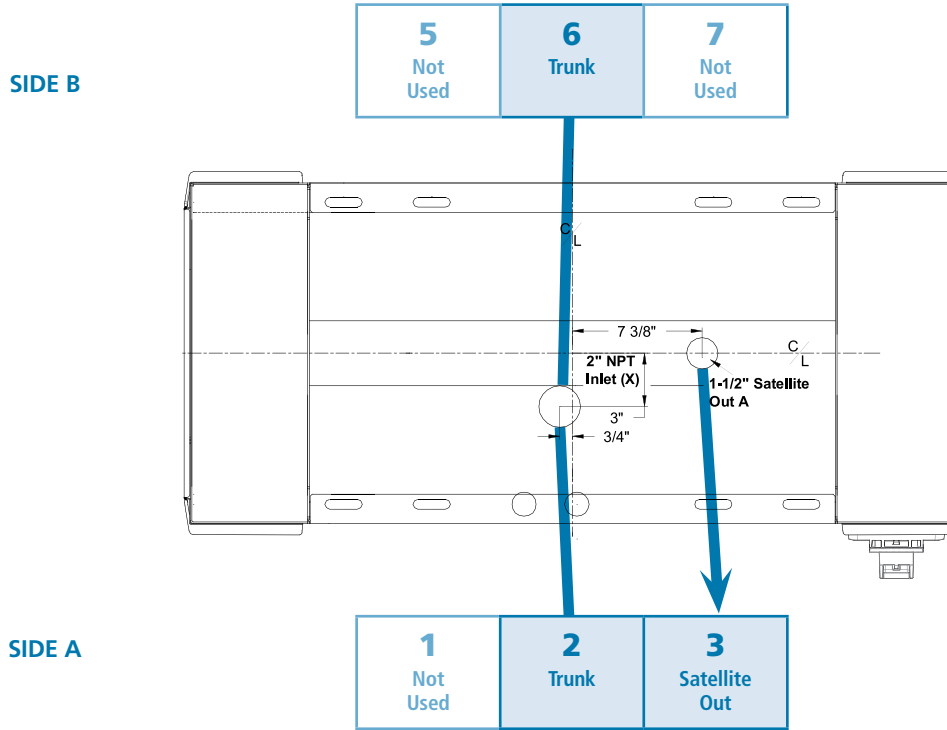

Wayne Ovation HS, Dual-Sided, Master

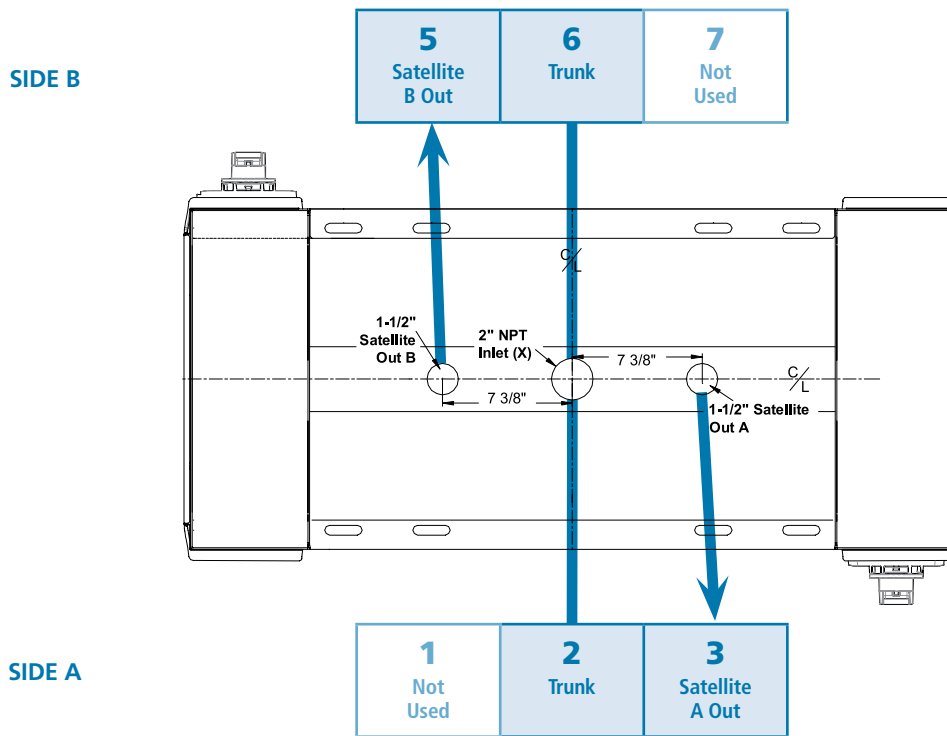

TOP VIEW OF BASES

The HiFlo Loop System™ Ordering Guide

Wayne Ovation HS, Master/Satellite

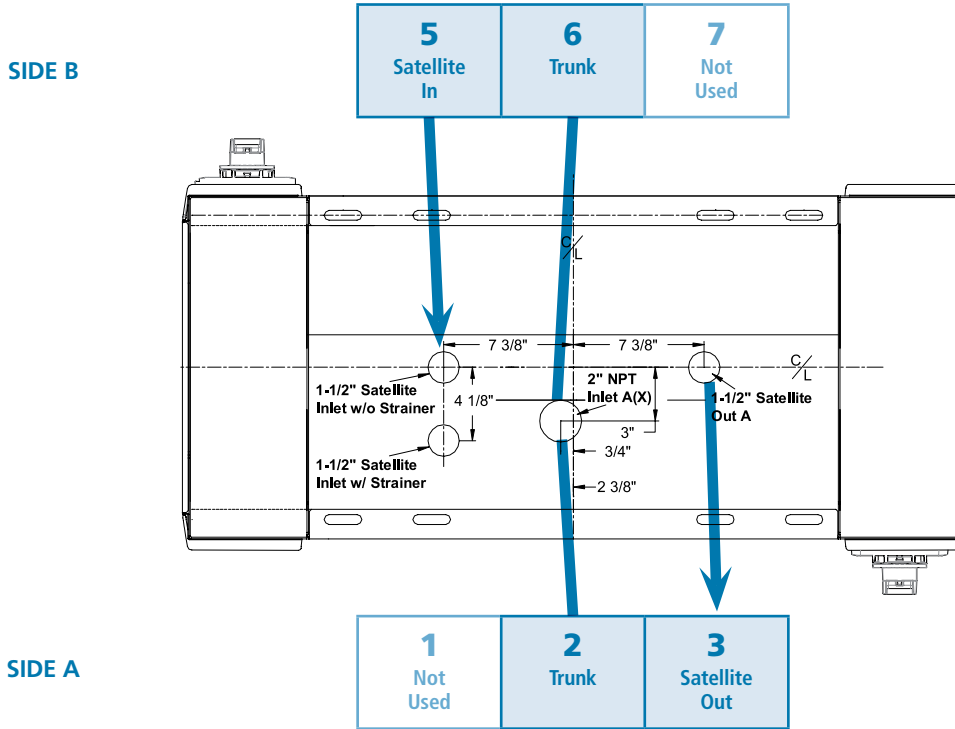

Wayne Ovation HS, Satellite

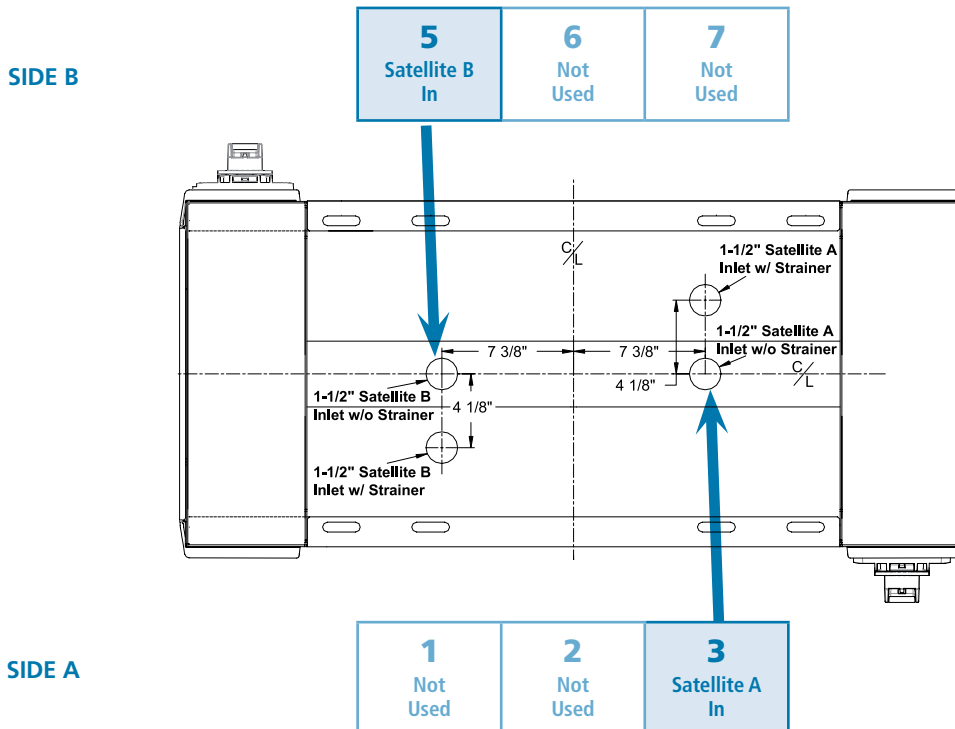

Note: For single-sided satellites, use position "3" on Side A.

TOP VIEW OF BASES

DEF Loop Configuration Ordering Guide*



Starting with 2010 models, DEF is now required in diesel-powered trucks utilizing Selective Catalytic Reduction (SCR) to meet federal emissions standards. The dispensing infrastructure at travel centers and fleet refueling sites continues to evolve as DEF-compatible equipment is installed. OPW's new 60V-DEF-SS Shear Valve body is made of 100% stainless-steel construction for unmatched compatibility. This double-poppet shear valve is third-party tested to ensure compatibility with the ISO 22241 Standard. With NPT connections on the top and NPT or NSPH threads on bottom of the loop-style valve, the 60V-DEF-SS shear valve provides peace of mind and minimizes damage to DEF-dispensing equipment in the case of impact collision, which will also help prevent product loss.

Benefits

- Compatible with Wayne Cold Weather Ovation w/DEF and Gilbarco Encore w/DEF
- Proprietary designed fully stainless-steel valve-body construction
- Utilizes a 1" NPT connection on the top and a 1.5" or 2" NPT/NPSH thread on the bottom for easy installation with a DEF-approved thread sealant, or DPC style couplings
- PEI RP1100 recommended materials used for double-poppet internals to contain product in the event of impact collision
- Machined shear groove for reliable shear performance
- Loop body version is designed to accommodate easy use with DEF recirculation systems



Shear Valve

Ordering Guide

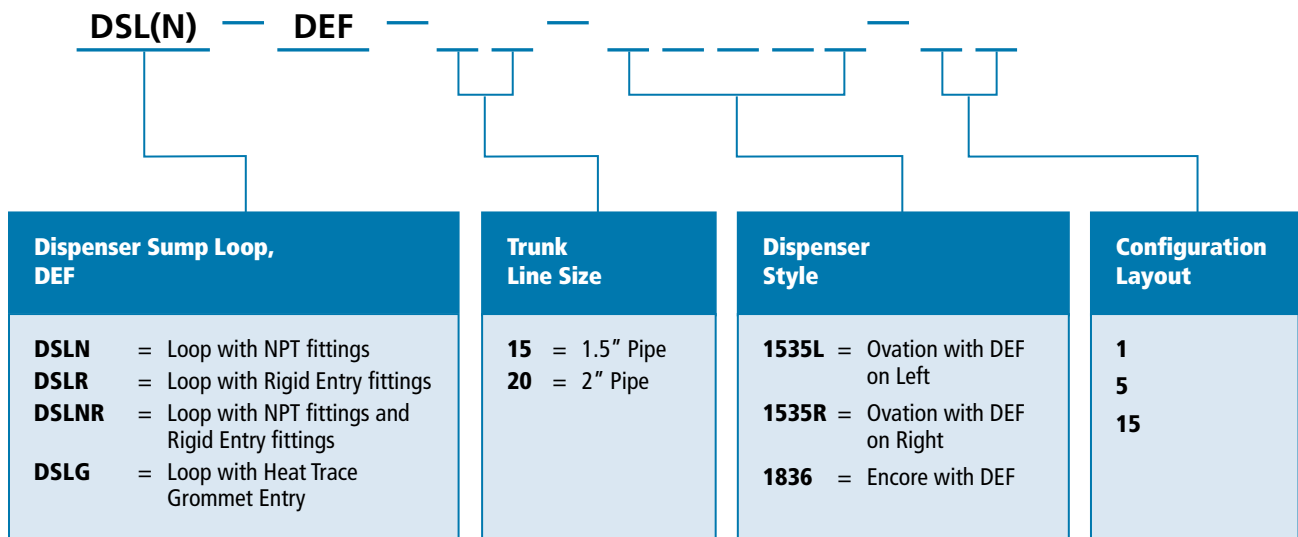

*A Side and B Side will change based on orientation.

DEF Loop Configuration Ordering Guide*



DEF for Ovation w/ Loop

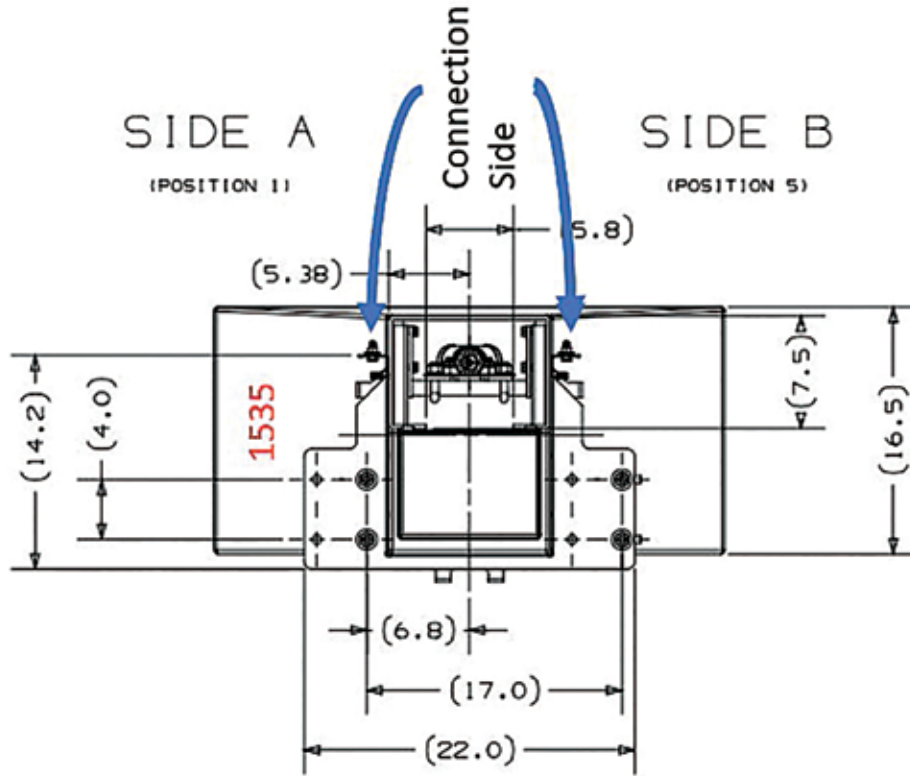

DEF for Encore w/ Loop

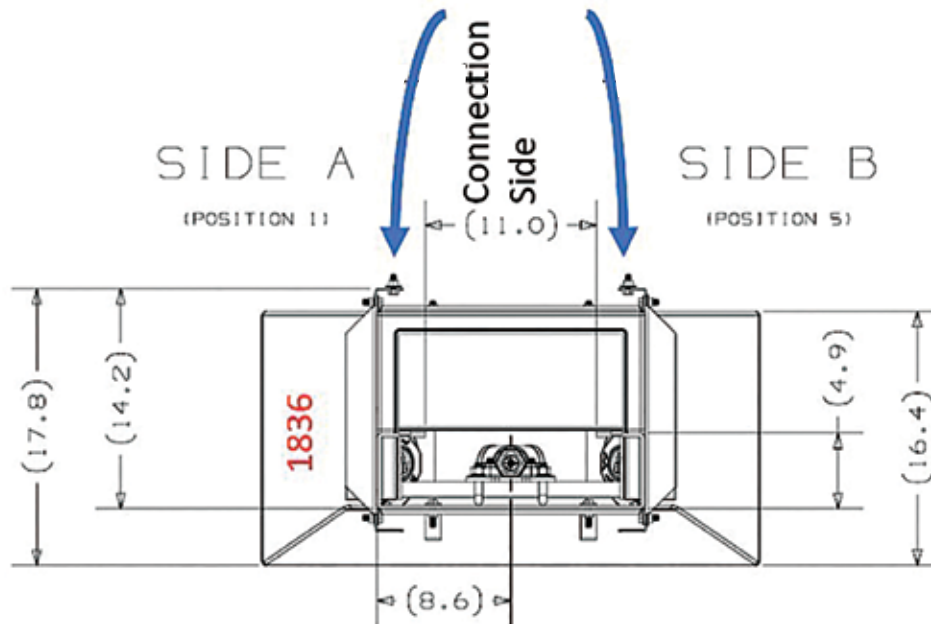

TOP VIEW OF BASES

The Loop System™ Ordering Guide

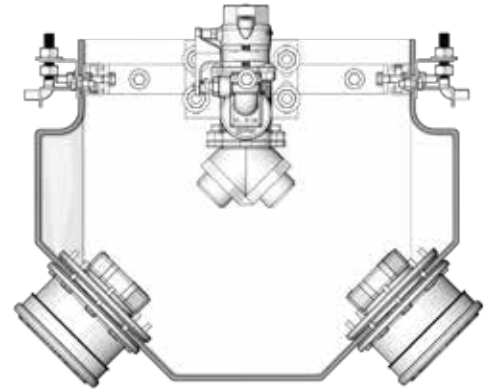

Loop Replacement Parts

Part #	Threads	Thread Size	Description
SVD-1522	NPSH	1.5"	Double poppet shear valve, Junction fitting and Mounting Plate
SVD-1522E85	NPSH	1.5"	E-85 Double poppet shear valve, Junction fitting and Mounting Plate
SVD-1522N	NPT	1.5"	Double poppet shear valve, Junction fitting and Mounting Plate
SVD-2022	NPSH	2.0"	Double poppet shear valve, Junction fitting and Mounting Plate
SVD-2022E85	NPSH	2.0"	Double poppet shear valve, Junction fitting and Mounting Plate
SVD-2022E85	NPSH	2.0"	Double poppet shear valve, Junction fitting and Mounting Plate
SVD-2022N	NPT	2.0"	Double poppet shear valve, Junction fitting and Mounting Plate
SVD-2522	NPSH	1.5" x 2"	Double poppet shear valve, Junction fitting and Mounting Plate
SVD-1524L	NPSH	1.5"	Double poppet shear valve, Elbow and Mounting Plate
SVD-1524E85L	NPSH	1.5"	E-85 Double poppet shear valve, Elbow and Mounting Plate
SVD-1524NL	NPT	1.5"	Double poppet shear valve, Elbow and Mounting Plate
SVD-2024L	NPSH	2.0"	Double poppet shear valve, Elbow and Mounting Plate
SVD-2024E85L	NPSH	2.0"	E-85 Double poppet shear valve, Elbow and Mounting Plate
SVD-2024NL	NPT	2.0"	Double poppet shear valve, Elbow and Mounting Plate
SVD-1524R	NPSH	1.5"	Double poppet shear valve, Elbow and Mounting Plate
SVD-1524E85R	NPT	1.5"	Double poppet shear valve, Elbow and Mounting Plate
SVD-1524NR	NPT	1.5"	Double poppet shear valve, Elbow and Mounting Plate
SVD-2024E85R	NPSH	2.0"	Double poppet shear valve, Elbow and Mounting Plate
SVD-2024NR	NPT	2.0"	E-85 Double poppet shear valve, Elbow and Mounting Plate
SVD-2024R	NPSH	2.0"	Double poppet shear valve, Elbow and Mounting Plate
10RPLUS-0152			1.5" 10 PLUS Replacement top, Double Poppet
10RPLUS-0202			2" 10 PLUS Replacement top, Double Poppet

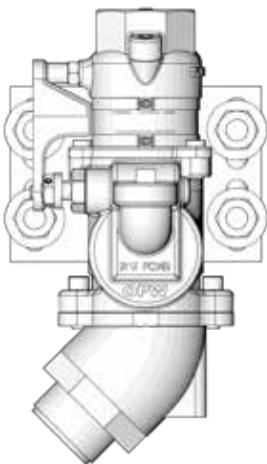

SVD - XX24L

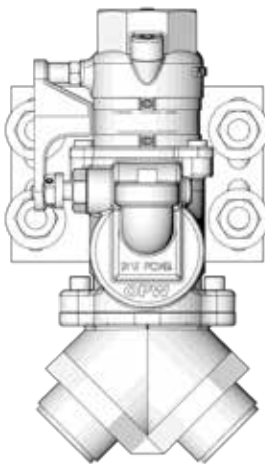

SVD - XX22

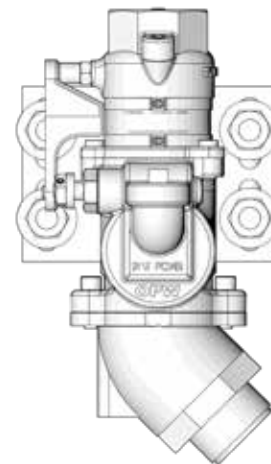

SVD - XX24R

Ordering Specifications - FlexWorks Dispenser Sump Selection Chart

Dispenser Manufacturer & Model	Dispenser Footprint Dimensions		FlexWorks One-Piece Polyethylene Sump	FlexWorks Wide-Access Polyethylene Sump	FlexWorks One-Piece Polyethylene Pan	FlexWorks One-Piece Fiberglass Sump	FlexWorks Wide- Access Fiberglass Sump	DSE Fiberglass Sump	Stabilizer Bar Kit
	in.	cm							
GILBARCO									
Commercial 625, 650, 684 Series (21" / 53" cm Frame)	15 ¹¹ / ₁₆ " x 21"	40 x 53	DS-1117F	---	DP-1117F	---	---	----	SBK-1100J
Salesmaker-2 Series (21" / 53 cm Frame)	15 ¹¹ / ₁₆ " x 21"	40 x 53	DS-1117F	---	DP-1117F	---	---	----	SBK-1100J
Highline 11B Series (21" Frame / 53 mm)	15 ¹¹ / ₁₆ " x 21"	40 x 53	DS-1117F	---	---	---	---	----	SBK-1100J
Highline 111B Series (27" / 69 cm Frame)	15 ¹¹ / ₁₆ " x 27"	40 x 69	DS-1123F	DSW-1123F	DP-1123F	---	---	----	SBK-1100J
Trimline 251, 252, 261, 262 (27" / 69 cm Frame)	15 ¹¹ / ₁₆ " x 27"	40 x 69	DS-1123F	DSW-1123F	DP-1123F	---	DSF-1123F	----	SBK-1100J
Trimline 154, 164, 251, 262 (27" / 69 cm Frame)	15 ¹¹ / ₁₆ " x 21"	40 x 53	DS-1117F	---	---	---	---	----	SBK-1100J
Commercial 650 Series (27" / 69 cm Frame)	15 ¹¹ / ₁₆ " x 27"	40 x 69	DS-1123F	DSW-1123F	DP-1123F	---	DSF-1123F	----	SBK-1100J
Highline Salesmaker Series	15 ¹¹ / ₁₆ " x 21"	40 x 53	DS-1117F	---	DP-1117F	---	---	----	SBK-1100J
Highline Salesmaker Series (27" / 69 cm Frame)	15 ¹¹ / ₁₆ " x 27"	40 x 69	DS-1123F	DSW-1123F	DP-1123F	---	DSF-1123F	----	SBK-1100J
Salesmaker-4 Series (27" / 69 cm Frame)	15 ¹¹ / ₁₆ " x 27"	40 x 69	DS-1123F	DSW-1123F	DP-1123F	---	DSF-1123F	----	SBK-1100J
Legacy Series	15 ¹¹ / ₁₆ " x 27"	40 x 69	DS-1123F	DSW-1123F	DP-1123F	---	DSF-1123F	----	SBK-1100J
Encore Series	LOOP SYSTEM- READY	23 ¹ / ₂ " x 40 ⁹ / ₁₆ "	60 x 103	DS-1836	DP-1836	FDS-4021	DSF-1836 DSF-1836C	DSE-1836	SBK-1800*
Advantage (36" / 91 cm Frame Models)	21 ¹ / ₂ " x 36"	55 x 91	DS-1630	DSW-1630	DP-1630	---	DSF-1630	----	SBK-1600
Advantage (48" / 122 cm Frame Models)	21 ¹ / ₂ " x 48"	55 x 122	DS-1642	---	---	---	---	----	SBK-1600*
MPD-1, MPD-2, MPD-3	16" x 48"	41 x 122	DS-1036	---	---	---	---	----	SBK-1000J
MPD Fixed Blender	16" x 48"	41 x 122	DS-1036	---	---	---	---	----	SBK-1000J
BENNETT									
Bennett Pacific	LOOP SYSTEM- READY	19 ¹ / ₂ " x 43 ¹ / ₂ "	49 x 110	DS-1543A	---	---	---	----	SBK-1500
Bennett 3000 Series		20" x 30"	51 x 76	DS-1123B	---	---	---	----	SBK-1100J
PD MCLAREN									
RDR HSx (Single Product, Single Hose)	21" x 17.75"	53 x 45	---	DSW-1922	---	---	---	----	SBK-1900
RDR HSx-D1 (Single Product, Dual Hose)	21" x 17.75"	53 x 45	---	DSW-1922	---	---	---	----	SBK-1900
RDR HSx-D2 (Dual Product, Dual Hose)	21" x 17.75"	53 x 45	---	DSW-1922	---	---	---	----	SBK-1900
RDR HSx-SAT (Master Unit and Satellites)	21" x 17.75"	53 x 45	---	DSW-1922	---	---	---	----	SBK-1900
RDR HSx-X2 (Single Product, Dual Hose, One at a Time)	21" x 17.75"	53 x 45	---	DSW-1922	---	---	---	----	SBK-1900

* For FDS-4021 Models, use Stabilizer Bar SBK-1800.

Ordering Specifications - FlexWorks Dispenser Sump Selection Chart

Dispenser Manufacturer & Model	Dispenser Footprint Dimensions		FlexWorks One-Piece Polyethylene Sump	FlexWorks Wide-Access Polyethylene Sump	FlexWorks One-Piece Polyethylene Pan	FlexWorks One-Piece Fiberglass Sump	FlexWorks Wide- Access Fiberglass Sump	DSE Fiberglass Sump	Stabilizer Bar Kit
	in.	cm							
GASBOY									
0215A, 216A (19 ⁷ / ₈ " Frame / 50.5 mm)	17 ¹ / ₄ " x 19 ⁷ / ₈ "	44 x 50.5	DS-1117F	---	DP-1117F	---	---	---	SBK-1100J
52 and 53 Series	17" x 19 ⁷ / ₈ "	43 x 50.5	DS-1117F	---	DP-1117F	---	---	---	SBK-1100J
8700, 8800, 9100, 9800 Series	17 ¹ / ₄ " x 25"	43 x 63.5	DS-1120	---	---	---	---	---	SBK-1100J
8700, 8800, 9100, 9800 Series (28 ³ / ₄ " Frame / 72 mm)	17 ¹ / ₄ " x 28"	44 x 71	DS-1123	DSW-1123	DP-1123	---	DSF-1123F	---	SBK-1100J
9850A	15 ¹¹ / ₁₆ " x 21"	40 x 53	DS-1120	DSW-1120	---	---	DSF-1120	---	SBK-1100J
Atlas X	19 ⁵ / ₈ " x 32 ¹ / ₄ "	50 x 82	DS-1928	---	---	---	---	---	---
* Stabilizer bar is installed widthwise in dispenser sump									
DRESSER / WAYNE									
350, 357, 358, 360, 370 Series	15" x 25 ⁷ / ₈ "	38 x 66	DS-1123F	DSW-1123F	DP-1123F	---	DSF-1123F	---	SBK-1100J
Vista 380 Series (387, 389)	20" x 35"	51 x 89	DS-1229	---	---	---	---	---	SBK-1200J
Vista 590 Series (590, 595)	20" x 48"	51 x 122	DS-1242	---	---	---	---	---	SBK-1200J
Vista 390 Series (395, 399)	20" x 48"	51 x 122	DS-1242	---	---	---	---	---	SBK-1200J
Vista 490 Series	20" x 48"	51 x 122	DS-1242	---	---	---	---	---	SBK-1200J
DL390, 395, 399 Series	20" x 48"	51 x 122	DS-1242	---	---	---	---	---	SBK-1200J
HS1 Satellite / 287 S 	20" x 35"	51 x 89	DS-1229	---	---	---	---	---	SBK-1200J
Ovation ₂	19 ¹ / ₂ " x 43 ¹ / ₂ "	50 x 110	DS-1543A	---	DP-1543	FDS-4319*	DSE-1543	DSE-1543	SBK-1500
Select	19 ³ / ₈ " x 32 ⁵ / ₁₆ "	49 x 82	DS-1928	---	---	---	---	---	SBK-1500
Global Century	19 ³ / ₈ " x 32 ⁵ / ₁₆ "	49 x 82	DS-1928	---	---	---	DSF-1630	---	SBK-1500
Reliance	19 ³ / ₈ " x 32 ⁵ / ₁₆ "	49 x 82	DS-1928	---	---	---	DSF-1630	---	SBK-1500
HS4 / HS3 / Vista	19 ³ / ₈ " x 32 ⁵ / ₁₆ "	49 x 82	DS-1630	DSW-1630	DP-1630	---	DSF-1630	---	SBK-1600
Narrow Frame Helix  (2000, 4000)	20" x 33"	51 x 84	DS-1630	---	---	---	DSF-1630	---	SBK-1600
Wide Frame Helix (5000)	26" x 44"	66 x 112	DS-1741	---	---	---	---	DSE-1741	SBK-1700
TOKHEIM									
1200, 1248, 1250 Series	17 ¹ / ₄ " x 25"	44 x 64	DS-1120	DSW-1120	---	---	DSF-1120	---	SBK-1100J
330B, 333B Series	17 ¹ / ₄ " x 44"	44 x 112	DS-1642	---	---	---	---	---	SBK-1600

* For FDS-4319 Model use Stabilizer Bar SBO-0250

DSE Dispensing Sump

OPW brings you a new dispenser sump that delivers cost-effective peace of mind for retail-fueling operators. The innovative DSE combines superior design, premium materials and world-class manufacturing expertise without breaking the bank, and its fast, reliable construction means it's ready to slot into your station right away.

Stacked with Features

DSE Dispenser Sumps fit into your existing dispensing network with ease. The sump base is designed to create strong bonds with fiberglass and flexible pipe and fittings. The DSE's universal base is sized to nest perfectly inside itself, while the feet and specialized grooves help it to unstack with ease.



Sump: Fiberglass

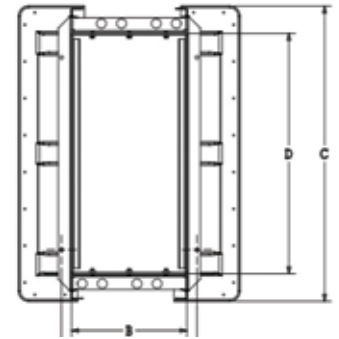

Ordering Specifications - DSE Dispenser Sumps

Dimensions

Sump Model Number	A		B		C		D	
	in.	cm	in.	cm	in.	cm	in.	cm
DSE-1836	20.22	51.36	17.20	43.69	44.11	112.04	35.90	91.19
DSE-1543	17.18	43.64	14.60	37.08	45.90	116.59	38.90	98.81
DSE-1741	18.50	46.99	16.70	42.42	44.20	112.27	38.10	96.77

Separate Component Part Numbers

Part Number	Description
DSE-BASE	Description: DSE Universal Base. Combines with any DSE top
DSE-TOP-1836	Gilbarco Encore Top. Combine with DSE-BASE to make DSE-1836
DSE-TOP-1543	Wayne Ovation Top. Combine with DSE-BASE to make DSE-1543
DSE-TOP-1741	Wayne Helix Top. Combine with DSE-BASE to make DSE-1741

ONE BASE



THREE DIFFERENT TOPS

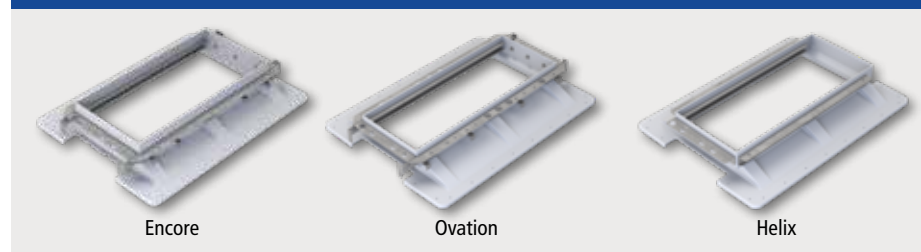

FEATURE	COMPETITOR	OPW	VALUE
Advanced Composite Manufacturing Technology	👎	👍	Provides dependable quality each and every time with consistent wall thickness, material blend, sump shape and detail
Quick and Efficient Manufacturing Time per Unit	👎	👍	Shortest lead time of any fiberglass sump in the industry; best value for the price on the market
Designed for Easy Nesting, Stacking and Unstacking	👎	👍	Maximizes distributor warehouse, construction trailer and jobsite space; lowers shipping costs
Smooth Surface on Both Sides of the Sump Wall	👎	👍	Enhanced leak-resistant sealing surface for all types of entry fittings
One Base for All Dispenser Models	👎	👍	Reduces distributor inventory and improves ease of ordering; all sump models are conduitless with wide access
Closed-Molded Manufacturing Process	👎	👍	Eliminates worker and environmental exposure to resin vapors or glass fibers

Pre-Plumbed DSE Dispenser Sump

Utilizing the quality and value of the DSE Dispenser Sump, OPW now offers a Pre-Plumbed DSE for customers who wish to save time and costs of installation.

Complete with factory-assembled and tested components, the Pre-Plumbed DSE continues the OPW E-Series tradition of superior design, materials, and affordability. The OPW Loop System® without the “loop”.

All elbows, tees and rigid NPT pipe nipples e-coated for superior protection and performance.

The Pre-Plumbed DSE ships installed with the following items:

- ◆ Tops (Wayne Ovation or Gilbarco Encore)
- ◆ Pipe Entry Fittings
- ◆ Stabilizer Bars
- ◆ OPW 10 Plus Double-Poppet Emergency Shear Valves
- ◆ Flex Connectors or Rigid Risers (NPT Pipe Nipples)
- ◆ Elbows/Tees (DPC or SBC compatible)

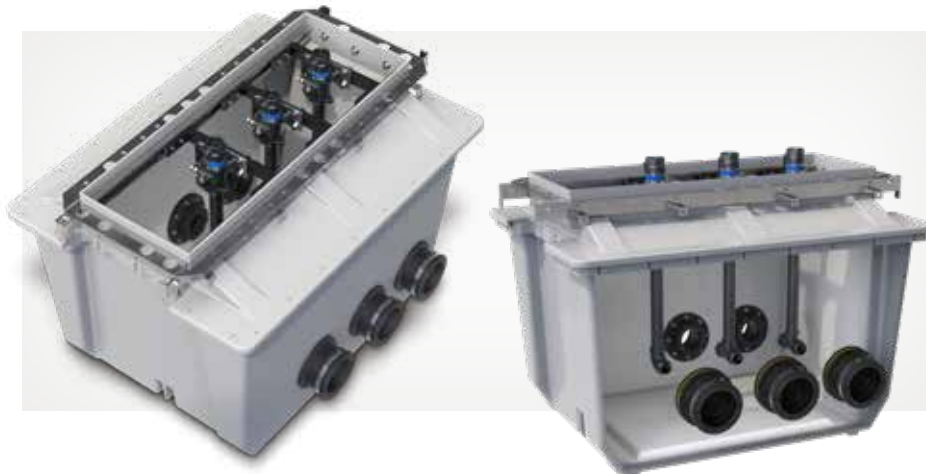

Features & Benefits:

- ◆ **Quality Components Factory-Installed** – pre-plumbed dispenser sump provides convenience and installation cost/time savings
- ◆ **Piece-of-Mind Installation** – components are factory installed and tested in a controlled environment eliminating potential costly installation errors in the field
- ◆ **Advanced Composite Technology** – premium construction of a robust fiberglass product with smooth surfaces on both sides of the sump walls and consistent thickness, blend and shape for strong bonds with entry fittings
- ◆ **Customizable** – choose your configuration by dispenser type, entry fittings, traditional or renewable shear valves, flex connector or rigid riser, and pipe coupling type
- ◆ **Efficient Manufacturing and Fast Lead Times** – provides best-in-class quality and value shipped quickly
- ◆ **Loop System Advantages** – all the features and benefits of the legendary OPW Loop System for jurisdictions that still require piping slope back to the tank

Components

Part Configurations

Base	DSE-BASE			
Tops	DSE-1836	Gilbarco Encore	DSE-1543	Wayne Ovation
Stabilizer Bars	SBK-1800	Gilbarco Encore	SBK-1500	Wayne Ovation
Pipe Entry Fittings	REF-4015	1.5" Rigid Entry Fittings	HEF-4015	1.5" Hybrid Entry Fittings
	REF-4020	2.0" Rigid Entry Fittings	HEF-4020	2.0" Hybrid Entry Fittings
Emergency Shear Valves	10P-0152	10 Plus 1.5" Double Poppet	10P-0152RF*	Renewable Fuel 10 Plus 1.5" Double Poppet
Flex Connectors or Rigid Risers (1.5" x 18")	217817	1.5" NPT Pipe Nipple, 18" length (Rigid Riser)	FC15-SWM18	1.5" Flex Connector Male Swivel x Male, 18" length
Pipe-Coupling Compatibility**	Double Wall Swivel Pipe Couplings (DPC)		Swivel Bolt-On Couplings (SBC)	

*E85/B100 Applications. All shear valves in the Pre-Plumbed DSE will be RF version if selected.

** DPC & SBCs must be purchased separately. The proper e-coated tees & elbows to be pre-installed based on selection.



Pre-Plumbed DSE Dispenser Sump Ordering Guide

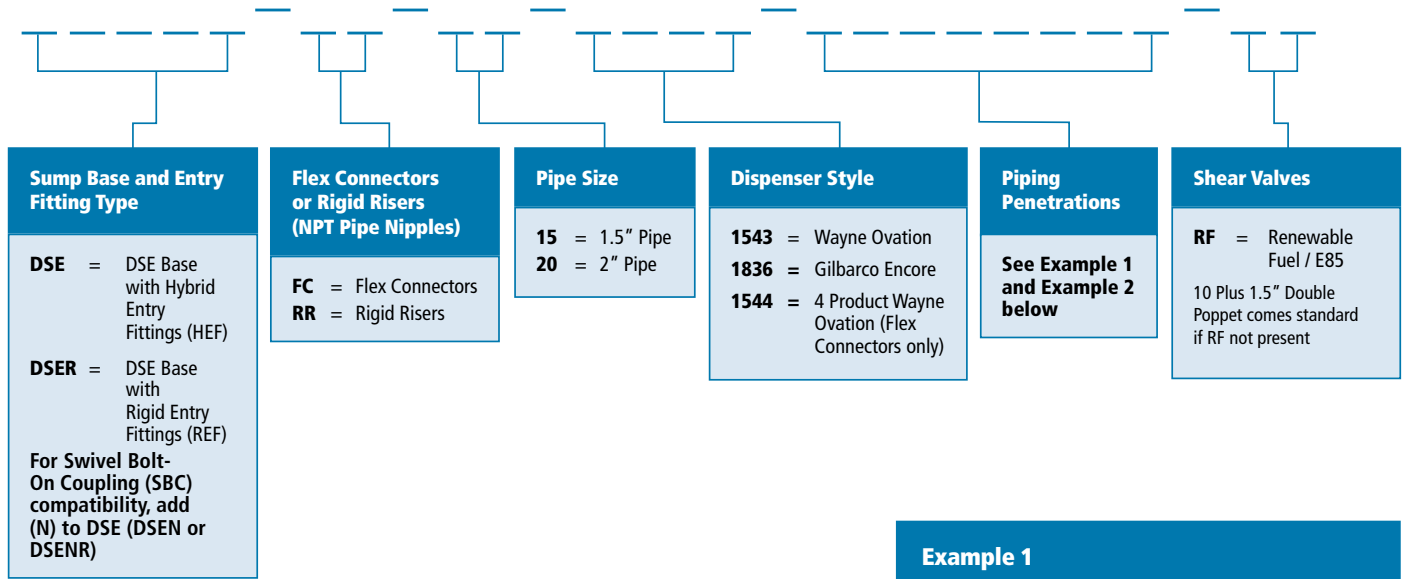

Example 1

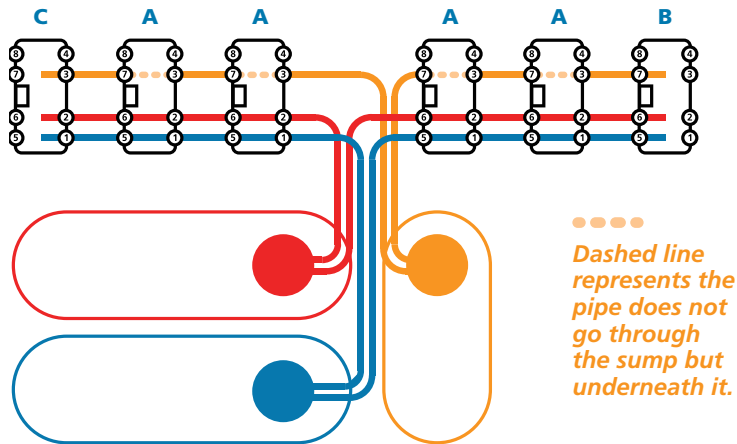

Example 1

- DSE-FC-15-1836-1256
 - DSE-FC-15-1836-567
 - DSE-FC-15-1836-123
- Hybrid Entry Fittings (DSE in part number)
 - DPC compatible (No N present in part number)
 - Flex Connectors (FC in part number)
 - 1.5" pipe (15 in part number)
 - Gilbarco Encore dispensers (1836 in part number)
 - The two 3+1 dispensers have different configurations, B & C

Example 2

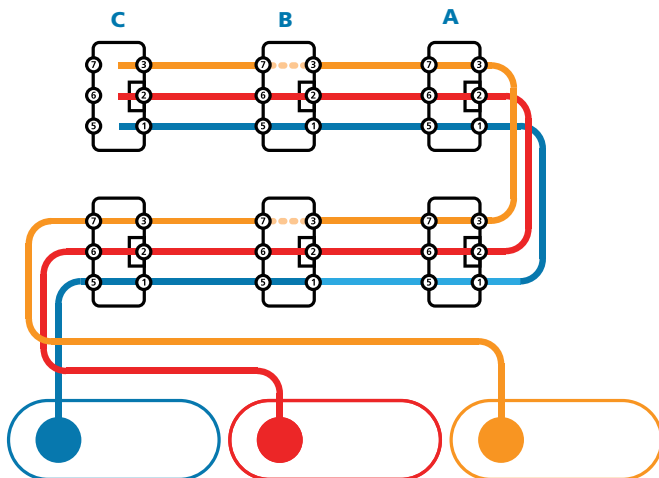

Example 2

- DSE_RN-RR-15-1543-123567
 - DSE_RN-RR-15-1543-1256
 - DSE_RN-RR-15-1543-123
- Rigid Entry Fittings
 - SBC compatible NPT tees/elbows (N present in part number)
 - Rigid Risers (RR in part number)
 - 1.5" pipe (15 in part number)
 - Wayne Ovation dispensers (1543 in part number)
 - The product lines cross in order to keep the dispenser "Side A" consistent

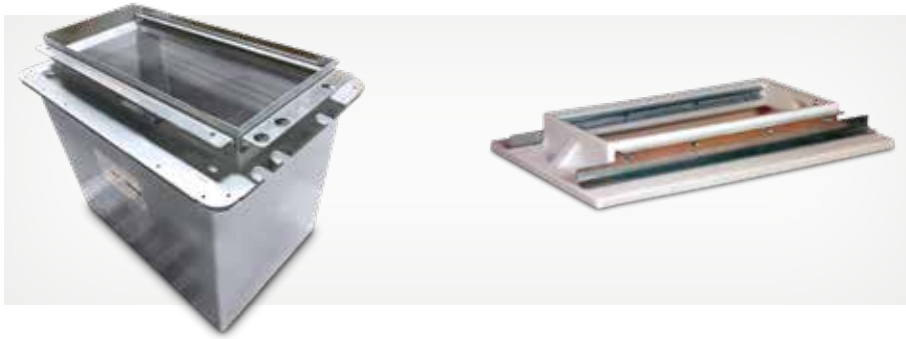

Wide-Access Fiberglass Dispenser Sumps

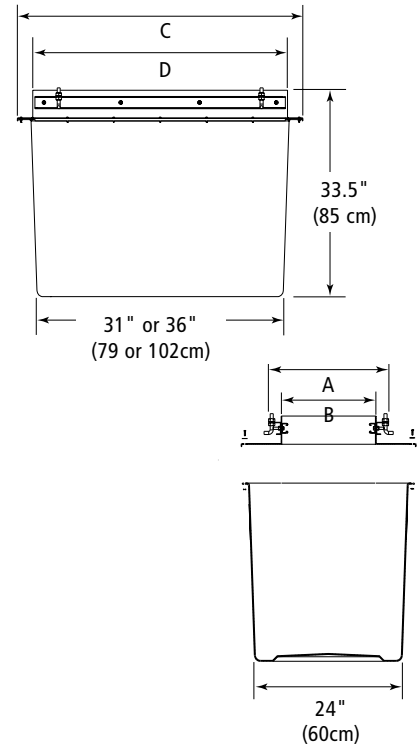

Features & Benefits:

- ◆ **Conduitless Design** – the fiberglass base and metal cap and frame are designed to directly conduit into the dispenser along the side of the sump to avoid requiring additional entry boot penetrations
- ◆ **Multi-Product Flexible** – the wide sump surface area is designed to accommodate up to 4 product lines into the sump
- ◆ **Structural Integrity** – engineered with thick side walls to withstand backfill and high water table forces. Precise glass and resin metering throughout the molding process ensures material consistency and maximizes the strength-to-weight ratio
- ◆ **Full-Perimeter Liquid Collection Channel** – facilitates quick leak detection and allows flexibility in locating leak sensors
- ◆ **Smooth Sealing Surfaces For Leak-Tight Sump Entry Fittings** – our fully enclosed molding manufacturing method produces a uniform wall thickness while eliminating air entrapment. The result is a flat, smooth finish, both inside and out, which provides leak-tight pipe entries
- ◆ **Convenient Shipping and Storage** – sump boxes are nestable. Two sizes accept multiple frames to accommodate all common dispensers
- ◆ **Full-Access Working Area** – frame is attached after plumbing is complete
- ◆ **Mounting Flange** – sump rests on island form crossbars for support during installation

Ordering Specifications - Wide Access Fiberglass Dispenser Sumps

Sump Model #	Dimensions								Weight with Top		Box Part #	Top Assembly Part #
	A		B		C		D		lbs.	kg		
	in.	cm	in.	cm	in.	cm	in.	cm				
DSF-1123	15	38	11	28	37	94	23	58	94	43	E00590M	D02212
DSF-1123F *	15	38	11	28	37	94	23	58	94	43	E00590M	D02213

SL-1100 Urethane Sealant - One Tube required per Sump (Packaged 12 tubes/case)

* Flush Mount model supplied without rain lip due to dispenser frame clearance limitations; Frame Gasket Included. Anchor bolts provided, Stabilizer Bar Kits ordered separately; One kit required for each emergency and vapor valve. Refer to FlexWorks Dispenser Sump Selection Chart (See Pages 38 - 39 of this catalog) to select sumps for particular dispensers. **Yellow indicates metal top model.**

** These sumps are designed for Conduitless applications.

*** C Conduitless



Wide-Access Polyethylene Dispenser Sumps

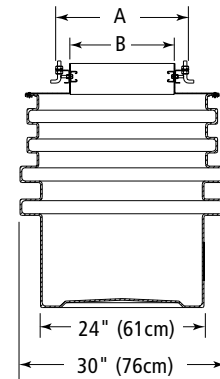
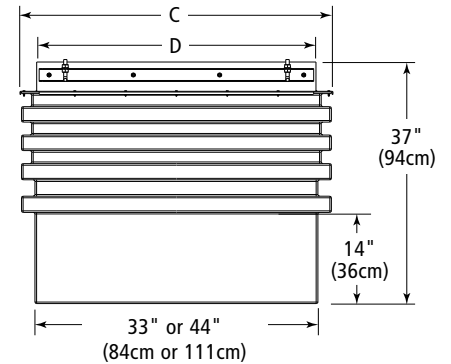

Features & Benefits:

- ◆ **Contractor-Friendly Installation** – open top provides unrestricted access to the inside of the containment chamber to facilitate entry fitting and piping installation. Dispenser mounting frame is attached after plumbing is complete
- ◆ **Deeper Burial Capability** – 37" burial depth allows piping slope requirements to be met more easily in layouts with long piping runs
- ◆ **Simple Field-Height Adjustment** – the top portion of the chamber can be quickly and easily trimmed along the ribs to ensure maximum installation flexibility
- ◆ **Full Perimeter Liquid-Collection Channel** – facilitates quick leak detection and allows flexibility in locating leak sensors
- ◆ **Convenient Shipping and Storage** – sump boxes are partially nestable. Two chamber sizes accept multiple frames to accommodate all common dispensers
- ◆ **Polyethylene Top** – polyethylene top will not corrode

Ordering Specifications - Wide Access Polyethylene Dispenser Sumps

Sump Model #	Dimensions								Weight with Top		Box Part #	Top Assembly Part #
	A		B		C		D		lbs.	kg		
	in.	cm	in.	cm	in.	cm	in.	cm				
DSW-1123	15	38	11	28	37	94	23	58	94	43	E00590M	D02212
DSW-1123F *	15	38	11	28	37	94	23	58	94	43	E00590M	D02213
DSW-1630	20	51	16	41	37	94	30	76	87	40	E00590M	D02536

SL-1100 Urethane Sealant - One Tube required per Sump (Packaged 12 tubes/case)

* Flush Mount model supplied without rain lip due to dispenser frame clearance limitations; Frame Gasket Included. Anchor bolts provided, Stabilizer Bar Kits ordered separately; One kit required for each emergency and vapor valve. Refer to FlexWorks Dispenser Sump Selection Chart (See Pages 38 - 39 of this catalog) to select sumps for particular dispensers. **Yellow indicates metal top model.**

** Conduitless with Offset Top.

*** Conduitless Narrow Base.

One-Piece Polyethylene Dispenser Sumps

FlexWorks Dispenser Sumps are installed beneath fuel dispensers to provide access to and secondary containment of dispenser plumbing, emergency shear valves and underground piping connections. Stabilizer Bar Kits are installed in FlexWorks Dispenser Sumps to provide reliable support for boss-mounted emergency shear valves.



Features & Benefits:

- ◆ **Multiple Models** – ensure a custom fit.
- ◆ **Structural Reinforcing on Large MPD Models** – prevents sump deformation from backfill and high water table forces.
- ◆ **Light Color** – preserves rigidity in sunlight before backfill and provides maximum visibility after installation.
- ◆ **Full Perimeter Liquid-Collection Channel** – facilitates quick leak detection and allows flexibility in locating leak sensors.
- ◆ **Integral Rain Lip** – protrudes into the dispenser frame to prevent surface water entry.
- ◆ **Easy Installation** – field-height adjustment capability and large pipe entry area ensures installation flexibility.
- ◆ **Many Are Available in a Conduitless Model** – eliminates conduit entry fittings and prevents a notorious leak point inside dispenser sumps.

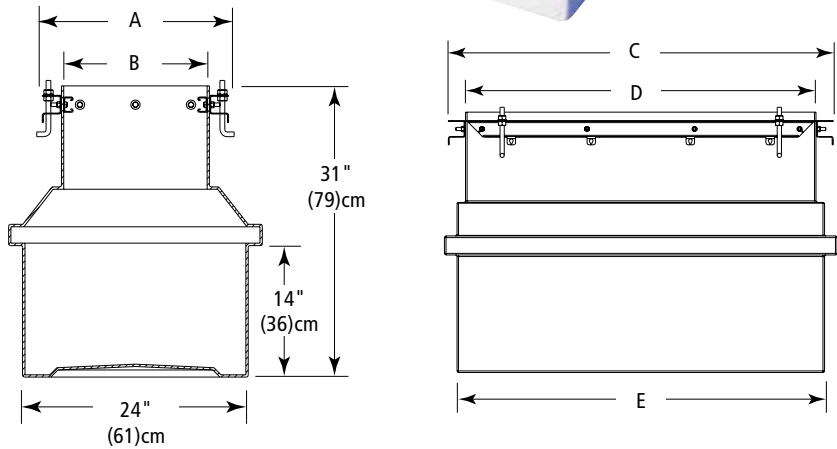

Ordering Specifications* - One-Piece Polyethylene Dispenser Sumps

Model #	Conduitless Frame	A		B		C		D		E		Weight	
		in.	cm	in.	cm	in.	cm	in.	cm	in.	cm	lbs.	kg.
DS-1036	No	14	36	10	25	40	102	36	91	38	97	65	30
DS-1117F**	Yes	14.5	37	10.5	27	20.5	52	16.5	42	18.5	47	32	15
DS-1120	Yes	15	38	11	28	24	61	20	51	25	64	33	15
DS-1123	Yes	15	38	11	28	27	69	23	58	25	64	33	15
DS-1123B	Yes	18.5	47	11	28	27	69	23	58	25	64	33	15
DS-1123F**	Yes	15	38	11	28	27	69	23	58	25	64	33	15
DS-1229	No	15.5	39	11.5	29	33	84	29	74	31	79	49	22
DS-1242	Yes	15.5	38	11.5	29	46	117	42	107	44	112	84	38
DS-1543A	Yes	19	48	15	38	43	109	39	99	41	104	84	38
DS-1630	No	20	51	16	41	34	86	30	76	32	81	52	23
DS-1630B	No	20	51	16	41	34	86	30	76	32	81	52	23
DS-1642	Yes	20	51	16	41	46	117	42	107	44	112	84	38
DS-1836	Yes	21.5	55	17.5	44	40.5	103	36.5	93	39	99	70	32
DS-1928	Yes	18	46	14.8	38	30	76	26	66	28.5	72	50	23
DS-1741	No	21	53	17	43	44.7	114	40.6	103	42.6	108	80	36

* Refer to FlexWorks Dispenser Sump Selection Chart to select sumps for particular dispensers (See pages 38 - 39 of this catalog)

** Flush mount model supplied without rain lip due to dispenser frame clearance limitations; Frame gasket included. Anchor bolts provided, Stabilizer Bar Kits ordered separately; One kit required for each emergency and vapor shear valve.

FlexWorks Polyethylene Dispenser Pans

FlexWorks Dispenser Pans are installed beneath fuel dispensers to provide secondary containment of dispenser plumbing and emergency shear valves. Dispenser pans are commonly used with rigid fuel pipe and to retrofit existing dispensers.

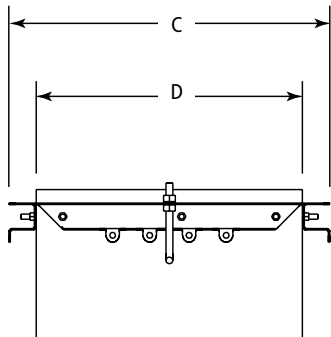
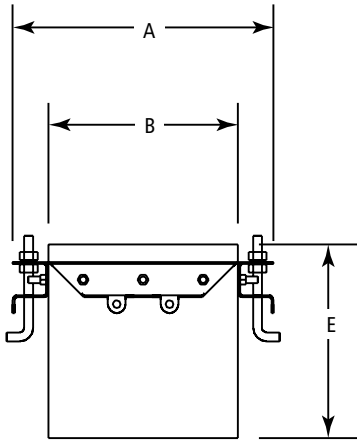

Ordering Specifications FlexWorks Polyethylene Dispenser Pan

Model *	Conduitless Frame	Dimensions										Weight	
		A		B		C		D		E		lbs.	kg
		in.	cm	in.	cm	in.	cm	in.	cm	in.	cm		
DP-1117F	Yes	14½	37	10½	27	20½	52	16½	42	11	28	20	9
DP-1123	Yes	15	38	11	28	27	69	23	58	11	28	23	10
DP-1123F	Yes	15	38	11	28	27	69	23	58	11	28	23	10
DP-1543	Yes	19	48	15	38	43	109	38.8	99	11	28	44	20
DP-1630	No	20	51	16	41	34	86	30	76	11	28	38	17
DP-1836	Yes	21½	55	17½	44	40	102	36	91	11	28	50	23

*Flush Mount Model (F) Supplied without Rain Lip Due to Dispenser Frame Clearance Limitations; Supplied with Frame Gasket. Anchor Bolts Provided, Stabilizer Bar Kits Ordered Separately; One Kit Required for each Emergency Shut-Off Valve.

DEF Containment Sumps

Offering both the DEF Loop Sump - a fast, DEF-specific bolt-on sump with the same great value of Loop - and the same bolt-on containment sumps to be installed for a traditional UDC.

- ◆ DEF containment adapted to the same profile as our one-piece polyethylene Dispenser Sumps for Encore and Ovation II.
- ◆ Depending on dispenser configuration, sumps can be bolted on either side to fit within the dispenser manufacturer's footprint.
- ◆ For an Encore dispenser, the DS-DEF-1836 is a traditional style DEF UDC, which can be added to either a DSE-1836, or DS-1836. This sump requires an SBK-1800 stabilizer bar.
- ◆ For an Ovation II dispenser, the DS-DEF-1535 is a traditional style DEF UDC, which can be added to the DS-1535. This sump requires an SBK-1100C.



DS-DEF-1535

Standard Configuration

Containment Sump		DEF Sump
DSE-1836 DS-1836	+	DS-DEF-1836
DS-1535	+	DS-DEF-1535

Loop Configuration

DSLH/DSLHF-XX-1836-XXX	+	DSLXX-DEF-XX-1836
DSLH/DSLHF-XX-1535-XXX	+	DSLXX-DEF-XX-1535L/R

Available Heat Trace Entry Fittings – HEF-4015G and HEF-4020G – for 1.5" or 2" FlexWorks designed specifically for DEF.

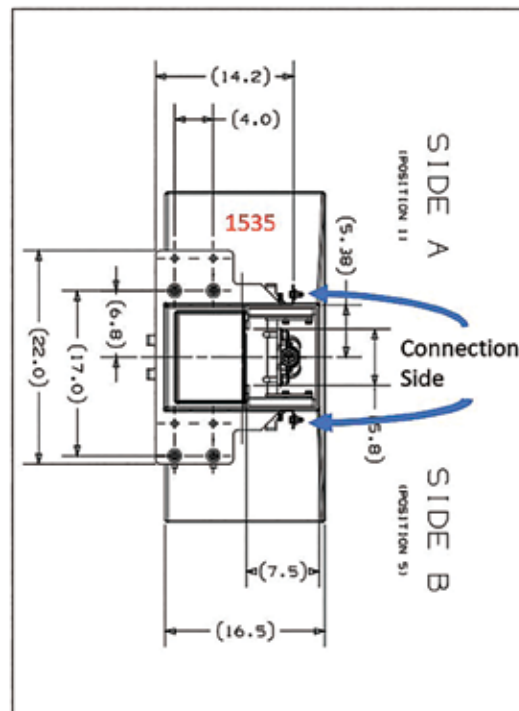
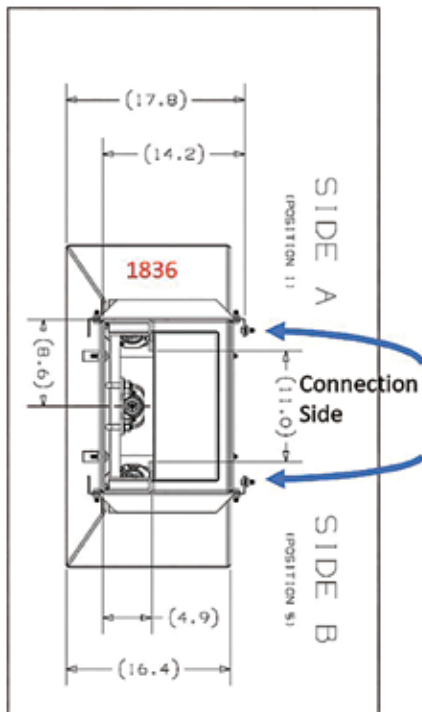



Flex Connector Isolation Components

The FIT-3530 is used to isolate and contain Flex Connectors.

Ordering Specifications - Dispenser Pan Fittings & Accessories

Model	Application	Weight	
		lbs.	kg
FIT-3530	Flexible Isolation Jacket, 30" (76 cm) Long x 3.5" (9 cm) I.D.	2	1
ITR-3015	Isolation Tube Reducer, 3" x 1.5"	1	.5
ITR-3020	Isolation Tube Reducer, 3" x 2"	1	.5

Dispenser Sump Accessories

FlexWorks pipe Stabilizer Bar Kits provide reliable support inside dispenser sumps/ pans for boss-mounted emergency shear valves. One kit is required for each emergency valve and vapor shear valve.

Ordering Specifications - Stabilizer Bar Kit

Model #	0 (for Sump/Pan) DS-, DSW, DSF, FDS	Weight	
		lbs.	kg
SBK-1000J	1036	5	2.3
BK-1100C	DS-DEF-1535	6	2.8
SBK-1100J	1117F, 1123, 1123F, 1120	5	2.3
SBK-1200J	1229, 1242	6	2.8
SBK-1500	Ovation Product Line (DS-1543A, DSW-1543, DS-1928)	7	3
SBK-1500V	Ovation Vapor Line (DSW-1543, DS1543A)	7	3
SBK-1600	1630, 1642	7	3
SBK-1700	DSF-1741C	7	3
SBK-1800	1836, FDS-4021	7	3
SBO-0250	Ovation FDS-4319	6	2.8
SBO-0300	FDS-4319-DW	6	2.8
SBO-0700	FDS-4021-DW	6	2.8
MPK-10*	Extra Mounting Plate Kit	2	1
C04400M	Stabilizer Bar Mounting Plate Only under the MPK-10*		

* Stabilizer bar is installed width-wise in dispenser sump. One valve mounting plate is included. Additional MPK-10 mounting plate kit is required for additional valves.

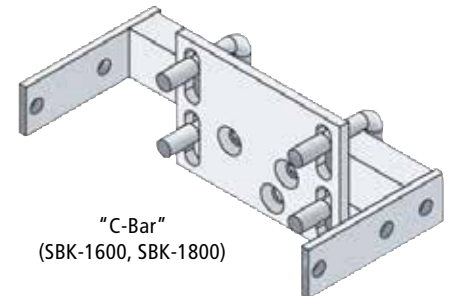

"C-Bar"
(SBK-1600, SBK-1800)

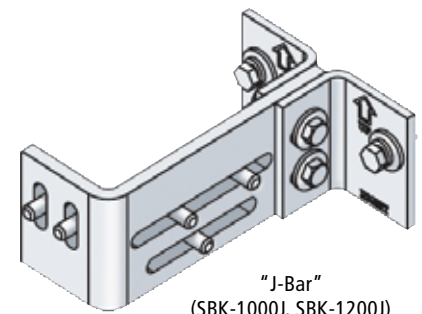

"J-Bar"
(SBK-1000J, SBK-1200J)

Automatic Fire-Extinguisher System

The FlexWorks Automatic Fire-Extinguisher System is a small, non-rechargeable fire extinguisher designed specifically to be installed in a containment sump underneath an aboveground fuel dispenser, and to automatically extinguish a fuel fire in the event of a dispenser knock-over. The FlexWorks Fire-Extinguisher System will automatically activate and discharge its extinguishing agent when the surrounding temperature reaches 175°F (79°C). The fire extinguisher comes with its own mounting bracket and can be mounted to a variety of surfaces. The fire extinguisher contains enough extinguishing agent to protect dispenser containment sumps up to a maximum capacity of 50 cubic feet.

Features

- ◆ Charged with a clean agent – FK-5-1-12
- ◆ Operating temperatures of 32° to 130° F (0° to 54° C)
- ◆ One-year replacement warranty
- ◆ Low-cost solution to a potentially expensive problem

Benefits

- ◆ Extinguishes fuel fires quickly
- ◆ Provides year-round fire protection
- ◆ No certified annual testing required
- ◆ May reduce fire insurance premiums



Fire Prevention

Dispenser and UST containment sumps offer significant environmental protection by providing secondary containment and corrosion protection of valves and pipe fittings. Under certain conditions, a potential fire hazard could develop. Should a fire occur inside the containment chamber, the FlexWorks Automatic Fire-Extinguisher System automatically extinguishes the fire in a matter of seconds, protecting patrons, underground piping, shear valves and sump.

Application	Dispenser Containment Sump
Agent	FK-5-1-12
Coverage Area:	50 ft. ³ (1.42m ³)
Atmospheric Life	Less than one day
Activation Temp:	175°F (79°C)
Operating Temp Range:	32° to 130° F (0° to 54° C)

Ordering Specifications - FlexWorks Automatic Fire-Extinguisher System

Model	Description
FSS-50	FlexWorks Automatic Fire-Extinguisher System



The "REF" Rigid Entry Fitting

As a result of OPW's all-inclusive development program to bring Next Generation Solutions to the market, OPW is proud to announce the release of our new state-of-the-art Rigid Entry Fitting.

How is this fitting different than other fittings in the industry? Our new Rigid Entry Fitting has minimal exposed rubber, yet still accommodates ground movement. The sealing redundancy throughout the fitting provides maximum containment and unmatched protection from water intrusion.

Ordering Specifications - REF Rigid Entry Fitting

Model #	Description	Weight	
		lbs.	kg
REF-0075C	Rigid Entry Fitting, 3/4" Rigid Conduit, Nylon	.90	0.40
REF-0100C	Rigid Entry Fitting, 1.0" Rigid Conduit, Nylon	.95	0.43
REF-0150	Rigid Direct Bury Entry Fitting for 1.5" Flexworks	2.35	1.06
REF-0200	Rigid Direct Bury Entry Fitting for 2" Flexworks	2.45	1.11
REF-0200F	Rigid Direct Bury Entry Fitting for 2.0" Smith SW FRP	2.45	1.11
REF-0200X	Rigid Direct Bury Entry Fitting for 2" LCX DW FRP	2.45	1.11
REF-0300F	Rigid Direct Bury Entry Fitting for 3" Smith SW FRP	2.85	1.30
REF-4015	FlexWorks Rigid Entry Fitting 4" x 1.5"	2.75	1.25
REF-4015DC*	Double-wall Compatibile (DC) FlexWorks Rigid Entry Fitting 4" x 1.5"	2.75	1.25
REF-4020	FlexWorks Rigid Entry Fitting 4" x 2.0"	2.85	1.30
REF-4020DC*	Double-wall Compatibile (DC) FlexWorks Rigid Entry Fitting 4" x 2.0"	2.85	1.30

*Compatible with any double-wall sump up to 0.52 inches thick.
Ships with customer "acorn nuts" and O-rings to ensure interstice integrity.

Hole-Saw Size Table

Entry Fitting Model #	Hole-Saw Dimension
REF-0075C, REF-0100C	2.5"
REF-0150, REF-0200, REF-0200F, REF-0200X, REF-4015, REF-4020	4"
REF-0300F	5"

Features & Benefits:

- ◆ **Sealing redundancy throughout** – Maximum containment and unmatched protection from water intrusion
- ◆ **Preserves total accessibility** – For monitoring, maintenance, testing and repair
- ◆ **Maintains flexibility** to accommodate pipe and ground movement
- ◆ **Hard-shell exterior** – to weather the elements and abuse of the underground environment

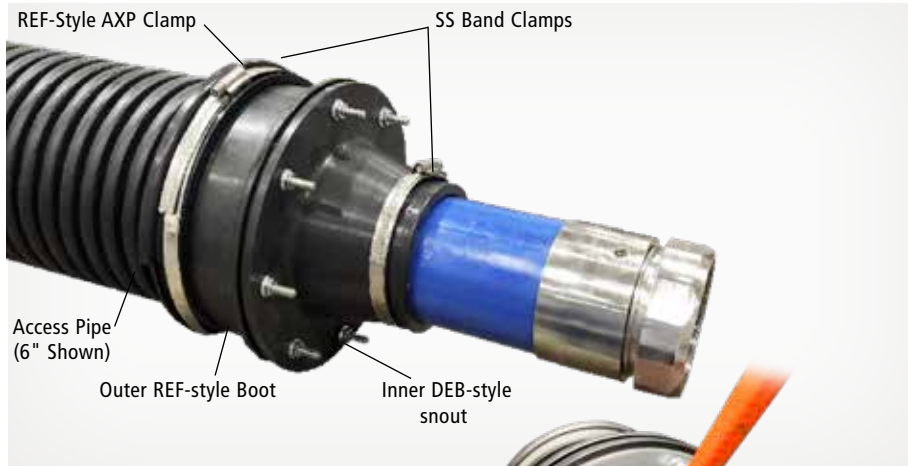

Hybrid Entry Fittings

FlexWorks Hybrid Entry Fittings are designed to seal the sump penetration. These entry fittings bring the best of both worlds from the robust and popular REF and legacy DEB lines of products. The outer buried half features a hard-shell exterior to weather the elements and abuse of the underground environment, the same as you find on an REF. The inner accessible half provides the flexibility of the DEB. The sealing redundancy throughout the fitting provides maximum containment and unmatched protection from water intrusion.



Features & Benefits:

- ◆ Watertight pipe and conduit entries
- ◆ Maximum flexibility to accommodate pipe and ground movement
- ◆ Added flexibility providing quick and easy installation
- ◆ Provides clean, dry environment inside tank and dispenser sumps and accommodates various site installations
- ◆ Allows for easy field adjustments
- ◆ Can be repaired if damaged
- ◆ Internal and external clamps provide dual positive seal-off points
- ◆ Third-party tested and approved by UL/ULC
- ◆ Available heat-trace entry fittings with grommet



HEF-4020G Entry Fitting with Heat Tracing

Ordering Specifications - Hybrid Entry Boot & Fitting

Model #	Application	Hole Saw	
		in.	cm
HEF-0751	1/2", 3/4", and 1" Conduit Hybrid Entry Fitting	2 1/2"	6.35
HEF-4010	4" to 1.0" Hybrid Entry Fitting for 4" Flexworks Access Pipe to 1.0" DW Flexworks Pipe	4"	10.16
HEF-4075	4" to 0.75" Hybrid Entry Fitting for 4" Flexworks Access Pipe to 0.75" DW Flexworks Pipe	4"	10.16
HEF-4015*	4" to 1.5" Hybrid Entry Fitting for 4" Flexworks Access Pipe to 1.5" DW Flexworks Pipe	4"	10.16
HEF-4015A	Hybrid Entry Fitting, 1.5" with Air Stem	4"	10.16
HEF-4015G	Hybrid Entry Fitting, 1.5" with Grommet for Heat Tracing	4"	10.16
HEF-4020*	4" to 2.0" Hybrid Entry Fitting for 4" Flexworks Access Pipe to 2.0" DW Flexworks Pipe	4"	10.16
HEF-4020A	Hybrid Entry Fitting, 2.0" with Air Stem	4"	10.16
HEF-4020G	Hybrid Entry Fitting, 2.0" with Grommet for Heat Tracing	4"	10.16
HEF-6030*	6" to 3.0" Hybrid Entry Fitting for 6" Flexworks Access Pipe to 3.0" DW Flexworks Pipe	5 3/4"	14.61
HEF-4175	4" to 0.75" and 1.0" Hybrid Entry Fitting for Fuel-Oil applications	4"	10.16

* For round-sump compatibility, add the correct ROUNDKIT for your application.

Round-Kit Guide

Original Part #	Plus	Kit for Round Sumps
HEF-4075	+	ROUNDKIT-14
HEF-4010		
HEF-4015(A/G)		
HEF-4020(A/G)		
HEF-4175		
HEF-0150		
HEF-0200		
REF-0150		
REF-0200		
HEF-6030	+	ROUNDKIT-16
HEF-0300		
REF-4015	+	ROUNDKIT-24
REF-4020		

Flexible Entry Boots

FlexWorks Flexible Entry Boots are reliable, safe seals for pipe and conduit entries into underground containment sumps. These entry boots allow for angled pipe entries and have no exposed metal parts to the underground environment. These entry boots are available in a variety of sizes and designs to accommodate rigid and flexible piping, ducting and access pipe.

Features & Benefits:

- ◆ Watertight pipe and conduit entries
- ◆ Installation on flat or round surface
- ◆ Added flexibility permitting angled entries up to 15 degrees

Sump Entry

Flexible entry boots have been tested to withstand a minimum of 6' of liquid head pressure. These seals provide a studded flange connection to create a positive and secure seal where the rubber contacts the sump wall and also around the pipe or conduit. Tightening down on a series of stud fasteners with a compression ring provides a high-compression mechanical seal compared to screw-on-type bulkhead seals.



Primary pipe and access pipe entering the containment sumps may not be perpendicular with the sump wall. Angled entries are generally a result of directional plumbing restrictions on the inside of the containment chamber due to space limitations. Flexible entry boots are flexible enough to permit angled pipe or conduit entries (on two axes) into the sidewall of a containment chamber. All flexible entry boots permit angled entries up to a 15-degree angle off the perpendicular center line in any direction without leaking or putting undue stress on the pipe or conduit seal.

Ordering Specifications - Single Flexible Entry Boot & Fitting

Model #	Application	Weight		Hole Saw	
		lbs.	kg	in.	cm
EBF-0751	1/2", 3/4" and 1" Conduit Entry Boot Fitting	1.2	0.5	2 3/8"	6.03
EBF-0150	1.5" Entry Boot Fitting for 1.5" DW FlexWorks Pipe	1.5	0.7	3 3/4"	9.52
EBF-0200	2" Entry Boot Fitting for 2" DW FlexWorks Pipe or 2" LCX	1.8	0.8	3 3/4"	9.52
EBF-0200F	2" Entry Boot Fitting for 2" Rigid Pipe	1.3	0.6	3 3/4"	9.52
EBF-0300	3" Entry Boot Fitting for 3" DW FlexWorks Pipe or 3" Rigid Pipe/LCX	1.8	0.8	5"	12.7
EBF-0400	4" Entry Boot Fitting for 4" Rigid Pipe/AXP Pipe	2.0	0.9	5 1/2"	13.97
EBF-0600	6" Entry Boot Fitting for 6" Rigid Pipe Saber Saw	3.0	1.3	7 1/4"	18.42
SAB-7400	4" Sump Access Boot – Can be used as a repair boot plug for EBF fittings	2.0	0.9	5"	12.7

Flexible Entry Boot Manual Order Number: EBM-0001

Test Boots

FlexWorks Test Boots are used to isolate and air-test the interstitial space between the primary and secondary pipe. One test boot is required for each pipe end.

The QCJ-2512 and QCT-2512 models allow users to quickly close the interstitial space of the pipe for testing. New EPA regulations maintain that secondarily contained areas must be tested for tightness after repairs and this new hardware saves time and money on labor when tests are necessary.

- QCJ-2512 (Junction) is used for pass-through UDCs, and the QCT-2512 (Termination) is used to terminate the run.
- Quick-close system allows for open systems to be closed and tested in minutes.



Models TBA-3015, TBA-3020, TBA-4015 and TBA-4020



Models TBA-0075, TBA-0100, TBA-0150 and TBA-0200



Test Gauge Assembly (TGA-15)



Test Jumper for Air Stems (TJ-200A)



Test Line Termination Kit for Air Stems (TLT-36A)

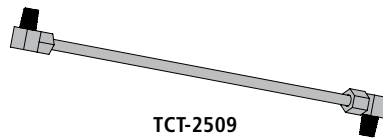

TCT-2509

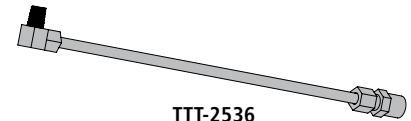

TTT-2536

Ordering Specifications - Test Boot & Testing Equipment

Model #	Application	Weight	
		lbs.	kg
QCJ-2512	Junction Test Kit, Double Wall System		
QCT-2512	Junction Test Kit, Double Wall System		
TBA-0075	3/4" Test Boot with Air Stem	0.20	0.09
TBA-0100	1" Test Boot with Air Stem	0.20	0.09
TBA-0150	1.5" Test Boot with Air Stem	0.35	0.16
TBA-0200	2" Test Boot with Air Stem	0.40	0.18
TBA-0300	3" Test Boot with Air Stem	0.70	0.32
TBA-3015	3" to 1.5" Test Boot with Air Stem	0.35	0.16
TBA-3020	3" to 2" FRP Test Boot with Air Stem	0.40	0.18
TBA-4015	4" to 1.5" Test Boot with Air Stem	0.75	0.34
TBA-4020	4" to 2" Test Boot with Air Stem	0.75	0.34
TBA-4030	4" to 3" FRP Test Boot with Air Stem	0.70	0.32
TJ-200A	Test Jumper for Air Stems		
TLT-36A	Test Line Termination Kit for Air Stems		
TGA-15	Test Gauge Assembly		
TCT-2509	Test Jumper for Double-Wall Coupling (DPC and SBC Series)		
TTE-5	Replacement Brass Elbows for Test Tubes (5 per bag)		
TTT-2536	Test Tube Termination Kit for Double-Wall Coupling (DPC and SBC Series)		



QCJ-2512

Flexible Piping Systems for Fuel Oil & Generator Applications

The FlexWorks Fuel Oil Piping System is designed to provide a reliable fuel-supply system to generators and boilers from remote fuel tanks. Typical applications include both a 3/4" supply and a 1" overflow return line running from a remote AST or UST to a generator engine or boiler day tank. Both lines are typically inserted into a common FlexWorks Access Pipe to provide retractable access to the fuel lines. OPW will cut fuel oil pipe to length at no charge.

HEF-4175 Double Entry Boot Fitting



3/4" Primary Pipe with SBC Fitting



1" Primary Pipe with SBC Fitting

Ordering Specifications Specialty Fittings

Model # Application

PDT-411	4" x 1" x 1" Double Tap Bushing
PTA-4175	Transition Assembly
TBA-4175	4" Fuel Oil Boot Transition Assembly
TBA-4175A	4" Fuel Oil Boot Transition Assembly with Air Stem

Model # Application

SBC-2075	Swivel Bolt-On Coupling 3/4" NPT
SBC-2100	Swivel Bolt-On Coupling 1" NPT

AST APPLICATIONS

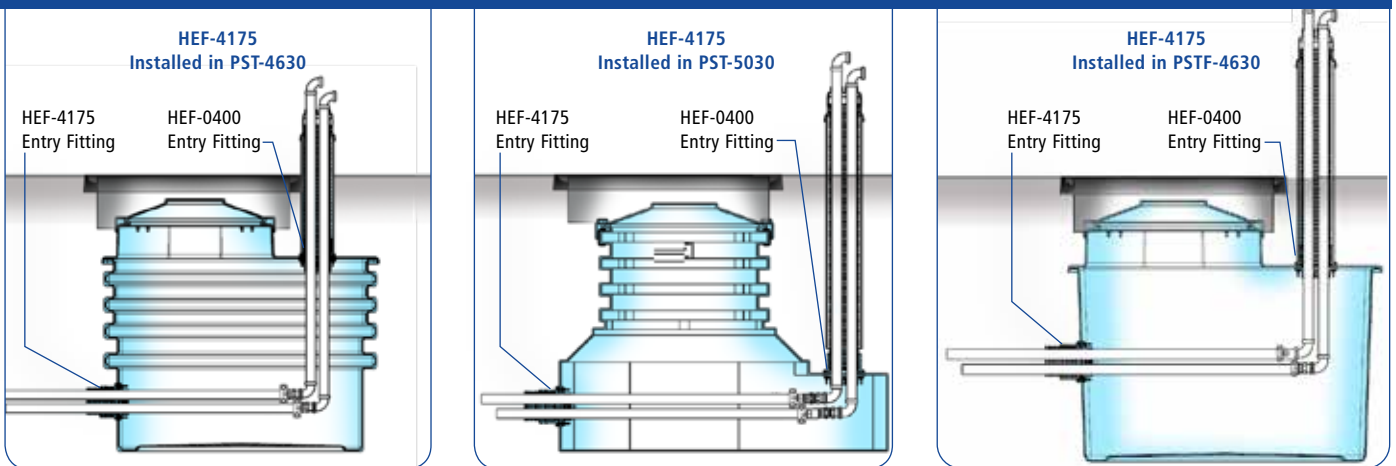

Transition Assembly Specialty Fittings - 3/4" and 1"

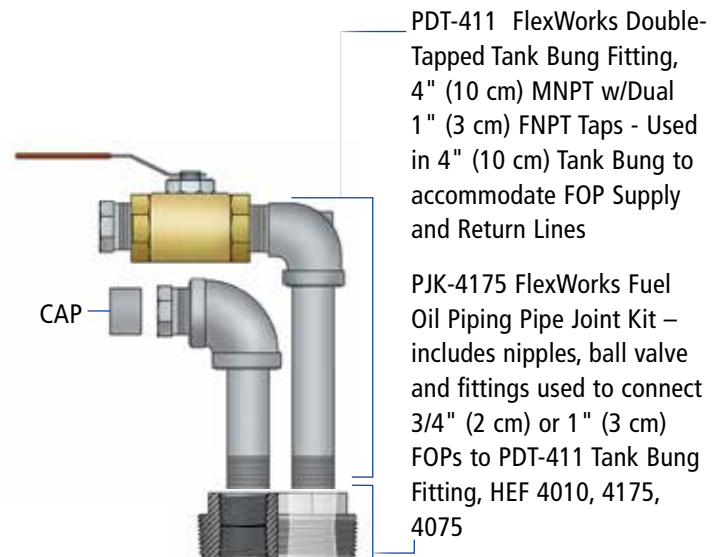
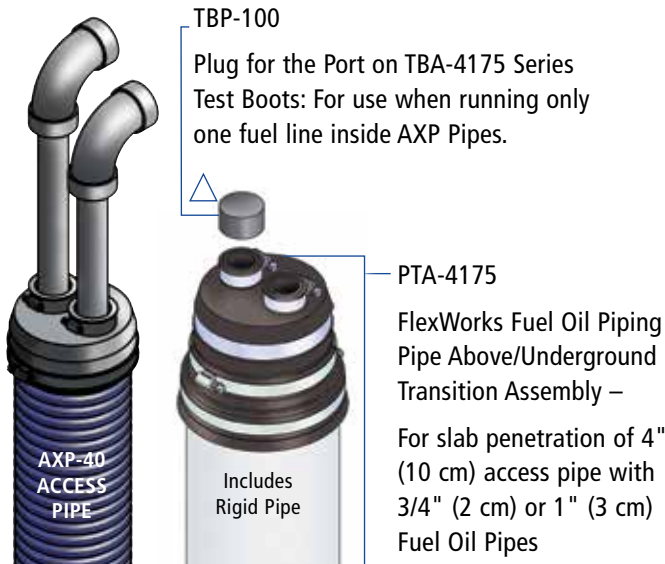

VSE Vent Transition Sump

The new OPW Vent Transition Sump (VSE) is an at-grade system that utilizes the fiberglass DSE Dispenser Sump base with a powder-coated steel top. This laser-cut top features a lockable access hatch and is sloped for water-shedding. Tops arrive configured with up to four (4) pre-cut entry holes for either 2" or 3" vent stacks.

Rigid Entry Fittings (REF) are included for the vent stack entries, along with UV/ weather-resistant caps for protection. A vent stack rack system is available in units of 4 feet up to 12 feet total.

The smooth walls inside and out of the DSE base allow for a more secure bond of the pipe entry fittings. See the chart below for available OPW Vent Transition System components for more efficient installs and superior quality.

The VSE Includes:

- ◆ Fiberglass DSE Base
- ◆ 14-Gauge Powder-Coated Steel Top
- ◆ Desired Configuration of Vent Stack Entries with REF Fittings and UV/ Weather-Protection Caps



VSE Vent Transition Sump (with rack system)



OPW Vent Transition System

Features & Benefits:

- ◆ **Powder-Coated Steel Tops** – long-lasting, lockable, less heat absorption, and water-shedding performance. Rigid entry fittings included with UV / weather-resistant protective caps
- ◆ **Fiberglass DSE Base** – advanced composite technology provides smooth surfaces on both sides of the sump walls to create consistent thickness and shape for strong bonds with entry fittings
- ◆ **Any Pipe, Any Fittings** – sump base is compatible with all vent pipe and entry fittings.
- ◆ **Customizable** – Steel tops are pre-configured to arrive laser-cut with up to four (4) vent stack entries at either 2" or 3"
- ◆ **Peace-of-Mind Installations** – Tested, quality products that are designed to install faster and perform over time
- ◆ **Vent Transition System** – Combine with OPW's vent pipe, PV vents, and other components for superior performance, cost savings, and enhanced efficiency of installs
- ◆ **Tops can be ordered separately** – if stocking DSE bases

Part Number Configuration Guide

VSE - _ _ _ _ Dashes represent the sizes of vent stack entries, determined from left to right. (Up to 4 entries. Entry sizes 2" or 3")

To order Tops separately, follow above method using part number **VSE-TOP**-_ _ _ _

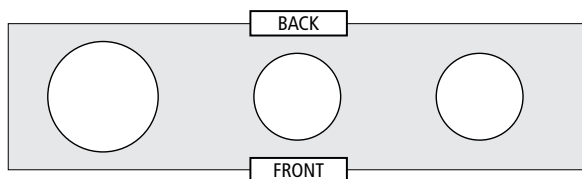

Example A:
VSE-322 = (3) entries total. (1) 3" diameter and (2) 2" diameter

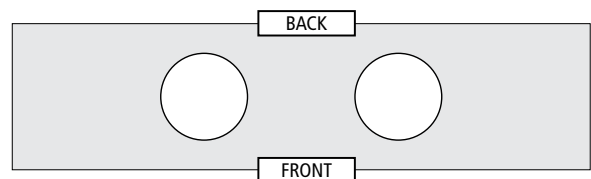

Example B:
VSE-22 = (2) entries total, both 2" diameter

Vent Stack Modular Rack System	VSR-4: 4ft VSR-8: 8ft VSR-12: 12ft
---------------------------------------	--

Pipe clamps for vent stacks purchased separately.	
218384	2" pipe clamp
218385	3" pipe clamp

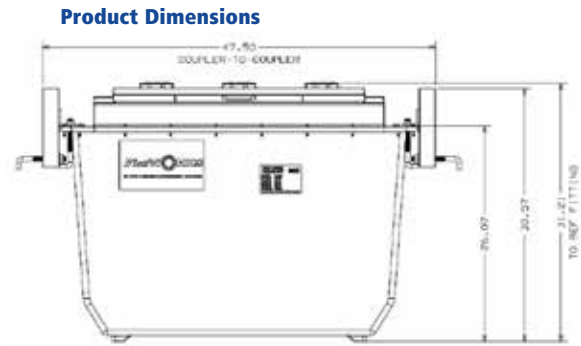

- 47.50" COUPLER-TO-COUPLER
- 31.21" TO REF FITTINGS
- HEIGHT: 30.57"
- WIDTH: 32.50"

VSE & VSR Replacement Parts

Part Number	Description
REF-0200V	RIGID ENTRY FITTING, 2.0" SINGLE WALL FRP, 2" REF cover, VSE
REF-0300V	RIGID ENTRY FITTING, 3.0" SINGLE WALL FRP, 3" REF cover, VSE
218212	2" REF Cover
218356	3" REF Cover
215926	Top Installation Kit
H13190	Anchor bolt kit
218255	SQ TUBE, RACK
218257	STRUT
218256	Coupler
218437	Hardware kit base
218438	Hardware kit extension



Available OPW Vent Transition System Components

Pressure Vacuum Vents	623V-2203 2" Thread-On NPT 623V-3203 3" Thread-On NPT	723V-2203 2" Thread-On NPT. CARB EVR 723V-3203 3" Thread-On NPT. CARB EVR
OPW FlexWorks Vent Pipe	V20 2" Double-Wall Vent Pipe	V30 3" Double-Wall Vent Pipe
Pipe Couplings	DPC-2200A 2" Double-Wall Swivel DPC-2300A 3" Double-Wall Swivel	SBC-2200 2" Swivel Bolt-On (NPT)
Entry Fittings (for DSE sump)	REF-0200 2" Rigid Entry Fitting HEF-0200 2" Hybrid Entry Fitting HEF-6030 3" Hybrid Entry Fitting	
Elbows	SEF-2020 2" Elbow, 2" Female NPT to 2" Male NPSH SEF-3030 3" Elbow, 3" NPSH x 3" NPT	



GSE Grade-Level Transition Sump

The new OPW GSE Grade-Level Transition Sump is an at-grade system that utilizes the fiberglass DSE base with a powder-coated steel top. The top features a lockable access hatch and is sloped for water-shedding.

The smooth walls inside and out of the DSE base allow for a more secure bond with pipe entry fittings.

The GSE is an ideal transition sump for aboveground storage tank (AST), aviation, marina, fuel oil and generator applications. It can also serve as a multi-purpose junction box for various fuel, chemical, water and electrical installations.

The GSE Includes:

- ◆ Fiberglass DSE Base
- ◆ 14-Gauge Powder-Coated Steel Top



GSE Grade-Level Transition Sump

Features & Benefits:

- ◆ **Fiberglass DSE Base** – advanced composite technology provides smooth surfaces on both sides of the sump walls to create consistent thickness and shape for strong bonds with entry fittings. This is a multi-purpose base and is the same one used for dispenser and vent transition applications. It is completely stackable, nestable and easily separated to maximize warehouse and job-trailer space. One base – many functions!
- ◆ **Powder-Coated Steel Tops** – long-lasting, lockable, less heat absorption and water-shedding performance
- ◆ **Any Pipe, Any Fittings** – sump base is compatible with all pipe and entry fittings
- ◆ **Peace-of-Mind Installations** – Tested, quality products that are designed to install faster and perform over time
- ◆ **GSE Tops can be ordered separately** – for those who stock DSE bases
- ◆ **Versatile Transition Sump** – multiple applications as a transition or junction box, including AST, aviation, marina, fuel oil, generator, chemical, water and electrical

Part Numbers	
GSE-3344	GSE Steel Top with DSE Base
GSE-TOP	GSE Steel Top
DSE-BASE	DSE Base

Product Dimensions

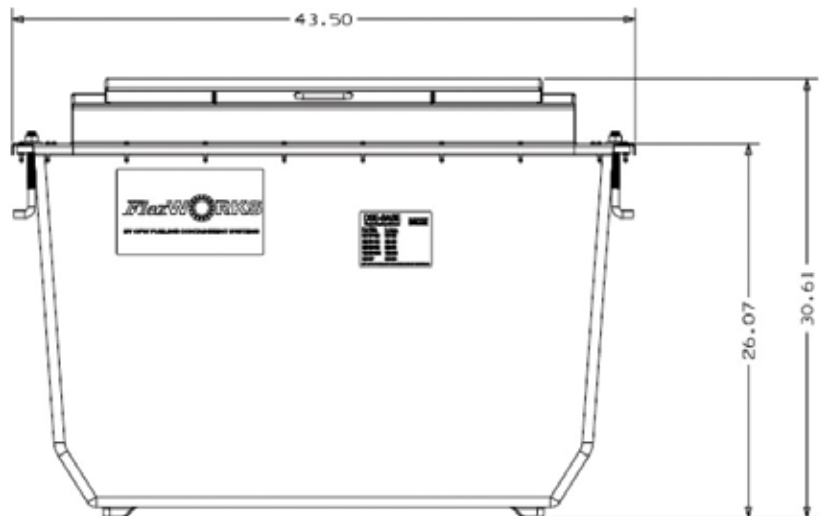

Total: 43.5" length x 32.5" width

Transition Sumps

FlexWorks Above-Grade/Below-Grade Transition Sumps

Model PSTF-4630 Transition Sump (Fiberglass Sump/Fiberglass Top)

- ◆ Large, injection-molded FRP containment chambers are stackable for convenient shipping and storage
- ◆ Removable FRP top allows maximum access during installation of fittings and equipment, and provides a rigid entry fitting area adjacent to the cover for vertical entry of above-grade piping
- ◆ The PSTF-4630 is not adjustable, but FRP Sump Height Extenders (DSFE-4612) are available for the PSTF-4630 to accommodate deeper-bury applications

Model PSTF-4630 Transition Sump (Fiberglass Sump/Fiberglass Top)

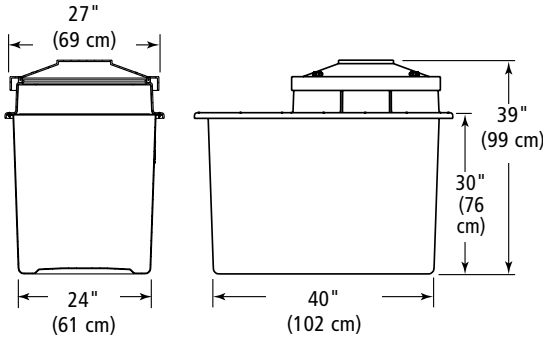

Model PST-4630 Transition Sump (Polyethylene Sump/Fiberglass Top)

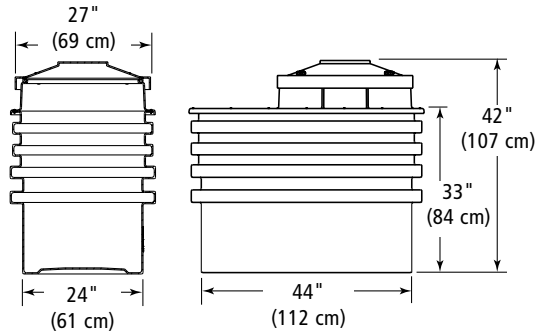

Model PST-4630 Transition Sump (Polyethylene Sump/Fiberglass Top)

- ◆ Large, heavily ribbed polyethylene containment chamber provides structural rigidity
- ◆ Adjustable to a minimum of 26"

Model PST-5030 One-Piece Polyethylene Transition Sump

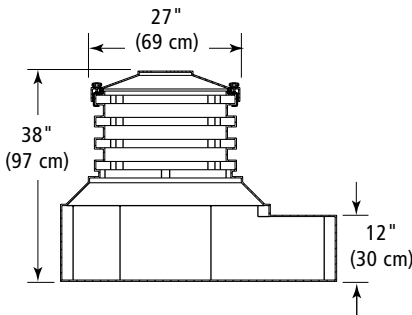

Model PST-5030 One-Piece Polyethylene Transition Sump

- ◆ Flat entry fitting area extending from the sump base accommodates vertical pipe entries
- ◆ Heavily ribbed riser provides strength and rigidity
- ◆ Adjustable to a minimum of 29"

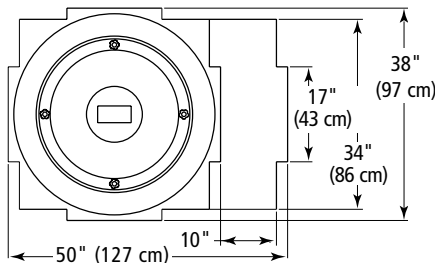

Replacement Parts

Part #	Description
H13257M	Knob (each)
H13971	Knob Kit (6 Pack)
H13426M	27" Seal
D02095M	27" Poly Cover
DSC-4021B	Top Assembly for PTS-4021

Ordering Specifications - Specialty Fitting

Model #	Application	Height		Weight	
		in	cm	lbs	kg
PSTF-4630	Fiberglass Transition Sump with Fiberglass Top, Poly Cover	39	99	90	41
PST-4630	Poly Transition Sump with Fiberglass Top, Poly Cover	42	107	100	45
PST-5030	One-Piece Poly Transition Sump with Poly Top, 38" x 50"	38	97	100	45
PTS-4021	Two-Piece Poly Transition Sump with Poly Top	46.5	118	110	49
DSFE-4612	Fiberglass Sump Extension	12	31	25	11

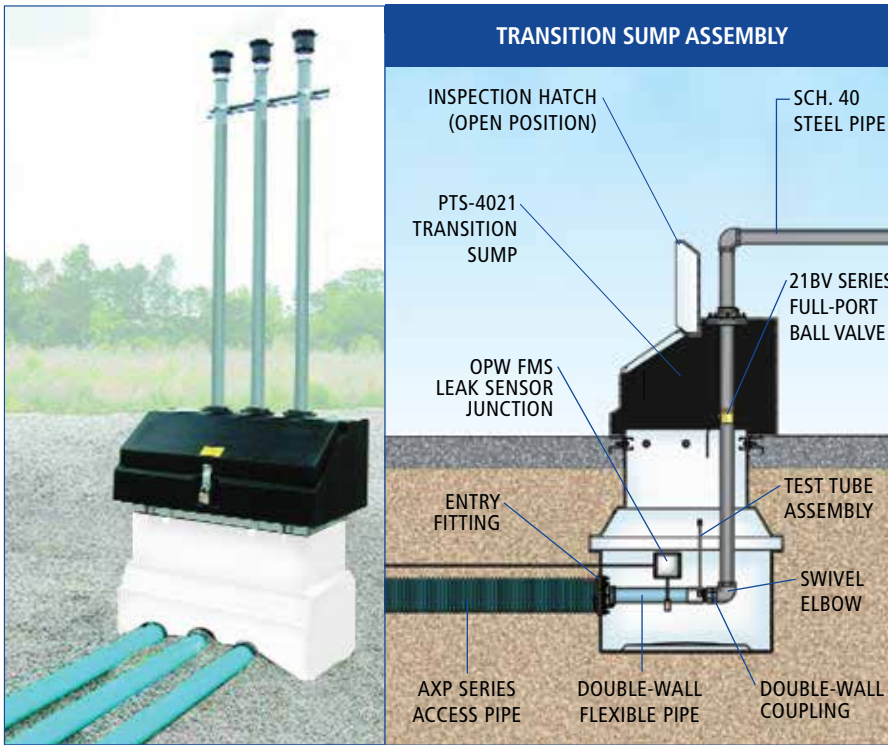

Transition Sumps

Model PTS-4021 Transition Sump
 (2 Piece - Polyethylene Sump/
 Polyethylene Top)

- ◆ Non-corroding, polyethylene sump container
- ◆ Weatherproof lockable cover
- ◆ Exterior anchoring system

AST Application: Provides secondary containment and accessibility to the fittings that connect the underground supply piping to the rigid supply piping that leads from an aboveground storage tank.

Vent Stack Application: Transition sump is used for containment and accessibility to the fittings. At the vent stack, where the underground vent piping connects to the rigid vent stack piping.

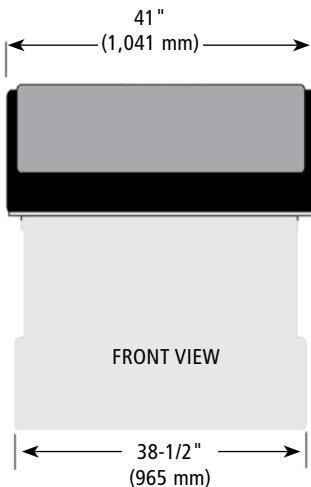
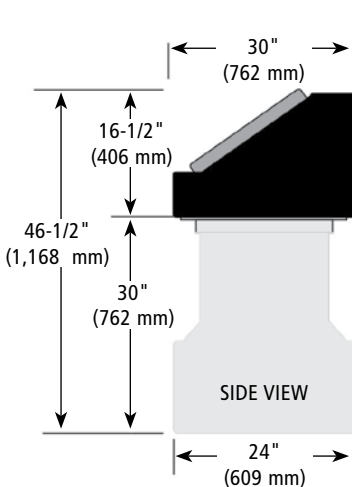
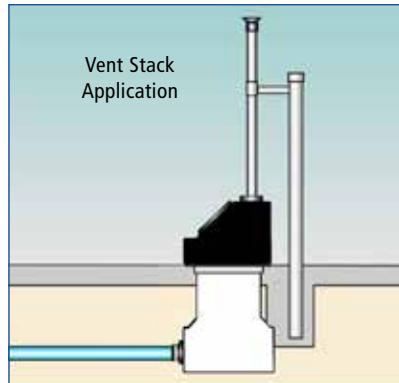
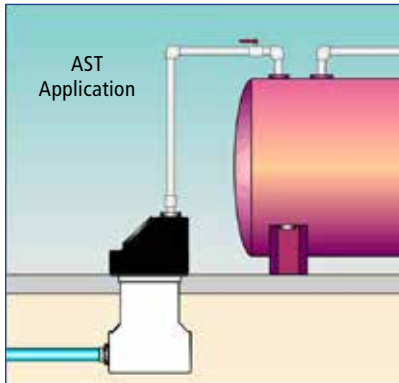

The complete Environmental System for underground fuel transfer and containment for the 21st century.

Special Application Sumps & Extensions

FlexWorks Special Application Sumps are installed below-grade and provide a convenient means of housing a multitude of underground piping connections and equipment, including valves, filters, meters and pumps. The PSL-3830 Line Connection Sump has large horizontal flats to accommodate multiple piping entries. The PSL-3630 Tall Mini-Sump has long vertical flats to accommodate applications with varying pipe entry heights. The PSL-2430 Mini-Sump is ideal for connecting long pipe runs in a contained area.



PSL-3830



PSL-3630



PSL-2430

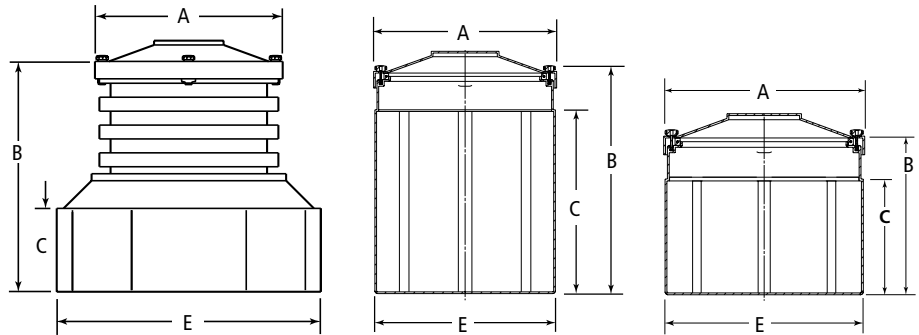

Ordering Specifications - Polyethylene Tank Sumps (with Compression Fit Covers)

Model #	Application	Manway Dia.		Dimensions						# of Panels	E Base		Burial Depth				Weight	
				A Cover		B Height		Dimensions CXE					max.	min.				
				in.	mm	in.	mm	in.	mm				in.	mm	in.	mm		
PSL-2430	Special Application Sump, 24" x 30"	30	762	27	686	24	610	16 x 10	406 x 254	8	26	660	36	914	26	660	36	16
PSL-3830	In-Line Sump, 38" x 30"	30	762	27	686	63	1,600	12 x 38	305 x 965	12	38	965	41	1041	29	737	85	38
PSL-3630	Special Application Sump, 36" x 30"	30	762	27	686	36	914	28 x 20	711 x 508	8	26	660	48	1219	40	1016	42	19

Replacement Parts

Part #	Description
D02095M	27" Poly Cover
H13426M	27" Seal
H13257M	Knob (each)

Emergency Shut-Off & Vapor-Line Shear Valves



Emergency Shut-off Valves.....	59 - 62
Vapor-Line Shear Valves	63 - 64
DEF Shear Valve	65
Island Forms & Protective Curbing	66 - 69
Flexible Connectors	70 - 71
Suction-System Accessories	72

10 Plus Series Emergency Shut-Off Valves

OPW raised the protection standard in emergency valves when it introduced the first double-poppet valve back in 1989. This industry-changing OPW innovation helped to significantly reduce the risk of fire, explosion, personal injury, property damage and environmental contamination at sites around the world. Major oil companies and jobbers agreed that providing added protection for their customers, investments and the environment were the three most convincing reasons for switching to the innovative new valves.

Dimensions

	1.5 in.	2.0 in.
A	7 ⁹ / ₁₆	8 ⁷ / ₈
B	2 ²⁵ / ₃₂	3 ¹ / ₂
C	2 ²¹ / ₃₂	
D	2 ¹¹ / ₁₆	3 ¹ / ₂
E	2 ⁹ / ₁₆	3 ³ / ₁₆
F	4 ²¹ / ₃₂	5 ³¹ / ₃₂

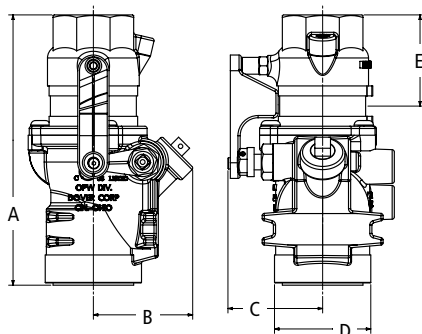
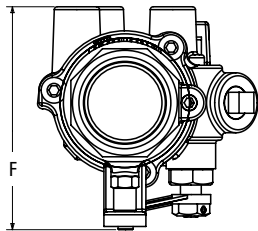

Listings and Certifications



10 Plus Series Instruction Sheet Order Number: 201614

Materials

Top: Cast iron
Body: Cast iron



Features

- ◆ The ONLY emergency shut-off valve in the world designed to protect your customers, investments, and the environment against the potential hazards of undetected shear-groove leaks caused by low-impact incidents
- ◆ The patented SmartGuard™ design contains shear-groove leaks, preventing fuel from leaking into sumps to help reduce the risk of fire, explosion, personal injury, property damage, environmental contamination, product loss and costly clean-up
- ◆ Superior shear-groove design and engineering results in reliable valve shut-off in the event of a pull-over or dislodged dispenser. The 10 Plus utilizes the same time-tested field-proven design of the OPW 10 Series Emergency Shut-off Valve – the most specified emergency shut-off valve in the world
- ◆ Fusible link releases to automatically close the valve to reduce fire hazard
- ◆ Rigorously tested to meet OPW's rigid quality standards
- ◆ Renewable Fuel (RF) Shear Valve Option E85 Compatible

Ordering Specifications

Model #	Body Size		Body Weight		Connection Threads	Poppet Configuration	Application	Mounting System
	in.	cm	lb.	kg				
10P-0150	1 1/2	4	6.7	3.05	NPT	Single	Pressure	Combination
10P-0150RF*	1 1/2	4	6.7	3.05	NPT	Single	Pressure	Combination
10P-0152	1 1/2	4	6.8	3.10	NPT	Double	Pressure	Combination
10P-0152RF*	1 1/2	4	6.8	3.10	NPT	Double	Pressure	Combination
10P-0200	2	5	11.2	5.12	NPT	Single	Pressure	Plate Mounted
10P-0200RF*	2	5	11.2	5.12	NPT	Single	Pressure	Plate Mounted
10P-0202	2	5	11.2	5.12	NPT	Double	Pressure	Plate Mounted
10P-0202RF*	2	5	11.2	5.12	NPT	Double	Pressure	Plate Mounted

*RF designates renewable fuel E85/B100 applications



10 Plus Replacement Parts

Part #	Description
10RPLUS-0150	10 Plus 1.5" Single Poppet Replacement Top
10RPLUS-0152	10 Plus 1.5" Double Poppet Replacement Top
10RPLUS-0200	10 Plus 2" Single Poppet Replacement Top
10RPLUS-0202	10 Plus 2" Double Poppet Replacement Top
202950	1 1/2" Tetra Seal
200143	Safety Hub/Fusible Link
213273	E85 Safety Hub S/A Orange
H11361M	2" Tetra Seal

Materials

- Top:** Cast iron
- Body:** Cast iron
- Disc:** M-19
- Carrier:** Zinc-plated steel
- Stem:** Copper-nickel-chrome-plated brass
- Poppet Spring:** Stainless-steel
- Seal:** M-19 O-Ring
- Packing nut:** Brass, Teflon®-coated
- Inlet and outlet thread: 1-1/2" (4 cm) NPT (British threads available)
- *With black Duragard® E-Coating

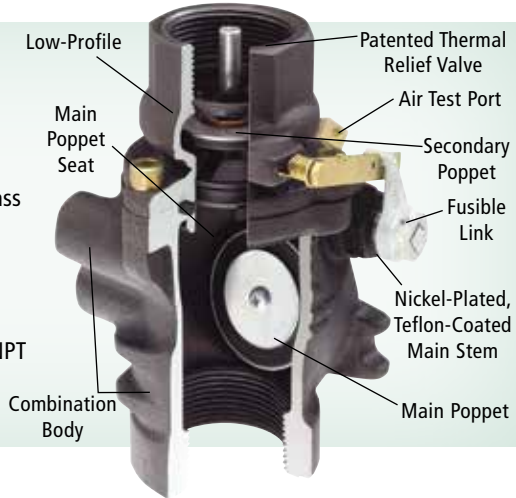

10 Series Emergency Shut-Off Valves

OPW 10 Series Emergency Shut-off Valves are installed on fuel-supply lines beneath dispensers at grade-level to minimize hazards associated with collision or fire at the dispenser. If the dispenser is pulled over or dislodged by collision, the top of the valve breaks off at the integral shear groove, activating poppets and shutting off the flow of fuel. Single-poppet models shut off supply flow, while double-poppet models shut off supply as well as prevent release of fuel from the dispenser's internal piping. The base of the emergency valve is securely anchored to the concrete dispenser island through a stabilizer bar system within the dispenser sump or pan to ensure proper shearing action. The valve base is secured to the stabilizer bar using a three-point boss mount system or a U-Bolt Kit (not included) 10UBK-015 (1-1/2") and 10URK-0200 (sold separately). Valve inlet (bottom) connections are female pipe threads and outlet (top) connections are available with female threads, male threads or a union fitting. Other options include suction system models with a normally closed secondary poppet which maintains prime, and models with external threads on the inlet body which connect to secondary-containment systems.

Features

- ◆ **High Flow Capacity** – the primary poppet is held out of the flow stream while the secondary poppet is held normally open to minimize head loss across the valve and to protect the poppet seals from damage and erosion. True 1-1/2" (4 cm) and 2" (5 cm) body sizes ensure maximum flow.
- ◆ **Fire Protection** – a fusible link trips the valve closed at 165° F (74°C) to shut off fuel supply to the dispenser.
- ◆ **Main Poppet Seat Integral to the Top Assembly** – having the main poppet seat as an integral part of the valve top ensures a new, clean seating surface is installed each time the top is replaced. This design also ensures that the integrity of the seal between the valve top and bottom is verified during line testing and allows full inspection of the main poppet when the top is removed.
- ◆ **Duragard®-Coat Finish** – provides superior corrosion resistance.
- ◆ **Reliable Shut-off** – a stainless-steel main spring, a Teflon®-coated brass packing nut and a copper/nickel/chrome-plated brass stem are designed to prevent tar build-up and corrosion from interfering with poppet operation after long periods of normal service without activation.
- ◆ **Integral Test Port** – a 3/8" (9.5 mm) test port allows the piping system to be air-tested without breaking any piping connections.
- ◆ **Patented Thermal Relief Valve** – relieves excessive pressure over 25 psi caused by thermal expansion of fuel in the dispenser piping system in the event of fire (double-poppet models only).
- ◆ **Low-Profile Tops** – female and union-top double-poppet valves have a low-profile top to allow upgrading from OPW single-poppet valves without changing existing piping.
- ◆ **Multiple Mounting Options** – valves are boss-mounted to stabilizer bars in sumps and pans or mounted to bars embedded in the island with optional U-Bolt kits 10UBK-015 (not included). Versatile Combination Body (boss mount/ U-Bolt mount) models are available to accommodate most mounting applications with one valve style.
- ◆ **Underwriters Laboratories** –  listed for use with gasoline and 85% and 100% methanol. All OPW 10 Emergency Shut-Off Valves meet requirements of UL STANDARD 842.

PA15 Offset Adaptor

The OPW PA15 Offset Adaptor is designed for adjusting misaligned pipes in dispenser sumps and suction stubs. The PA15 has a low-profile feature, and is designed for maximum flow.



Materials

Ductile Iron
Black Duragard®
E-Coating

Ordering Specifications

Part #	Thread Size		Offset		Height		Width		Body Weight	
	in.	mm	in.	mm	in.	mm	in.	mm	lb.	kg
PA15-15	1 1/2	38.1	1 1/2	38.1	2 1/4	57.2	4 1/8	104.8	2	.9
PA15-20	1 1/2	38.1	2	51	2 1/4	57.2	4 5/8	117.5	2	.9

OPW 10 Series Emergency Shut-Off Valves

Ordering Specifications

Female-Threaded Top (Outlet) Connection Valves

Model #	Body Size		Connection Threads	Poppet Configuration	Application	Replacement Top
	in.	cm				
10BF-5725	1½	4	NPT	Single	Pressure	10RFT-5750
10BFP-5726	1½	4	NPT	Double	Pressure	10FTP-5701
10RF-2001	2	5	NPT	Single	Pressure	10RFT-5742
10RFP-2002	2	5	NPT	Double	Pressure	10RFTP-5752

Male-Threaded Top (Outlet) Connection Valves

Model #	Body Size		Connection Threads	Poppet Configuration	Application	Replacement Top
	in.	kg				
10BM-5825	1½	4	NPT	Single	Pressure	10RMT-5850
10BHMP-5830	1½	4	NPT	Double	Pressure	10RMTP-5851
10SBHMP-5830	1½	4	NPT	Double	Suction	10SHMTP-5811
10RM-2003	2	5	NPT	Single	Pressure	10RMT-5842
10RMP-2004	2	5	NPT	Double	Pressure	10RMTP-5852

Union-Top (Outlet) Connection Valves

Model #	Body Size		Connection Threads	Poppet Configuration	Application	Replacement Top
	in.	kg				
10BU-5925	1½	4	NPT	Single	Pressure	10RUTC-5975
10BUP-5926	1½	4	NPT	Double	Pressure	10UTCP-5901
10SBUP-5926	1½	4	NPT	Double	Suction	10SUTCP-5911
10RU-2005	2	5	NPT	Single	Pressure	10RUTC-5962
10RUP-2006	2	5	NPT	Double	Pressure	10RUTCP-5972

NOTE: All BSPP Thread Shear Valves must be ordered through OPW's Europe or Asia office.

IMPORTANT NOTICE:

When mounting the OPW 10 Series Emergency Shut-off Valves, the anchoring system employed must withstand a force greater than 650 ft. pounds per valve. NFPA Code 30A, Automotive and Marine Service Station Code, requires that the automatic closing feature of emergency shut-off valves be checked at least once per year by manually tripping the hold-open linkage. OPW recommends the use of the FlexWorks Stabilizer Bar Support System for proper mounting of 10 Series Valves.

NOTICE:

As per NFPA 30A, electrical supply to the submersible pump must always be disconnected before servicing meters, dispensers or emergency shut-off valves.

Replacement Valve Tops

Model #	Body Size		Connection Threads	Poppet Configuration	Application	Top Connection	Profile
	in.	cm					
10RFT-5750	1½	4	NPT	Single	Pressure	Female	
10RFTP-5751	1½	4	NPT	Double	Pressure	Female	
10FTP-5701	1½	4	NPT	Double	Pressure	Female	Low-Profile
10RMT-5850	1½	4	NPT	Single	Pressure	Male	
10RMTP-5851	1½	4	NPT	Double	Pressure	Male	
10SHMTP-5811	1½	4	NPT	Double	Suction	Male	
10RUTC-5975	1½	4	NPT	Single	Pressure	Complete Union	
10UTCP-5901	1½	4	NPT	Double	Pressure	Complete Union	Low-Profile
10RFT-5742	2	5	NPT	Single	Pressure	Female	
10RFTP-5752	2	5	NPT	Double	Pressure	Female	
10RMT-5842	2	5	NPT	Single	Pressure	Male	
10RMTP-5852	2	5	NPT	Double	Pressure	Male	
10RUTC-5962	2	5	NPT	Single	Pressure	Complete Union	
10RUTCP-5972	2	5	NPT	Double	Pressure	Complete Union	

1½" Dimensions

	10BF		10BFP 10SBFP		10BM		10BHMP 10SBHMP		10BU		10BUP 10SBUP	
	in.	mm	in.	mm	in.	mm	in.	mm	in.	mm	in.	mm
A	6 ²¹ / ₆₄	161	6 ²¹ / ₆₄	161	6 ¹³ / ₁₆	173	7 ¹¹ / ₁₆	195	7 ¹ / ₄	184	7 ¹ / ₄	184
B	2 ³ / ₄	70	2 ³ / ₄	70	2 ³ / ₄	70	2 ³ / ₄	70	2 ³ / ₄	70	2 ³ / ₄	70
C	2 ¹¹ / ₁₆	69	2 ¹¹ / ₁₆	69	2 ¹¹ / ₁₆	69	2 ¹¹ / ₁₆	69	2 ¹¹ / ₁₆	69	2 ¹¹ / ₁₆	69
D	1 ³ / ₄	44	1 ³ / ₄	44	2 ¹ / ₄	57	3 ¹ / ₈	79	2 ¹¹ / ₁₆	69	2 ¹¹ / ₁₆	69

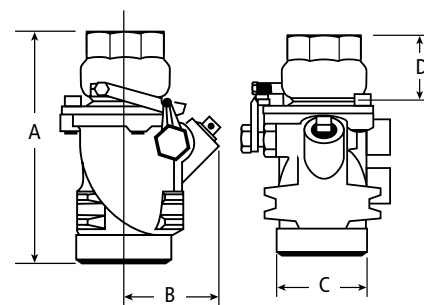

2" Dimensions

	10RF 10RFS		10RM 10RMS		10RU 10RUS		10RFP 10RFSP		10RMP 10RMSP		10RUP 10RUSP	
	in.	mm	in.	mm	in.	mm	in.	mm	in.	mm	in.	mm
A	8 ³ / ₈	213	9 ²⁷ / ₃₂	250	9 ¹³ / ₃₂	239	8 ³ / ₈	213	9 ²⁷ / ₃₂	250	9 ¹³ / ₃₂	239
B	3 ⁷ / ₆₄	79	3 ⁷ / ₆₄	79	3 ⁷ / ₆₄	79	3 ⁷ / ₆₄	79	3 ⁷ / ₆₄	79	3 ⁷ / ₆₄	79
C	3 ¹ / ₄	83	3 ¹ / ₄	83	3 ¹ / ₄	83	3 ¹ / ₄	83	3 ¹ / ₄	83	3 ¹ / ₄	83
D	3 ¹ / ₁₆	78	4 ⁹ / ₁₆	116	3 ⁷ / ₈	98	3 ¹ / ₁₆	78	4 ⁹ / ₁₆	116	3 ⁷ / ₈	98

Other Replacement Parts

Part #	Description
202950	1½" Tetra Seal
H11361M	2" Tetra Seal
H07659M	Link Spring
H07643RB	Link Retaining Screw
H04788M	Hold-Open Link (Brass)
H05361	Safety Hub S/A-Fusible Link
10UBK-015	U-Bolt Kit for 1½"
10URK-020	U-Bolt Kit for 2"

Materials

Body: Cast iron with black Duragard® E-coating

Discs: M-19 Viton®

60VP-1001



Features

- ◆ 1" Female Connection to Both Dispenser and Underground Piping
- ◆ Multiple Mounting Methods – mounting boss accepts either U-Bolt or Straight-Bolt mounting kits.
- ◆ Duragard® E-Coat Finish – provides superior corrosion resistance.

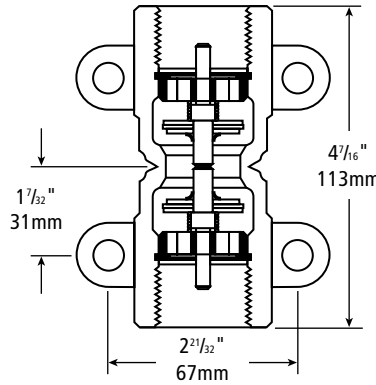

OPW 60V Series Vapor-Line Shear Valves

OPW 60VP-1001

Poppeted Vapor Saver

- ◆ Double-poppeted design incorporated to help prevent vapor loss in the event dispenser is toppled
- ◆ CARB-approved
- ◆ UL-listed 

OPW 60VSP-1001

Poppeted Vapor Saver

- ◆ Double-poppeted design incorporated to help prevent vapor loss in the event the dispenser is toppled
- ◆ CARB-approved
- ◆ UL-listed 
- ◆ 60VSPC-1001 features additional external threads on valve outlet for connection to a secondary-containment system

Ordering Specifications

Product #	Connections	Poppeted
60V-1000	1" x 1" (3 x 3 cm) FNPT	
60VP-1001	1" x 1" (3 x 3 cm) FNPT	•
60VK-1002	U-Bolt Mounting Kit Includes: (2) 3/8" (9.5 mm) U-bolts, (4) washers, (4) nuts	
60VK-1003	Straight Bolt Mounting Kit Includes: (4) 3/8" (9.5 mm) 16 bolts, (4) washers, (4) nuts	

60V Instruction Sheet
Order Number: **H12133M**

OPW 60VS-1000 Line Saver

- ◆ Shear section breaks on impact to minimize damage to underground piping.

OPW 60V-1000 Line Saver

- ◆ Shear section breaks on impact to minimize damage to underground piping.

OPW 60VS Series Vapor-Line Shear Valves

OPW 60 Series Vapor-Line Shear Valves are installed on vapor-return lines beneath dispensers at grade-level to minimize hazards associated with collision or fire at the dispenser. If the dispenser is pulled over or dislodged by collision, the top of the valve breaks free at the integral shear groove to minimize damage to the dispenser piping. Poppeted models afford additional protection by preventing the release of vapors from the dispenser's internal piping and the vapor line to the tank. The base of the Vapor-Line Shear Valve is securely anchored to the concrete dispenser island through a stabilizer bar system within the dispenser sump or pan while the valve top is secured to the dispenser structure to ensure proper shearing action. OPW Vapor-Line Shear Valves are designed to meet the requirements of NFPA-30A Section 4-3.7. Poppeted models are UL-listed and CARB-approved.

Materials

Body: Cast iron with black Duragard® E-Coating

Discs: M -19 Viton®



60VSPC-1001

Features

- ◆ 1-1/2" female connection to underground piping.
- ◆ 1" female connection to dispenser piping.
- ◆ Air-test port to enable vapor-line testing without breaking pipe connections.
- ◆ Choice of top or side inlet connection.
- ◆ Three-Point Boss Mount stabilizer bar lower mounting connection; U-Bolt upper mounting connection.

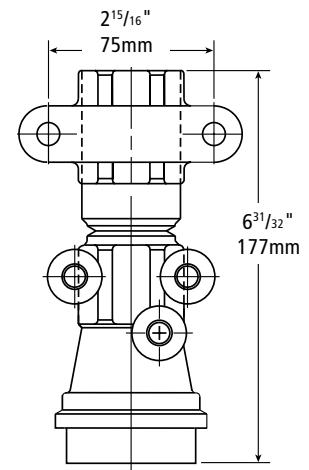

Ordering Specifications

Product #	Connections	Poppeted	Containment Threads
60VS-1000	1" x 1 1/2" (3 x 4 cm) FNPT		
60VSP-1001	1" x 1 1/2" (3 x 4 cm) FNPT	•	
60VSPC-1001	1" x 1 1/2" (3 x 4 cm) FNPT	•	•
60VSK-1002	Mounting Kit Includes: (2) Lockwashers, (2) Nuts, (3) Hex Screws, (3) Washers		

60VS Instruction Sheet
Order Number: H12291M

Listings and Certifications



Materials

Body: Stainless-Steel
Discs: M -19 Viton®

60V-DEF-SS



60V-DEF-SS Stainless-Steel Diesel Exhaust Fluid (DEF) Shear Valve

Starting with 2010 models, DEF is required in diesel-powered trucks utilizing Selective Catalytic Reduction (SCR) to meet federal emissions standards. The dispensing infrastructure at travel centers and fleet-refueling sites continues to evolve as DEF-compatible equipment is installed.

OPW's new 60V-DEF-SS Shear Valve body is made of 100% stainless construction, for unmatched compatibility. This double-poppet shear valve is third-party tested to ensure compatibility with the ISO 22241 Standard. With NPT connections on the top and bottom of the valve, our 60V-DEF-SS valve provides peace of mind and minimizes damage to your DEF-dispensing equipment in the case of impact collision, while preventing product loss.

Features & Benefits:

- ◆ Proprietary design of fully stainless-steel valve-body construction
- ◆ Utilizes a 1" NPT Connection on the top and a 1.5" on the bottom for easy installation with a DEF-approved thread sealant
- ◆ PEI RP1100-recommended materials used for double-poppet internals to contain product in the event of impact collision
- ◆ Machined shear groove for reliable shear performance
- ◆ Standard OPW mounting design, to be installed with any of our Stabilizer Bar Kits (SBK)
- ◆ Loop body version is designed to include easy use with DEF-recirculation systems.

Ordering Specifications

Product #	Connections	Poppeted
60V-DEF-SS	Stainless-Steel DEF Valve with 1.5" NPT lower connection and 1" NPT upper connection	✓

See DEF Loop Product Page 32 for additional information on DEF Loop Shear Valves

Adaptors Available For Installation Flexibility

Product #	Description
205899	1" Male BSPP Adaptor
205900	1" Female NPT Adaptor



Model 205899

Model 205900

OPW Island Forms & Protective Curbing

OPW is the world leader in commercial and industrial protective curbing products. The company designs, engineers and manufactures island forms, curb fascia and pipe to meet virtually any protective curbing application.

OPW Island Forms Feature:

- ◆ **Variety of End Sections, Lengths, Widths and Styles** – allows for a customized fit to site constraints and requirements.
- ◆ **Spacious Mid-Section** – provides ample room to install standard and wide-access dispenser sumps from the top of the island.
- ◆ **Unique Sump Mounting System** – ensures the dispenser sump is anchored to the Island Form and adjustable to accommodate various width sumps.
- ◆ **Convenient Shipping and Storage** – revolutionary threaded-stud bracing system allows forms to stack together and enables boxing of the island assembly.
- ◆ **Easy Installation** – cross braces bolt onto threaded studs. Field welding is not required.
- ◆ **Attractive Appearance** – link plates impart a crisp, clean exterior joint between sections for a smooth, finished presentation.
- ◆ **Material** – Standard models are 12-gauge steel powder-coated gray and stainless-steel models are 304 stainless.

OPW Island Forms

Designed to protect gasoline dispensers, electric vehicle (EV) chargers, electronic equipment, kiosks, bank teller and ATM equipment, as well as to restrict or route material-handling equipment in warehouses. OPW Island Forms and Protective Curbing streamline traffic flows in toll booths, quick-serve restaurants and various other commercial traffic-management applications.

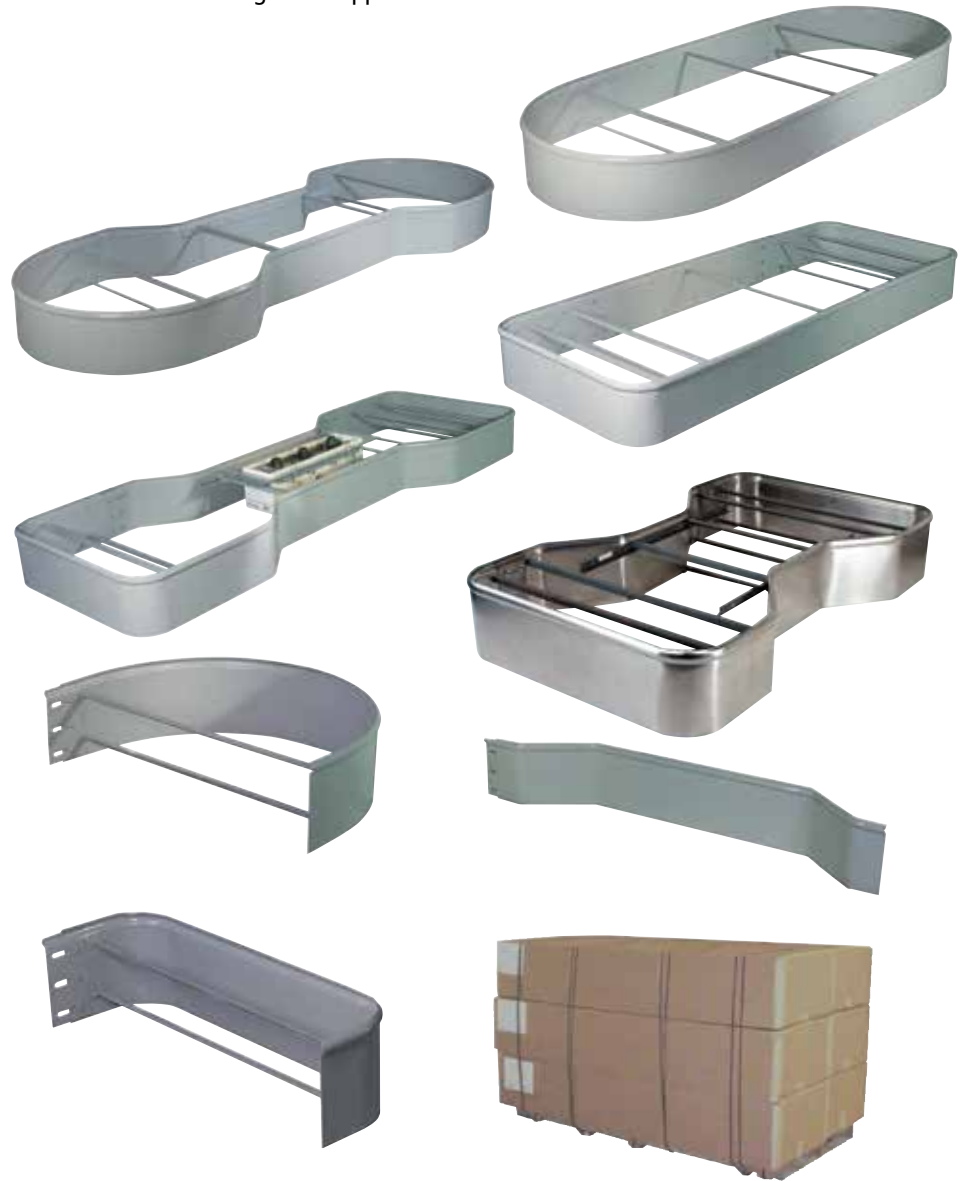

Pre-Assembled Island Forms

Model #	Comments	Width	Length	Radius Corner
6013-SFR6W3L5-ASSY	Steel Island Form, Assembled	3'	5'	6"
6013-SFR6W4L5-ASSY	Steel Island Form, Assembled	4'	5'	6"
6013SS-SFR6W3L5-ASSY	Stainless-Steel Island Form, Assembled	3'	5'	6"
6013SS-SFR6W4L5-ASSY	Stainless-Steel Island Form, Assembled	4'	5'	6"

Can pre-assemble islands max 4' wide, 5' long.

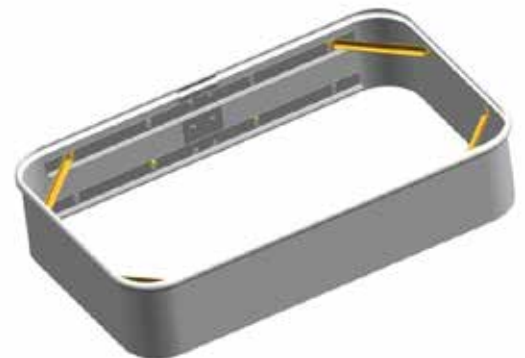

Listings and Certifications



2005 UL Standard for safety for non-metallic underground piping for flammable liquids, UL971.

Hourglass Island Form Specification/Ordering Guide

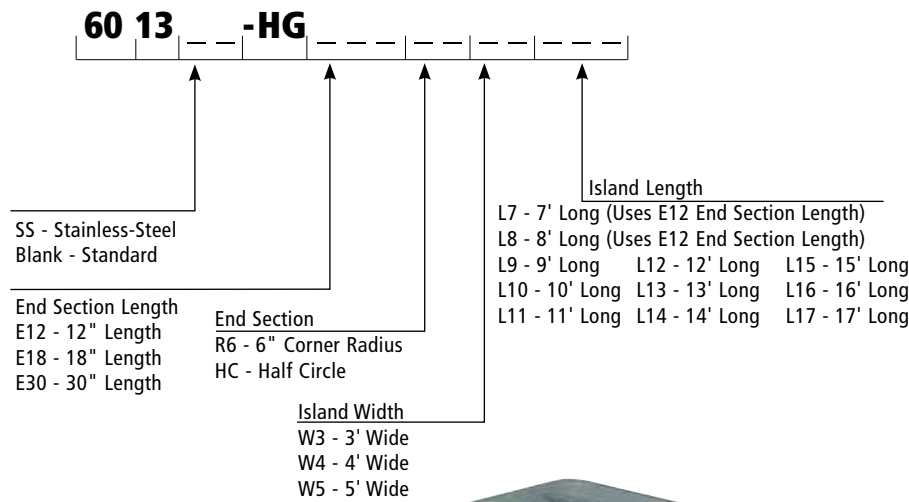

Specify Standard Island Form configurations designed by OPW for a wide variety of retail, commercial and industrial traffic-management applications.

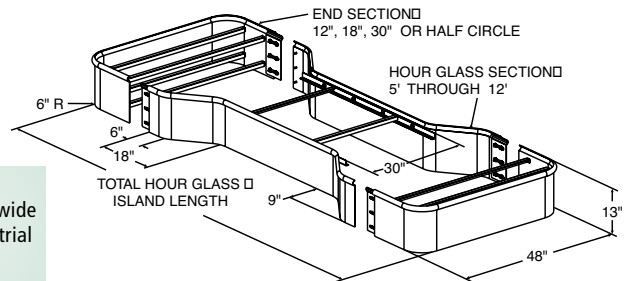

OPW Standard Island Forms

Specify Standard Island Form configurations designed by OPW for a wide variety of retail, commercial and industrial traffic-management applications. Available in hot-rolled 12-gauge primed gray steel and stainless-steel models are 304-grade stainless.

Hourglass Island Forms

Hourglass Island Forms are designed with side sections integrating a double-reverse 9" taper to provide easy access to multi-product gasoline dispensers while protecting expensive electronic equipment. Ends of these islands can be extended to wrap around canopy columns, hose bibs or trash receptacles by simply adding straight sections.

Standard (Straight) Island Form Specification/Ordering Guide

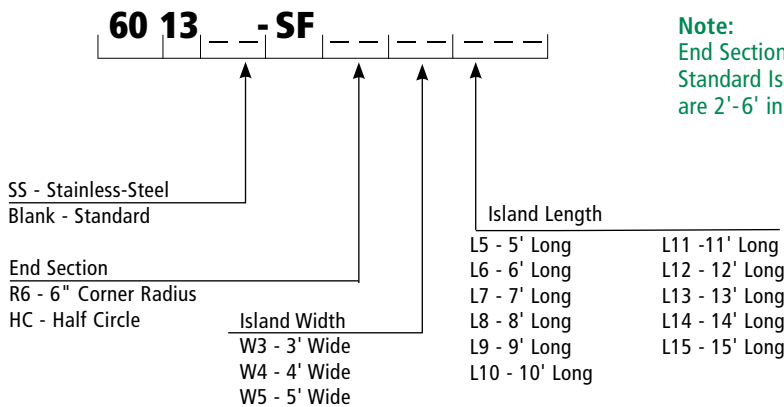

Note:
End Sections on Standard Island Forms are 2'-6" in length.

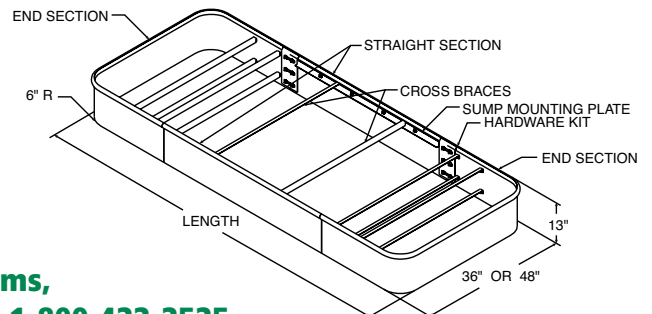

Standard (Straight) Island Forms

Straight Island Forms are designed with straight side sections to provide a convenient means of installing multiple dispensers on a single island. Straight Island Forms are also used to protect teller and ATM equipment at banks, restrict or route material-handling equipment in warehouses, streamline traffic flows in toll booths and quick-serve restaurants and various other commercial traffic-routing applications. Standard models are steel and stainless-steel models are 304 stainless.

For Custom Island Forms,
Contact OPW Customer Service at 1-800-422-2525

Build Your Own Island Form Or Curbing From Individual Sections

Build your own Island Forms and Protective Curbing to fit your particular application from standard sections. Standard models are steel and stainless-steel models are 304 stainless.

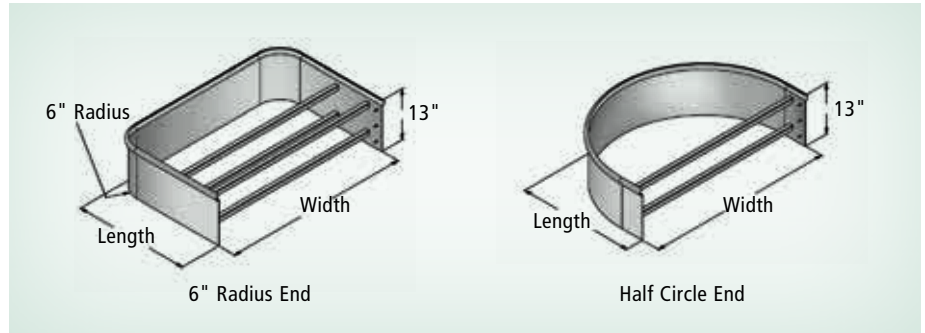

Standard Island Form End Sections

End Sections are available to build customized Island Forms from standard OPW Island Form components. Sections are available in Half Circle or 6 inch Radius configurations. Each End Section is pre-braced and includes all required hardware for assembly.

Ordering Specifications (Standard End Sections)

Model #	Radius (in.)	Width (ft)	Length	Weight
6013P-EHCW3L30	Half Circle	3	2' 6"	37 lbs.
6013P-EHCW4L30	Half Circle	4	2' 6"	40 lbs.
6013P-ER6W3L18	6	3	1' 6"	37 lbs.
6013P-ER6W3L30	6	3	2' 6"	45 lbs.
6013P-ER6W4L12	6	4	1'	35 lbs.
6013P-ER6W4L18	6	4	1' 6"	40 lbs.
6013P-ER6W4L30	6	4	2' 6"	52 lbs.

Hourglass Sections

Hourglass Sections are designed with double-reverse 9 inch tapers to provide easy access to multi-product gasoline dispensers. One-piece Hourglass Sections are available from 5' through 9'. Sump Support Bars are included with individual Hourglass Sections. HGL and HGR sections can be used in conjunction with Straight Sections when designing longer Hourglass Islands, or for use in Protective Curbing applications.

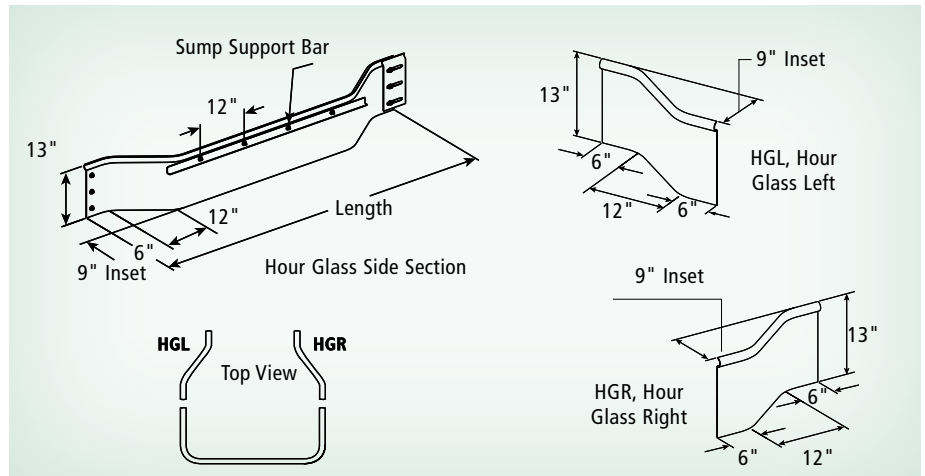

Ordering Specifications (Hourglass)

Model #	Length	Comments	Wgt (lbs.)
6013P-HGL	2'	Hourglass Left Side Section	13
6013P-HGR	2'	Hourglass Right Side Section	13
6013P-HG05	5'	Hourglass Side Section	35
6013P-HG06	6'	Hourglass Side Section	40
6013P-HG07	7'	Hourglass Side Section	45
6013P-HG08	8'	Hourglass Side Section	50

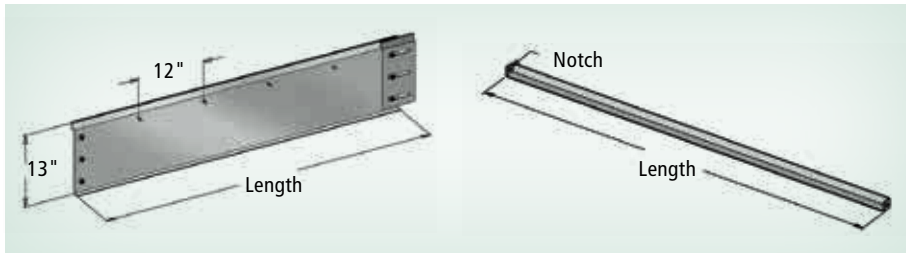

Straight Sections

Straight Sections are designed with a 1" bottom flange to add rigidity for accurate alignment of sections. Island Form End Sections are easily extended with various-length Straight Sections. Sump Support Bars are not included with individual Straight Sections. Straight Sections are key to the design of Protective Curbing.

Ordering Specifications

Model #	Length	Weight
6013P-S01	1'	6 lbs.
6013P-S015	1' 6"	9 lbs.
6013P-S02	2'	12 lbs.
6013P-S025	2' 6"	15 lbs.
6013P-S03	3'	18 lbs.
6013P-S035	3' 6"	21 lbs.
6013P-S04	4'	24 lbs.
6013P-S05	5'	30 lbs.
6013P-S06	6'	36 lbs.
6013P-S07	7'	42 lbs.

13" Mounting Plate
(Includes Hardware)

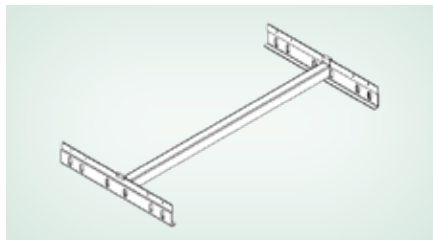

Sump Loop Mounting Bracket

Ordering Specifications

Model #	Mounting Kit Length
6000-SMK3	3 Foot
6000-SMK4	4 Foot
6000-SMK5	5 Foot

Cross Braces

Cross Braces are notched on both ends for use with Sump Support Bars. Holes punched in both ends slide over threaded studs to bolt the brace to the island. Bracing is recommended every 2 feet along the inside of Hour Glass and Straight Sections.

Ordering Specifications

Model #	Length (in.)	Weight
6000P-B24	24	1 lbs.
6000P-B30	30	2 lbs.
6000P-B36	36	2 lbs.
6000P-B42	42	2 lbs.
6000P-B48	48	3 lbs.
6000P-B60	60	3 lbs.

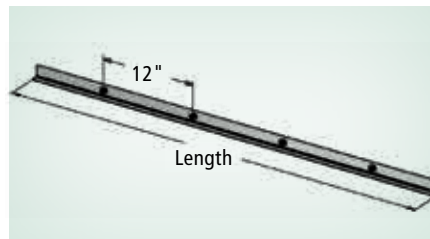

Sump Support Bars

Sump Support Bars are designed to allow OPW Island Forms to accept various-width sumps. The bars are positioned to locate the top of OPW Dispenser Sump Frames 1/2" above finished island grade to direct water drainage away from the sump. Sump Support Bars must be specified when designing Island Forms from individual Straight Sections.

Ordering Specifications

Model #	Length (in.)	Weight
6000P-SMP	54	3 lbs.

Build Your Own Island Form Or Curbing

Build your own Island Forms and Protective Curbing to fit your particular application from standard sections. Standard models are steel and stainless-steel models are 304 stainless.

Corner Sections

Corner Sections are designed for use in various Island Form widths, or for use in Protective Curbing applications.

Ordering Specifications

Model #	Length (in.)	Weight
6013P-R6C	12	10 lbs.

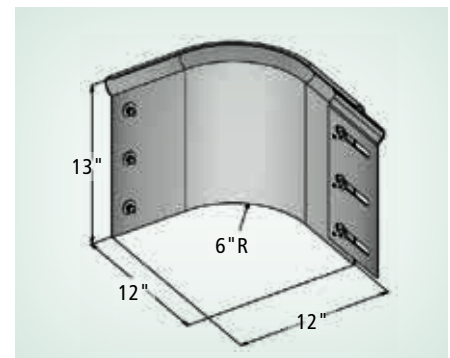

Curb Fascia Brackets

Curb Fascia Brackets replace cross braces and are designed to brace sections when utilized as protective curb fascia. The brackets are hole-punched for bolting to threaded studs, and allow for 1/2" diameter #4 reinforcement bars to secure the sections in place.

Ordering Specifications

Model #	Length (in.)	Weight
6000P-CFB	11	1 lbs.
6013P-Link Steel (12K Plate)		
6013SSP-Link Stainless-Steel Link		

Materials:

Hose: 322 Stainless-Steel
Wire Braid: 304 Stainless-Steel
Pipe Nipples: SCH. #80 Stainless-Steel
Swivel: Viton®/Buna Seals

Features:

- ◆ Maximum working pressure: 150 PSIG (10 bar)
- ◆ Service temperature range: -320°F to 1,500°F (-196°C to 816°C)
- ◆ Minimum burst pressure 750 PSIG (52 bar)
- ◆ Inherent hoop strength of convoluted hose allows full vacuum service

ULC/ORD-C536-1998
 (underground and aboveground installations)

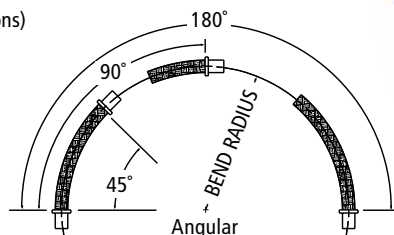
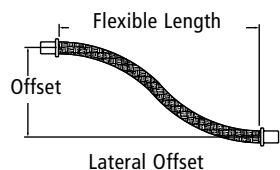

OPW Stainless-Steel Flexible Connectors

Stainless-Steel Flexible Connectors provide flexibility in the installation and operation of fuel-piping systems. Flexible Connectors can be used as a convenient means of connecting piping to pumps and dispensers and throughout the piping systems where connections and changes of direction are necessary. Flexible Connectors dampen the effect of ground and/or piping movement. All stainless-steel construction ensures long service life and corrosion protection. Flexible Connectors are rated for 150 psig (10 bar) working pressure, as well as for full vacuum service. Compatible with diesel, gasoline, methanol, ethanol and MTBE. Available as Male by Male and Male Swivel by Male, Male 90° and Easy Clamp Connectors.

Ordering Specifications and Dimensions

Model #	NPT Thread Size		Length		Hose O.D.		Max. Angular Bending (Degree)		Max. Lateral Offset				Min. Bend Radius			
	in.	mm	in.	mm	in.	mm	Static Position	Intermittent Flexing	Static Installation	Intermittent Flexing	Static Installation	Intermittent Flexing	Static Installation	Intermittent Flexing		
FC075-MM12	.75	19.1	12	304.8	1.0	25.4	100°	55°	2.0	50.8	1.2	30.5	4.5	114.3	8	203.2
FC10-MM12	1	25.4	12	304.8	1.3	33.0	70°	45°	1.4	35.6	0.9	22.9	5.5	139.7	9	228.6
FC10-MM18	1	25.4	18	457.2	1.3	33.0	135°	85°	4.5	114.3	2.1	53.3	5.5	139.7	9	228.6
FC10-MM24	1	25.4	24	609.6	1.3	33.0	180°	125°	8.6	218.4	2.1	53.3	5.5	139.7	9	228.6
FC15-MM12	1.5	38.1	12	304.8	2.25	57.2	90°	35°	1.5	38.1	.75	19.1	4	101.6	11	279.4
FC15-MM14	1.5	38.1	14	355.6	2.25	57.2	90°	35°	1.5	38.1	.75	19.1	4	101.6	11	279.4
FC15-MM18	1.5	38.1	18	457.2	2.25	57.2	150°	55°	4.0	101.6	1.5	38.1	4	101.6	11	279.4
FC15-MM24	1.5	38.1	24	609.6	2.25	57.2	180°	85°	8.0	203.2	2.75	69.9	4	101.6	11	279.4
FC15-MM30	1.5	38.1	30	762.0	2.25	57.2	180°	115°	12.0	304.8	2.75	69.9	4	101.6	11	279.4
FC20-MM12	2	50.8	12	304.8	2.72	69.1	75°	30°	1.5	38.1	0.60	15.2	5	127.0	12	304.8
FC20-MM14	2	50.8	14	355.6	2.72	69.1	75°	30°	1.5	38.1	0.60	15.2	5	127.0	12	304.8
FC20-MM18	2	50.8	18	457.2	2.72	69.1	120°	50°	3.0	76.2	1.5	38.1	5	127.0	12	304.8
FC20-MM24	2	50.8	24	609.6	2.72	69.1	180°	75°	7.0	177.8	3.0	76.2	5	127.0	12	304.8
FC20-MM36	2	50.8	36	914.4	2.72	69.1	180°	105°	12.0	304.8	3.0	76.2	5	127.0	12	304.8
FC30-MM18	3	76.2	18	457.2	3.97	100.8	70°	35°	2.0	50.8	1.0	25.4	8	203.2	16	406.4
FC30-MM24	3	76.2	24	609.6	3.97	100.8	110°	55°	4.8	121.9	2.5	63.5	8	203.2	16	406.4

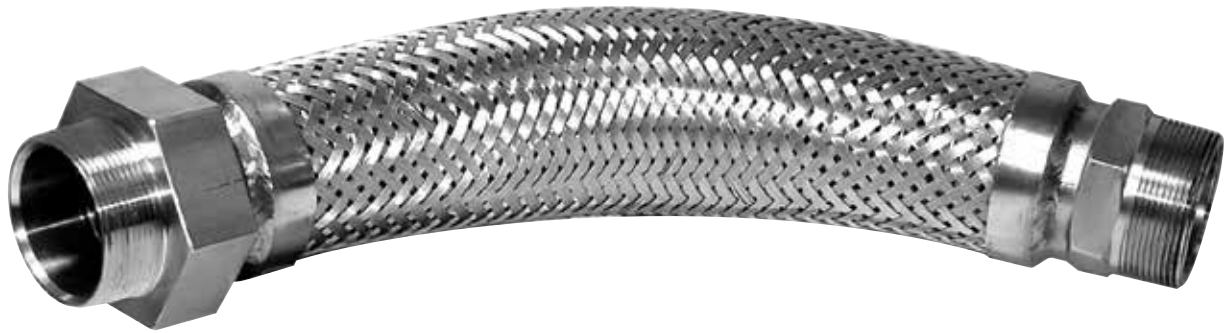

Integral Swivel Flexible Connector

Ordering Specifications and Dimensions

Model #	MALE SWIVEL x MALE		NPT Thread Size		Length		Hose O.D.		Max. Angular Bending (Degree)		Max. Lateral Offset				Min. Bend Radius			
									Static Position	Intermittent Flexing	Static Installation		Intermittent Flexing		Static Installation		Intermittent Flexing	
	in.	mm	in.	mm	in.	mm	in.	mm			in.	mm	in.	mm	in.	mm	in.	mm
FC15-SWM12	1.5	38.1	12	304.8	2.25	57.2	90°	35°	1.5	38.1	0.75	19.1	4	101.6	11	279.4		
FC15-SWM14	1.5	38.1	14	355.6	2.25	57.2	90°	35°	1.5	38.1	0.75	19.1	4	101.6	11	279.4		
FC15-SWM18	1.5	38.1	18	457.2	2.25	57.2	150°	55°	4.0	101.6	1.50	38.1	4	101.6	11	279.4		
FC15-SWM24	1.5	38.1	24	609.6	2.25	57.2	180°	85°	8.0	203.2	2.75	69.9	4	101.6	11	279.4		
FC20-SWM12	2	50.8	12	304.8	2.72	69.1	75°	30°	1.5	38.1	0.60	15.2	5	127.0	12	304.8		
FC20-SWM14	2	50.8	14	355.6	2.72	69.1	75°	30°	1.5	38.1	0.60	15.2	5	127.0	12	304.8		
FC20-SWM18	2	50.8	18	457.2	2.72	69.1	120°	50°	3.0	76.2	1.50	38.1	5	127.0	12	304.8		
FC20-SWM24	2	50.8	24	609.6	2.72	69.1	180°	75°	7.0	177.8	3.0	76.2	5	127.0	12	304.8		

Suction-System Accessories

OPW 70 Vertical Check Valves (with Shear Groove)

Materials

Body: Cast iron with black Duragard® E-coating
Disc: M-19 Viton



OPW Vertical Check Valves

OPW Vertical Check Valves are installed on suction-system fuel lines directly below the inlet to the pump in the dispenser island to maintain prime. The 70 Series Valves feature a built-in shear groove, which helps minimize piping damage if the dispenser is pulled over or dislodged by collision. The single-poppet provides redundant protection from losing prime and are also available without shear grooves. OPW Vertical Check Valves are recommended for use on suction-lines where the pressure does not exceed 34 feet of head (approximately 15 psi [1 bar]). 70 Series valves need 1/2" of mercury to activate the poppet.

Features

- ◆ **Low Pressure Drop**
- ◆ **M-19 Viton® Seals** – on main poppet for compatibility with methanol-blended fuels and reliable sealing
- ◆ **Protective Shear Groove** – designed to reduce the possibility of damage to buried piping in the event the dispenser is knocked over
- ◆ **Thermal Relief Valve** – to reduce pressure build-up in suction pumps. Opens between 25 & 35 PSI (1.7 & 2.4 bar)
- ◆ **Compatible with 85% Ethanol (E85) or Methanol (M85)**

Additional Features (70S Model)

- ◆ **Stabilizer Mounting Bosses** – three bosses in the lower portion of the valve body allow for rigid mounting to stabilizer bars. Use FlexWorks mounting plate with appropriate stabilizer bar kit
- ◆ **Built-In Air-Test Port** – allows air testing of the entire pumping system without breaking the line. Also allows line to be drained from the valve to the tank (assuming there are no other check or foot valves below the 70S)

Ordering Specifications

Model #	in.	mm	lbs.	kg
70-0070	1 1/2" NPT	38 mm	1.80	.8
70S-0075	1 1/2" NPT	38 mm	2.9	1.3

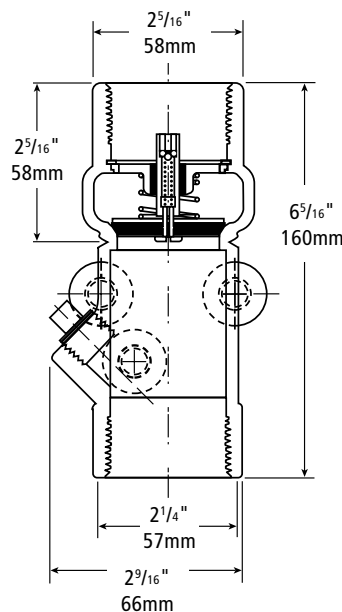
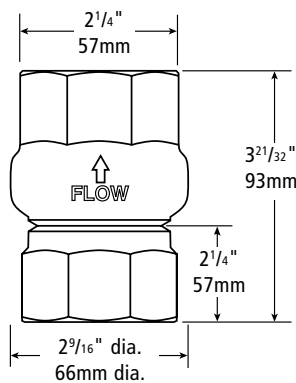

70 and 70S Vertical Check Valve Instruction Sheet
 Order Number: **H11055PA**

Warning: The valve body must be rigidly anchored to a structural member within the island to ensure breakage at the shear groove in the event of severe impact. The shear groove must be at the same level or a maximum of 1/2" above or below the top of the pedestal island. Failure to provide rigid mounting or install the shear groove at the proper level may result in a failure of the valve to close or shear, resulting in an excessive loss of product and a hazardous condition.

Underground Storage Tank Equipment



Phase I CARB Certified Enhanced Vapor Recovery (EVR) Product Overview	74 - 75
Phase I CARB Certified Enhanced Vapor Recovery (EVR) Torque Specs	76
Spill-Containment Manholes	77 - 92
Multiport Spill-Containment	93 - 100
Spill Container Product Identification Tags	101
Fill-Pipe Connection Equipment	102 - 113
Overflow-Prevention Equipment	114 - 124
Tank-Venting Equipment	125 - 128
Manholes & Monitoring Well Equipment	129 - 139

Listings and Certifications

CARB
California Air Resources Board



MOPETP
MISSOURI

MEXICO
FLORIDA
WISCONSIN
kiwa

Phase I CARB-Certified Enhanced Vapor Recovery (EVR) Product Overview

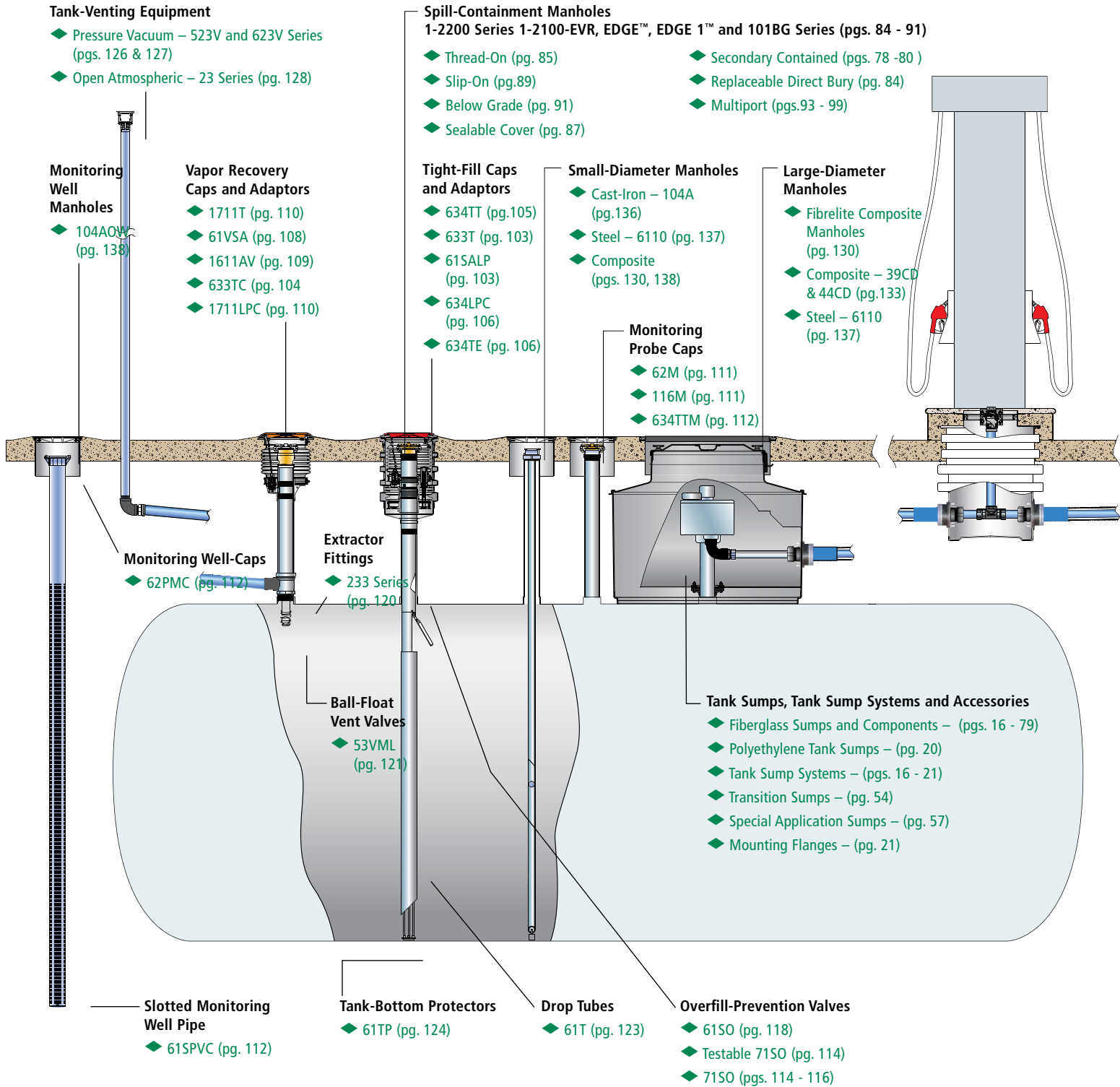

Listings and Certifications



MOPETP MISSOURI

MEXICO FLORIDA WISCONSIN kiwa

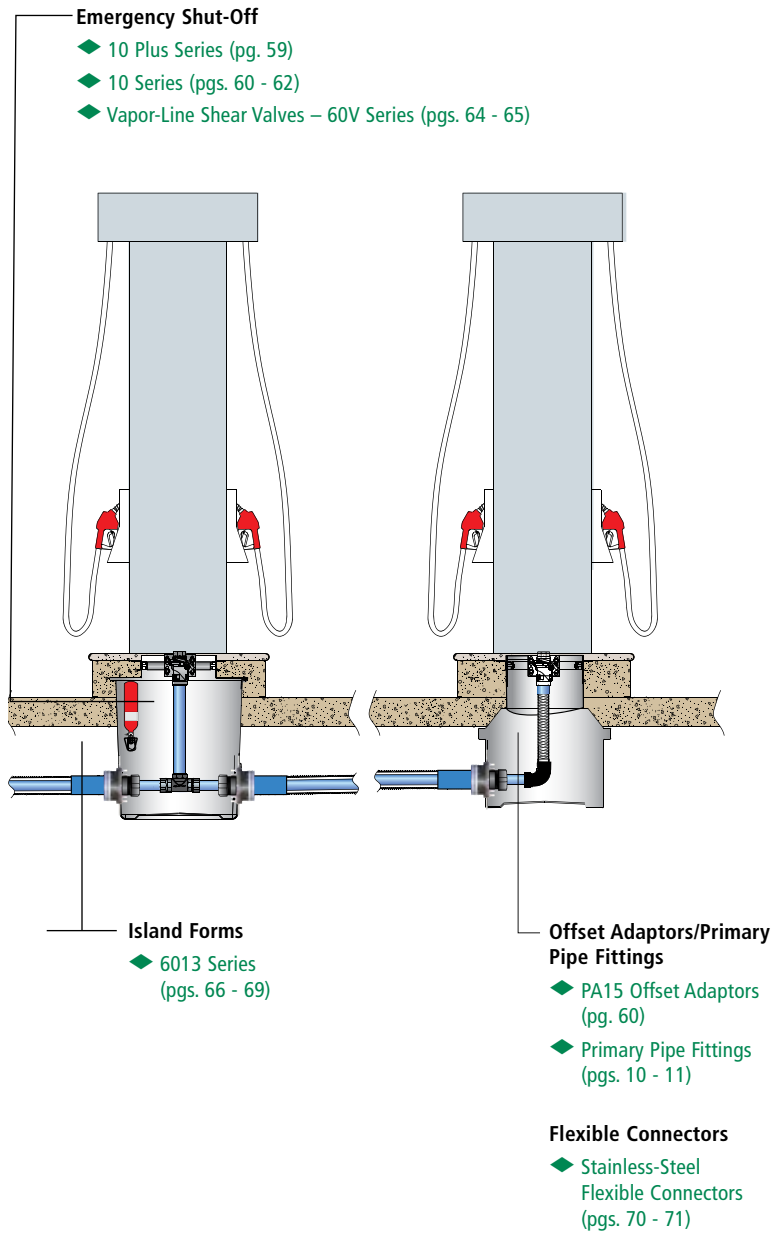

OPW Underground and Aboveground Storage Tank Fuel-Transfer and Containment Systems

OPW offers a wide selection of underground storage tank equipment. This equipment is designed to help protect the environment by providing fuel operations with spill-containment manholes, manholes and monitoring equipment, fill-pipe connection equipment, overfill-prevention equipment and tank-venting equipment.

OPW offers a wide variety of different spill-containment products, including innovative double-wall spill-containment and Phase 1 Enhanced Vapor Recovery (EVR) products, designed to prevent spilled product from entering the soil near the fill and vapor-return riser connections on USTs during normal tank-filling operation, or in the event of tank overfill. OPW spill-containers are designed to catch spillage to help prevent soil contamination and groundwater pollution.

OPW manholes provide access from grade-level to underground equipment including tank sumps, tank riser pipes, monitoring equipment, submersible pumps, valves and piping connections. OPW also offers a wide selection of tight-fill adaptors and caps, Stage I adaptors and caps and monitoring probe and well caps.

OPW overfill-prevention valves are designed to help prevent the overfill of USTs during product drops. OPW offers a wide selection, including 6150 and vaportight and testable 7150 positive shut-off valves, and ball-float vent valves.

NOTE: See OPW's Website at www.opwglobal.com for product instruction sheets, troubleshooting guides, how-to-use guides and to view the Do's & Don'ts at the Gas Pump video.

OPW Phase 1 Enhanced Vapor Recovery (EVR)/ Torque Specifications

In March 2000, The California Air Resources Board adopted new, more stringent vapor recovery requirements for gasoline-dispensing facilities. The new program, titled "Enhanced Vapor Recovery" (EVR), was developed to promote enhanced vapor recovery system reliability and to seek further reductions to meet both California and Federal Air Quality Requirements. Phase I EVR is now enforced in California.

For the purpose of reducing fugitive vapor emissions at gasoline-dispensing facilities, the California Air Resources Board has formally adopted new compliance requirements and certification procedures for vapor recovery equipment. These new requirements, know as Enhanced Vapor Recovery (EVR), define the most stringent and comprehensive performance and reliability requirements for Phase I Vapor Recovery Systems. Some important new requirements for a certified EVR Phase I system include:

- ◆ **EVR System Certification Test Protocol** – all components must now be installed and tested as a complete integral Phase I system
- ◆ **EVR System Efficiency** – must now exceed 98% versus 95% previously allowed
- ◆ **EVR System Performance** – allowable leak rates for components such as spill-container drain valves, overfill valves, and pressure vacuum vents have been cut by 50%
- ◆ **EVR System Reliability** – operating test period for a complete system increased from 90 days to 180 days

EVR Phase I Components Installation Torque Specifications (Oct 26, 2004)

On September 17, 2003, OPW received a second EVR certification for the Phase I Enhanced Vapor Recovery System. The new approval provides the option of using the ball-float with a straight drop tube or the positive shut-off overfill-prevention valve. OPW can offer the flexibility for installing an appropriately certified EVR system to meet the regulations in any jurisdiction for virtually any Phase I UST application. To review the EVR requirements visit: www.arb.ca.gov/vapor/vapor.htm

Component	Torque Specification Foot Pounds (Inch Pounds)
All 4" NPT pipe. See note 1	125 to 250 ft.lb.
FSA-400, FSA-400-S. See note 1	125 to 250 ft.lb.
Spill-containment bucket. See note 1	125 to 250 ft.lb.
Spill bucket cover perimeter bolts/nuts	20 to 25 ft.lb.
Drain valve retaining bolts/nuts	11 to 13 ft.lb.
61SO Inlet adaptor	11 to 13 ft.lb.
61JSK-4400	3 to 4 ft.lb. (36 to 52 in.lb.)
61JSK-4410	3 to 5 ft.lb. (42 to 60 in.lb.)
61JSK-44CB	3 to 5 ft.lb. (42 to 60 in.lb.)
61VSA Swivel Vapor Adaptor	90 to 110 ft.lb.
61SALP Low-Profile Swivel Fill Adaptor	90 to 110 ft.lb.
623V Pressure Vacuum Vent base	30 to 35 ft.lb.
233V Extractor Fitting. See note 1	125 to 250 ft.lb.
3" NPT	125 to 300 ft.lb.
2" NPT	100 to 150 ft.lb.
53VML Ball-Float Vent Valve and extractor cage - 3 3/4" threads	75 to 150 ft.lb.

Note 1: All 4" NPT threads are to be torqued progressively lower from the tank up.

Listings and Certifications



NOTE: See OPW's Website at www.opwglobal.com for product instruction sheets, troubleshooting guides, how-to-use guides and to view the Do's & Don'ts at the Gas Pump video.

OPW Multiports and Spill-Containment Manholes

OPW Spill-Containment Manholes are designed to prevent spilled product from entering the soil near the fill and vapor-return riser connections on underground storage tanks during normal tank-filling operation, or in the event of tank overfill. The spill-containers catch spillage to help prevent soil contamination and groundwater pollution.

Single-Wall Spill-Containment Manholes

The new OPW 1-2200 Series Single-Wall Spill-Containers are advanced, rugged, easier to install and service, upgrades to a double-wall and are more reliable than current single-wall spill-containers available today. Never break concrete again with our new EPA Compliant UST Solution for today, tomorrow and the future.

Double-Wall Spill-Containment Manholes

The new OPW EDGE™ 3100 Series Double-Wall Spill-Container is leading-edge spill-containment technology. Designed to help prevent spilled product from entering the backfill in the event the primary spill-container is damaged, the new OPW EDGE™ is dimensionally identical to single-wall spill buckets (from riser to grade), making single-to-double-wall upgrades quick, easy and affordable. No need to break concrete or replace riser pipes. Florida and North Carolina compliant.

Thread-On Spill-Containment Manholes

OPW Thread-On Spill-Containment Manholes are generally used on new tank or riser pipe installations. The spill bucket is threaded directly onto 4" NPT fill and vapor-return riser pipes. An integral drain valve allows contained product to be drained into the tank. OPW Thread-On Spill-Containers are available in 5-, 10- and 15-gallon capacities. Thread-On Double-Wall spill-containers are also available in 5-gallon capacities.

Sealable Cover Spill-Containment Manholes

OPW Sealable Cover Spill-Containment Manholes are designed to eliminate problems associated with water entering grade-level spill-containers, and are ideal for areas with poor drainage, areas subject to tropical rain and standing water, and cold regions where melting snow and road salt can enter standard spill-containers. An expandable cover seal is latched down, sealing against the I.D. of the mounting ring and preventing ingress of surface water. Sealable spill-containers are available in thread-on and slip-on configurations in 5 and 15-gallon capacities.

Slip-On Spill-Containment Manholes

OPW Slip-On Spill-Containment Manholes are used on new or existing UST riser pipes. The spill bucket slides onto 3" or 4" fill and vapor-return riser pipes and is then secured in place. Slip-on spill-containers provide a fast, economical way to replace uncontained manholes or fill boxes. An optional suction hand pump allows contained product to be evacuated into the tank. OPW Slip-On Spill-Containers are available in 5- and 15-gallon capacities.

Below-Grade Spill-Containment Manholes

OPW Below-Grade Spill-Containment Manholes are used in new tank or riser pipe installations. The watertight spill-containment chamber is installed completely below grade-level. A grade-level manhole cover lies flush with the driveway grade to reduce a tripping hazard and the potential for damage from snow-plows and traffic. Surface water drains into the backfill between the manhole skirt and the exterior of the containment bucket. Below-grade spill-containers are available in thread-on and slip-on configurations in 5- and 15-gallon capacities.

Fibrelite Multiport Spill-Containment Manholes

OPW Fibrelite Multiport Spill-Containment Manholes provide spill-containment for underground storage tank (UST) fill pipes and vapor recovery risers.

Multiports are installed over the top of tank sumps to preserve future access to the tank top and to facilitate containment of tank-bung fittings.

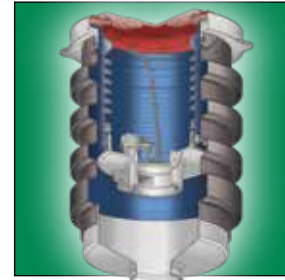

OPW EDGE™ Double-Wall Spill-Containers

Designed in collaboration with contractors and end-users, the OPW EDGE™ Double-Wall Spill-Container installs in the same space as single-wall buckets. The EDGE™ delivers best-in-class features that significantly improve reliability, installation, testing and ease of serviceability. The EDGE™ exceeds the performance levels of all other double-wall spill-containers.

- ◆ Fully Testable
- ◆ Unbeatable installation ease
- ◆ Uses existing riser pipe
- ◆ Unparalleled serviceability
- ◆ Superior quality
- ◆ Significantly reduces installation time and labor costs



Sealable Cover Option Available

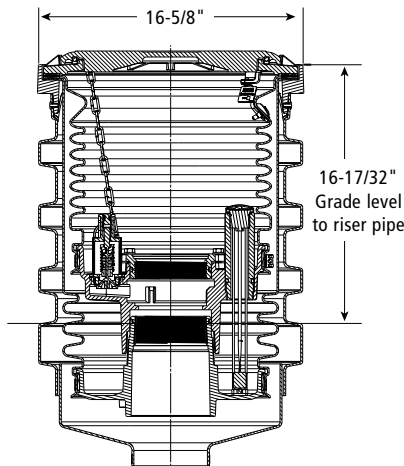

Weight: 120 lbs. (54.5 kg.)

Materials

- Cover:** Cast iron
- Mounting Ring:** Duragard®-coated ductile iron
- Bellows:** Polyethylene
- Base:** Cast iron E-coating
- Clamps:** Stainless-steel
- Seals:** Buna-N



Features

- ◆ **Top-Mounted Vacuum Test Port**
 - For quick and easy access
- ◆ **Superior Visual Gauge**
 - No messy dipsticks to contend with
 - Significantly simplifies and reduces testing time
- ◆ **Ease of Access to the Electronic Sensor for Testing**
 - Easy access for testing
 - Located to eliminate damage potential during product drops
- ◆ **Roto-Molded Primary & Secondary Buckets**
 - Thicker walls for greater durability and reliability
- ◆ **Ribbed Polyethylene Skirt Design**
 - Roto-molded for long-life durability
 - Provides rigidity for added durability
 - Provides handles on all sides for ease of installation
- ◆ **Patent-Pending Socket Design**
 - Enables the EDGE™ to install into the space of a single-wall spill-container
 - Helps to align bucket on riser
- ◆ **Patent-Pending Ledge Design**
 - Provides machined sealing face for drop tube
 - Improves overall drop tube sealing integrity
 - Eliminates face seal adaptors or de-burring of the riser pipe to obtain a flat surface for the drop tube
- ◆ **Patent-Pending Removable Adaptor**
 - Allows for quick and easy access to drop tube
 - Eliminates the need for cumbersome chain wrenches
- ◆ **Bellow Seals**
 - Improves overall sealing integrity
 - Eliminates mess and curing time found in sealants
 - Reduces service time and costs
- ◆ **SC Test**
 - Vacuum Testing Lid for Edge, 2200, 21000 and Multiports

Listings and Certifications



Ordering Specifications

The Edge™ Double-Wall Models - Fill Ports with Drain-Valves

Part #	Gal.	liter	Cover	Gauge/Sensor	lbs.	kg.
1C-3112D	5	19	Cast-Iron	Float Gauge	127	58
1C-3122D	5	19	Cast-Iron	Port Only (sensor not included)	127	58
1C-3132D	5	19	Cast-Iron	Electronic Sensor; 2 Stage, Normally Closed	127	58
1C-31512D	15	57	Cast-Iron	Float Gauge	185	84
1C-31532D	15	57	Cast-Iron	Electronic Sensor; 2 Stage, Normally Closed	185	84
1SC-3112D	5	19	Sealable	Float Gauge	127	58
1SC-3122D	5	19	Sealable	Port Only (sensor not included)	127	58
1SC-3132D	5	19	Sealable	Electronic Sensor; 2 Stage, Normally Closed	127	58
1SC-31512D	15	57	Sealable	Float Gauge	185	84
1SC-31532D	15	57	Sealable	Electronic Sensor; 2 Stage, Normally Closed	185	84

Installation Tools & Testing Equipment

1-3100-TOOL	Installation Tool for the EDGE™ DW Spill-Container
DW-VAC-TEST	Double-Wall Vacuum Tester
SC-VAC-TEST	Vacuum Testing Lid for OPW Spil Buckets

The Edge™ Double-Wall Models - Vapor Ports with Plug

Part #	Gal.	liter	Cover	Gauge	lbs.	kg.
1C-3112P	5	19	Cast-Iron	Float Gauge	127	58
1C-3122P	5	19	Cast-Iron	Port Only (sensor not included)	127	58
1C-3132P	5	19	Cast-Iron	Electronic Sensor; 2 Stage, Normally Closed	127	58
1C-31512P	15	57	Cast-Iron	Float Gauge	185	84
1C-31532P	15	57	Cast-Iron	Electronic Sensor; 2 Stage, Normally Closed	185	84
1SC-3112P	5	19	Sealable	Float Gauge	127	58
1SC-3122P	5	19	Sealable	Port Only (sensor not included)	127	58
1SC-3132P	5	19	Sealable	Electronic Sensor; 2 Stage, Normally Closed	127	58
1SC-31512P	15	57	Sealable	Float Gauge	185	84
1SC-31532P	15	57	Sealable	Electronic Sensor; 2 Stage, Normally Closed	185	84

Add the following to part number for colored powder-coated covers and rings.
Example 1C-3XXXD-W or 1SC-3XXXD-W

<input type="checkbox"/> White	-W	<input type="checkbox"/> Orange	-O	<input type="checkbox"/> Yellow	-Y
<input type="checkbox"/> Red	-R	<input type="checkbox"/> Blue	-B	<input type="checkbox"/> Bronze	-BZ

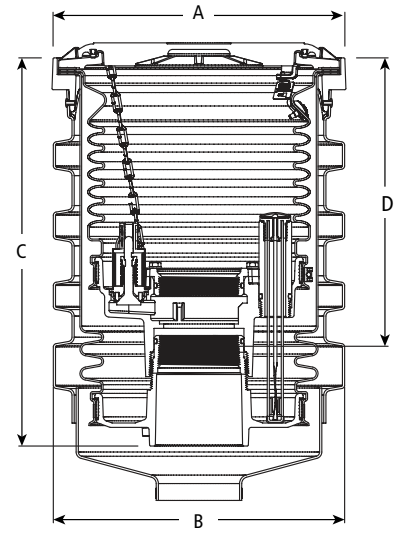

Dimensions 5-gallon EDGE™

	in.	cm
A	16 ⁵ / ₈	42
B	16 ¹⁹ / ₃₂	42
C	22 ¹ / ₈	56
D	16 ⁷ / ₁₆	42

Dimensions 15-gallon EDGE™

	in.	cm
A	24 ⁷ / ₈	63
B	24 ¹ / ₂	62
C	24 ¹ / ₂	62
D	18	46

Powder-Coated Sealable Cover Rings

Powder-coated rain-tight rings and covers provide a long-lasting, high-quality, vivid color meant to help prevent cross-contamination on the tank pad. The powder-coated finish is offered on ALL our single-wall and double-wall EDGE models.

Ordering Specifications

Product #	Description
SC-WHITE	Sealable cover replacement (5 Gallon Edge)
SC-ORANGE	Sealable cover replacement (5 Gallon Edge)
SC-RED	Sealable cover replacement (5 Gallon Edge)
SC-YELLOW	Sealable cover replacement (5 Gallon Edge)
203035	Edge SC Ring, Dursaslide / WHITE POWDERCOAT
217500	Edge SC Ring, Dursaslide / ORANGE POWDERCOAT
217501	Edge SC Ring, Dursaslide / RED POWDERCOAT
217502	Edge SC Ring, Dursaslide / YELLOW POWDERCOAT

Sealable Cover Edge

Product #	Description
1SC-3112D-R	RED Sealable Cover Edge
1SC-3112D-W	WHITE Sealable Cover Edge
1SC-3112D-Y	YELLOW Sealable Cover Edge
1SC-3112P-R	RED Sealable Cover Edge
1SC-3112P-W	WHITE Sealable Cover Edge
1SC-3112P-Y	YELLOW Sealable Cover Edge
1SC-3112P-O	ORANGE Sealable Cover Edge
1SC-3132D-R	RED Sealable Cover Edge
1SC-3132D-W	WHITE Sealable Cover Edge
1SC-3132D-Y	YELLOW Sealable Cover Edge
1SC-3132P-R	RED Sealable Cover Edge
1SC-3132P-W	WHITE Sealable Cover Edge
1SC-3132P-Y	YELLOW Sealable Cover Edge
1SC-3132P-O	ORANGE Sealable Cover Edge
1SC-3101P-O	ORANGE Sealable Cover Edge



UNDERGROUND PRODUCTS

Replacement Parts/Accessories

Part #	Description	Part #	Description	Part #	Description
1-21CC-XX (XX = Color)	5 Gallon Cast-Iron RT cover	211465	Visigauge Complete S/A	205987-KIT	15 Gallon Primary Bucket with Drain-Valve
1-21AC	5 Gallon Aluminum RT Cover	206017	Sensor Adaptor S/A (Primary)	206215-KIT	15 Gallon Primary Bucket with Plug
H12229M	5 Gallon Cover Seal for 1-21AC and 1-21CC	211064	Visigauge (only)	202137-KIT	5 Gallon Secondary Replacement Kit for Float Gauge
1-31RTR-X (x=Color)	5 Gallon Snow-Plow Ring	201972	O-Ring, Visigauge Adaptor	206010-KIT	5 Gallon Secondary Replacement Kit for Sensor Buckets
201689	5 Gallon Seal for Snow-Plow Ring	202013	O-Ring, Visigauge	206011-KIT	5 Gallon Secondary Replacement Kit for Electronic Sensor
203340	15 Gallon Rain Tight Rings	1DK-2100-EVR	Drain-Valve Sub Assembly	205988-KIT	15 Gallon Secondary Bucket Assembly
H12229M	15 Gallon RT Cover Seal	201739	Nipple Adaptor	203269	Replacement 2 Stage, Normally Closed Sensor and Sealed Base Plug; Used in 1C-xx32 series Edge
SC-XXXX (XXX = Color)	5 or 15 Gallon Sealable Covers Powder-Coated	C05446M	15 Gallon Main Cover Seal	210490	Replacement Tri State Sensor and Sealed Base Plug, Used in 1C xx42x series Edge
203035	5 Gallon Sealable Cover Replacement Snow-Plow Ring (White)	201686	S/A Secondary Gravel Guard	211079	Sensor Only Standard
217500	5 Gallon Sealable Cover Replacement Snow-Plow Ring (Orange)	202135-KIT	5 Gallon Primary Bucket with Drain-Valve	210488	Sensor Only
217501	5 Gallon Sealable Cover Replacement Snow-Plow Ring (Red)	H12267	Wood Block Leveling Kit	201692	O-Ring for 201739 Nipple Adaptor
217502	5 Gallon Sealable Cover Replacement Snow-Plow Ring (Yellow)	202136-KIT	5 Gallon Primary Bucket with Plug	Float Gauge & Sensor Adaptor not included with replacement buckets	
1DP-2100	Plug Kit	Add the following to part number for colored powder-coated covers and rings. Example 1C-3XXXD-W or 1SC-3XXXD-W			
SCR Series	15 Gallon Sealable Cover Replacement Snow-Plow Ring				

<input type="checkbox"/> White	-W	<input type="checkbox"/> Orange	-O	<input type="checkbox"/> Yellow	-Y
<input type="checkbox"/> Red	-R	<input type="checkbox"/> Blue	-B	<input type="checkbox"/> Bronze	-BZ

EDGE™ Replacement Cartridge Kit

Original Edge Model	Original Product Description	Primary-Containment Replacement Kit	Secondary-Containment Replacement Kit	Primary and Secondary Containment Replacement Kit/EDGE 1 Upgrade Kits
1C-3112D / 1SC-3112D	DW EDGE: Drain-Valve + Gauge	202135-KIT	202137-KIT	202135-KIT + 202137-KIT + 211465
1C-3112P / 1SC-3112P	DW EDGE: Plug and Gauge	202136-KIT	202137-KIT	202136-KIT + 202137-KIT + 211465
1C-3122D / 1SC-3122D	DW EDGE: Drain-Valve and Sensor Access Port	202135-KIT	206010-KIT	202135-KIT + 206010-KIT + 206017
1C-3122P / 1SC-3122P	DW EDGE: Plug and Sensor Access Port	202136-KIT	206010-KIT	202136-KIT + 206010-KIT + 206017
1C-3132D / 1SC-3132D	DW EDGE: Drain-Valve & 2 Stage Norm. Closed Sensor	202135-KIT	206011-KIT	202135-KIT + 206011-KIT + 206017
1C-3132P / 1SC-3132P	DW EDGE: Plug & 2 Stage Norm. Closed Sensor	202136-KIT	206011-KIT	202136-KIT + 206011-KIT + 206017
1C-3101D / 1SC-3101D	EDGE 1: Drain-Valve	203193-KIT		
1C-3101P / 1SC-3101P	EDGE 1: Plug	203194-KIT		
1C-31512D / 1SC-31512D	DW Edge: 15 Gallon Drain-Valve + Gauge	205987-KIT	205988-KIT	205987-KIT + 205988-KIT + 211465
1C-31512P / 1SC-31512P	DW Edge: 15 Gallon Plug + Gauge	206215-KIT	205988-KIT	206215-KIT + 205988-KIT + 211465
1C-3142D / 1SC-3142D	DW Edge: Drain and Tri-State Sensor	202135-KIT	210493-KIT	202135-KIT + 210493-KIT + 206017
1C-3142P / 1SC-3142P	DW Edge: Plug and Tri-State Sensor	202136-KIT	210493-KIT	202136-KIT + 210493-KIT + 206017

Replacement Parts/Accessories

Part #	Description
SC-Test	Testable Sealable cover for SC Edge or 1-2200 buckets

4" Threaded Nipples for Mating Spill Bucket to Adaptor

Part #	Description
TC-400	4" Torque Cap
H15144M	4" NPT Nipple, 4" Length
H12806M	4" NPT Nipple, 5" Length
VPN4X7	4" NPT Nipple, 7" Length
H15271M	4" NPT Nipple, 8" Length
H15268M	4" NPT Nipple, 10" Length
12807M	4" NPT Nipple, 12" Length

4" Riser Extenders

Part #	Description
206121	4" NPT Riser Pipe Extender, adds 2" to Height
206122	4" NPT Riser Pipe Extender, adds 3.25" to Height

206122 Adapter
(adds 3.25")



206121 Adapter
(adds 2")



SC Tester



Threaded Nipple

OPW EDGE 1™ Single-Wall Spill-Container

Introducing an advanced single-wall spill-container – the new EDGE 1™ by OPW. The new EDGE 1™ is rugged, easier to install and service, upgrades to a double-wall and is more reliable than current single-wall spill-containers available today. Leading-EDGE design features and superior materials of construction combine with expert spill-containment engineering excellence to deliver more benefits than any other single-wall spill-container, making the EDGE 1™ number one in:

- ◆ Installation and upgradeability ease
- ◆ Serviceability ease
- ◆ Durability and long-life reliability

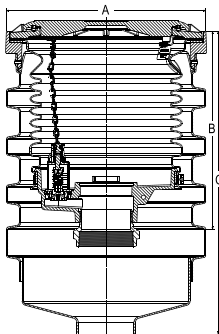

A = 16 5/8"
B = 16 15/32"
C = 25 1/4"

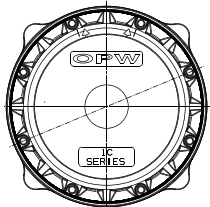

Replacement Parts/Accessories

Part #	Description
201689	Mounting Ring Seal
201530	Snow-Plow Ring
201692	O-Ring, Nipple Adaptor
1-21CC	Cover
203035	Sealable Cover Ring
H12229M	Cover Seal
SC-xxxx	(Xxxx=Color) Sealable Cover
1DK-2100-EVR	Drain-Valve Sub Assembly
203193-KIT	Replacement 5-Gallon with Drain-Valve
203194-KIT	Replacement 5-Gallon with Drain Plug
IP-2105	Hand Pump

Materials

- Cover:** Cast iron
- Mounting Ring:** Duragard®-coated ductile iron
- Bellows:** Polyethylene
- Base:** Cast iron E-coating
- Clamps:** Stainless-steel
- Seals:** Buna-N

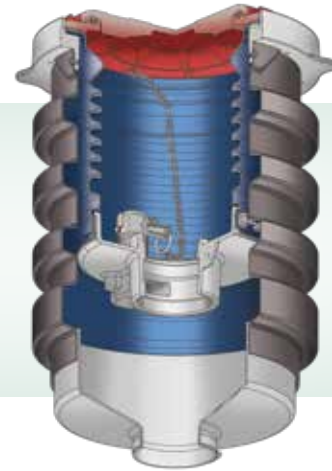

Features

- ◆ Upgradeable to a double-wall bucket without breaking concrete
- ◆ Quick, easy replacement of spill bucket and mounting ring without breaking concrete – significantly reduces labor time and cost
- ◆ High-quality materials of construction
 - Roto-molded technology - provides for thicker, more robust bellows
 - Heavy-duty ductile-iron mounting ring - provides superior long-term reliability and damage protection against traffic drive-over and snow-plows
 - The integral pull-to-open drain valve uses non-corrosive and stainless-steel materials, unlike our competitors, which have corrosive materials in their design (a drain plug version is also available)
- ◆ Thread-on bucket design - ensures leak-free integrity, especially in the event of ground movement
- ◆ Corrosion-resistant polyethylene skirt – increased rigidity and durability, superior reliability over corrosive metallic skirts
- ◆ Unique concrete anchoring ring – wide-lip and four (4) convenient anchoring ears provide for better anchoring and longevity

Ordering Specifications

Model #	Description	Weight	
		lbs.	kg
1C-3101D	The EDGE 1™ SW Spill-Container, 5 Gallon capacity, with Cast-Iron Cover and Drain-Valve	117	53
1C-3101P	The EDGE 1™ SW Spill-Container, 5 Gallon capacity, with Cast-Iron Cover and Drain Plug	117	53

NOTE: Any model can be purchased with a sealable cover option by using part number 1SC-XXXXD or 1SC-XXXXP.

NOTE: FSA-400-S must be installed with the EDGE 1™ to be upgraded to a double-wall spill bucket.

Add the following to part number for colored powder-coated covers and rings. Example 1C-3XXXD-W

<input type="checkbox"/> White	-W	<input type="checkbox"/> Orange	-O	<input type="checkbox"/> Yellow	-Y
<input type="checkbox"/> Red	-R	<input type="checkbox"/> Blue	-B	<input type="checkbox"/> Bronze	-BZ

Installation Tool

Model #	Description
61SA-TOOL	Wrench for Installation of the EDGE 1™ SW Spill-Container

Listings and Certifications



Materials

- Cover:** Black Epoxy-Coated Cast-Iron
- Mounting ring:** Duragard®-coated ductile iron
- Bellows:** Polyethylene
- Base:** Cast iron E-coating
- Seals:** Buna-N



OPW 1-2200 Series Replaceable Single-Wall Spill-Container

Introducing an affordable, all-accessible, all-replaceable and all-maintainable spill-container from OPW. Never break concrete again with our new EPA-Compliant UST Solution for today, tomorrow and the future.

Features

- ◆ Designed for proposed 2014 EPA Regulations and beyond
- ◆ Prepares you for future compliance
- ◆ Removable Bellows and Ring
- ◆ **Unique Flange Adaptor Feature-** Allows quick and easy removal of overfill valve without torquing base
- ◆ Built-In Face Seal Adaptor
- ◆ Innovative Snow-plow Ring-less, Liquid-Tight Cover with Integrated Lift Handle design
- ◆ Easy access for overfill-prevention valve testing and inspection
- ◆ Replace bucket without breaking concrete
- ◆ **ULC-Approved**

Ordering Specifications

Model #	Description
1C-2200D	Single-Wall, Field Replaceable Spill-Container with Drain-Valve
1C-2200P	Single-Wall, Field Replaceable Spill-Container with Drain Plug
1-3100-TOOL	Installation Tool, Used for Edge and 1-2200 Spill-Containers

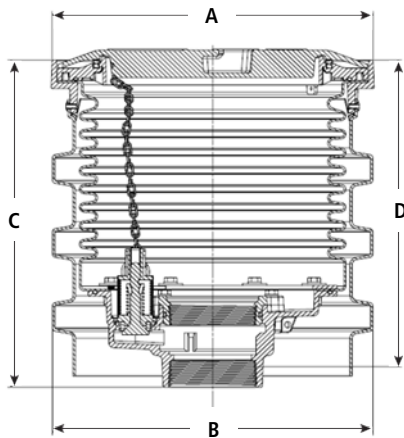

Dimensions

	in.	cm	lbs.	kg
A	16 ⁵ / ₈	42	77	34.9
B	16 ¹⁹ / ₃₂	42	77	34.9
C	17 ² / ₃	45	77	34.9
D	16 ⁷ / ₁₆	42	77	34.9



1-3100-TOOL Installation Tool

Listings and Certifications



Replace Bellows in 3 Easy Steps



Remove Upper Bolts and Ring

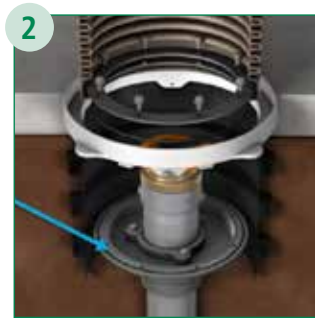

Remove Lower Bolts and Ring and Remove Bellows



Replace Bellows, Reinstall Upper and Lower Rings

No Need to Remove Base in Order to Replace Bellows

Liquid-Tight Cover

Special Cover and Ring Design
Seals Out Water and Debris

Eliminates Need for Snow-Plow Ring
Flush with Finish Grade

Proven "Bubble Seal"

Removable Compression Ring

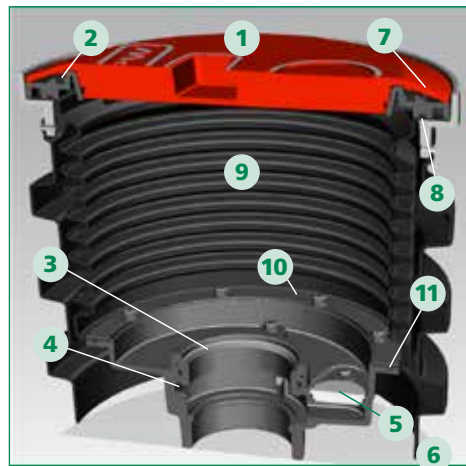
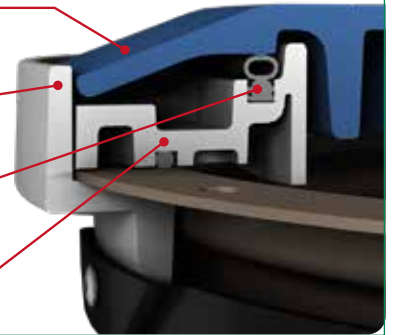

1-2200 Series Replacement Parts

Part/Kit Number	Description
1	207235 Cover
2	H12229M Cover Seal
3	201739 Flange Adaptor
4	201692 Flange Adaptor O-ring
5	1DK-2100-EVR Drain-Valve Sub Assembly
6	1DP-2100 Drain Plug Kit
7	208951 Upper Ring Replacement Kit (Includes; O-ring and Hardware)
8	207243 Upper Ring O-ring
9	208952 Bellows Replacement Kit (Includes; O-rings, Split Rings, and Hardware)
10	207212 Lower Split Ring, Each (2 Required per Spill-Container)
11	207211 Lower Bellows O-ring
	208197 Installation Instructions

**1-2100-PEVR Series
Vapor Recovery Spill-Container**

**1-2100-DEVR Series
Product-Fill Spill-Container**

**OPW 1-2100-EVR
Series Direct-Bury
Spill-Containment
For CARB/EVR**

The OPW Thread-On 1-2100-EVR Series Spill-Containers are certified for installation on OPW Phase I EVR Systems. All Fill-Port Spill-Containers feature an enhanced 1DK-2100-EVR vapor-tight drain valve (DEVR Models). The Vapor Return Spill-Containers (PEVR Models) feature a permanent plug in the drain port as per EVR requirements. The 1-2100-EVR Series Thread-On Spill-Containers are available in Composite or Cast-Iron bases with either 5- or 15-gallon buckets.

The FSA-400 Threaded Riser Face Seal Adaptor is installed on the fill pipe below the spill-container to provide a true sealing surface for the drop tube flange on the 61SO and 71SO overfill-prevention valve. The 61SO and 71SO series valves are installed in the base of the OPW EVR spill-container with the patent-pending 61JSK Jack Screw device. This configuration allows liquid in the spill-container to be drained directly into the drop tube thereby isolating the drain valve from the tank ullage, eliminating a notorious leak point in previous systems.

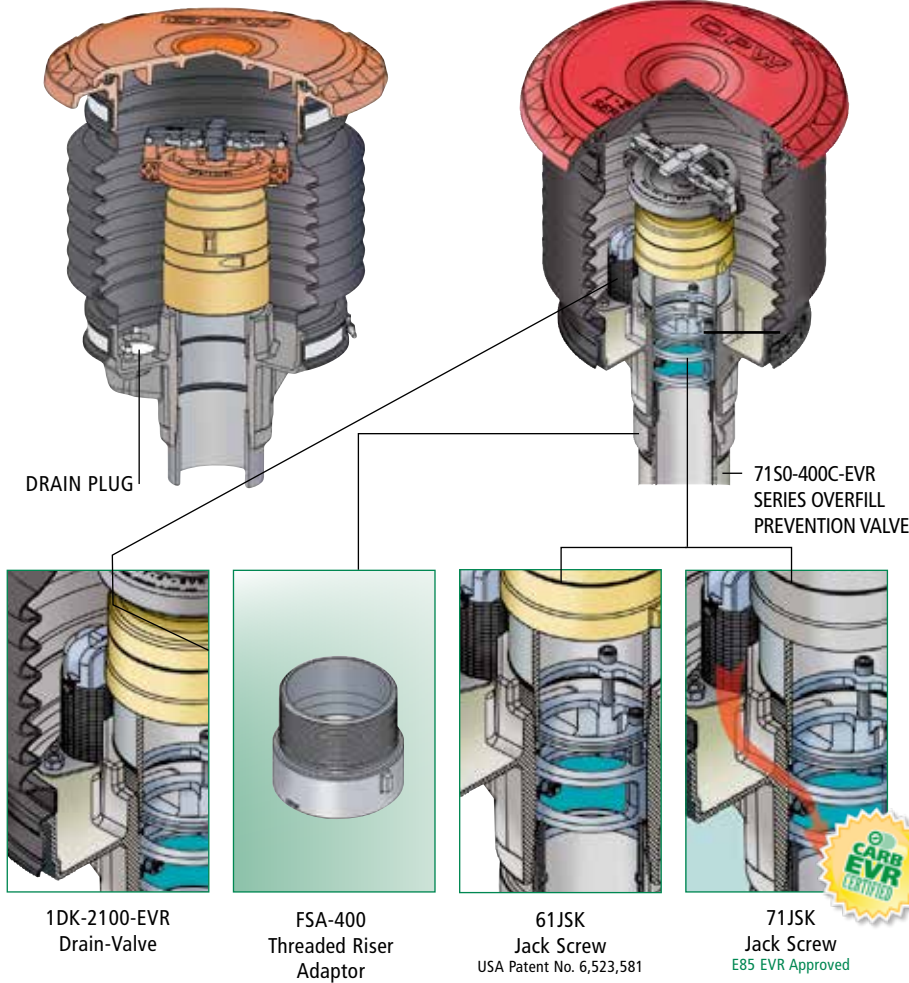

OPW Threaded Riser Adaptor (Face Seal Adaptor)

An OPW FSA-400 Threaded Riser Face Seal Adaptor provides a flat, true sealing surface on threaded pipes where a gasket seal exists per EVR requirements. The FSA-400 is installed on the fill pipe riser below the spill-container to provide a true sealing surface for the drop tube flange on the overfill-prevention valves. The FSA-400 is also required on tank-gauging risers and optional on vapor risers and rotatable adaptors.

**61JSK, 71JSK (Jack Screw Device)
Ordering Specifications**

Product #	Description
FSA-400	4" Face Seal Adaptor
FSA-400-S	4" Short Face Seal Adaptor for Cast-Iron Base Only
61JSK-4410	Jack Screw Kit for Composite Base Spill Bucket
61JSK-44CB	Jack Screw Kit for Cast-Iron Base Spill Bucket
71JSK-4RMT	Remote Fueling Jack Screw Kit E85 EVR Approved
71JSK-44MA	Jack Screw Kit for Cast-Iron Base Spill Buckets E85 EVR Approved

**OPW 1-2100 Series
Thread-On Spill-Containers**

OPW Spill-Containment Manholes are designed to prevent spilled product from entering the soil near the fill and vapor-return riser connections on underground storage tanks during normal tank filling operation, or in the event of tank overflow. The spill-containers catch spillage to help prevent soil contamination and groundwater pollution. OPW Thread-On Spill-Containment Manholes are generally used on new tank or riser pipe installations.

Materials

- Cover:** Cast aluminum or cast-iron
- Mounting Ring:** Cast iron E-coating
- Bellows:** Polyethylene
- Base:** Cast iron E-coating or Duratuff® II
- Clamps:** Stainless-steel
- Seals:** Nitrile



1-2115,
15-Gallon

Features

- ◆ **Easy Installation** – reduces job-site time and installation costs. OPW Thread-On Spill-Containers screw directly onto 4" NPT riser. No external connections to make; adjust the final grade height and support the unit with backfill
- ◆ **Integral Pull-to-Open Drain-Valve** – allows high-speed drainage of excess product into the tank. Designed with a convenient self-cleaning seal and removable screen for easier component cleaning
- ◆ **Capacity** – available in a true 5-gallon capacity as well as 15-gallon capacity
- ◆ **Rain-Shedding Cover** – available in either cast-aluminum or cast-iron, this unique design incorporates a seal in the underside of the cover. The seal seats between two dams on the mounting ring to prevent surface water from entering the spill-container.
- ◆ **Fuel Compatibility** – designed to accommodate the fuels of the future, including methanol, ethanol and fuels with MTBE additives
- ◆ **Product Identification Tags** – available for both the cover and bucket to positively identify the product contained in the UST with standard API symbols (See product I.D. tag specification page for more information: page 85.)
- ◆ **Heavy-Duty Mounting Ring** – the angled ramp design offers superior protection against snow-plow and traffic damage, and provides for secure concrete anchoring
- ◆ **Corrugated Bellows** – can be adjusted +/- 1" for desired grade-level
- ◆ **Duratuff® II or Cast-Iron Base** – composite Duratuff® II material is lightweight, durable, and conductive. A rugged, optional, cast-iron base is also available.
- ◆ **Highway 20 Rated (H20 /HS20)** – all OPW spill-containers and manholes exceed the requirements of the Highway 20 rating

**Listings and
Certifications**



DEVR Models – Fill Port with Drain-Valve

Duratuff® II Base with Drain-Valve Models

Model #	Gal.	Liter	Cover	lbs.	kg
1-2100-DEVR	5	19	Aluminum	40	18
1C-2100-DEVR	5	19	Cast-Iron	53	24
1-2115-DEVR	15	57	Aluminum	47	21
1C-2115-DEVR	15	57	Cast-Iron	60	27

Cast-Iron Base with Drain-Valve Models

Model #	Gal.	Liter	Cover	lbs.	kg
1-2100C-DEVR	5	19	Aluminum	40	18
1C-2100C-DEVR	5	19	Cast-Iron	53	24
1-2115C-DEVR	15	57	Aluminum	47	21
1C-2115C-DEVR	15	57	Cast-Iron	60	27

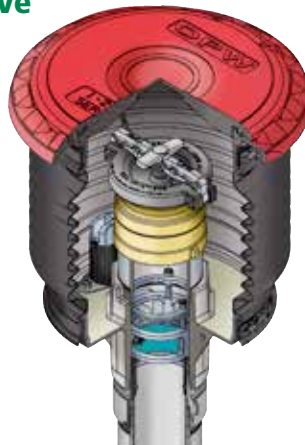

1-2100-DEVR Series
Product Fill Spill-Container

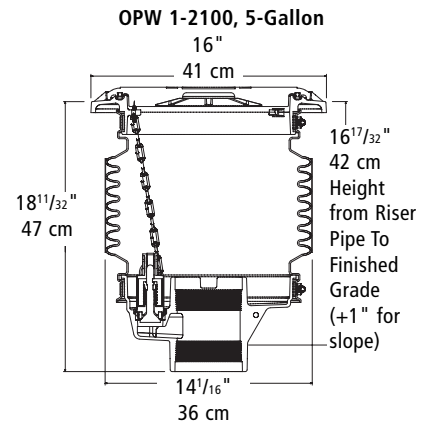

OPW 1-2115, 15-Gallon

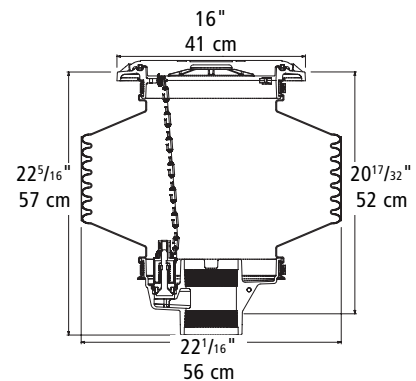

*Subtract 2" from height dimension for Cast-Iron Base Models.

NOTE: 20¹⁷/₃₂" dimension is height from riser pipe to finish grade (+1" for slope)

PEVR Models – Vapor Port with Plug

Duratuff® II Base with Plug Models

Model #	Gal.	Liter	Cover	lbs.	kg
1-2100-PEVR	5	19	Aluminum	40	18
1C-2100-PEVR	5	19	Cast-Iron	53	24

Cast-Iron Base with Plug Models

Model #	Gal.	Liter	Cover	lbs.	kg
1-2100C-PEVR	5	19	Aluminum	40	18
1C-2100C-PEVR	5	19	Cast-Iron	53	24

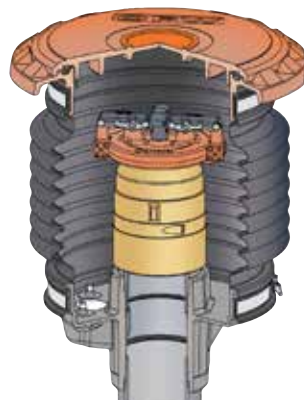

1-2100-PEVR Series
Vapor Recovery Spill-Container



4" Threaded Nipples for Mating Spill Bucket to Adaptor

Part #	Description
TC-400	4" Torque Cap
H15144M	4" NPT Nipple, 4" Length
H12806M	4" NPT Nipple, 5" Length
VPN4X7	4" NPT Nipple, 7" Length
H15271M	4" NPT Nipple, 8" Length
H15268M	4" NPT Nipple, 10" Length

Replacement Parts

Part #	Description
1DK-2100-EVR	Drain-Valve Kit
1-21AC	Aluminum Cover w/ Seal
1-21CC	Cast-Iron Cover w/ Seal
H12229M	Cover Seal
1PPK-2100	Hand Pump & Plug Kit for 1-2100
1DP-2100	Replacement Drain Plug Kit for 1-2100

Add the following to part number for color powder-coated 1-21CC covers

<input type="checkbox"/> White	-W	<input type="checkbox"/> Orange	-O	<input type="checkbox"/> Yellow	-Y
<input type="checkbox"/> Red	-R	<input type="checkbox"/> Blue	-B	<input type="checkbox"/> Bronze	-BZ

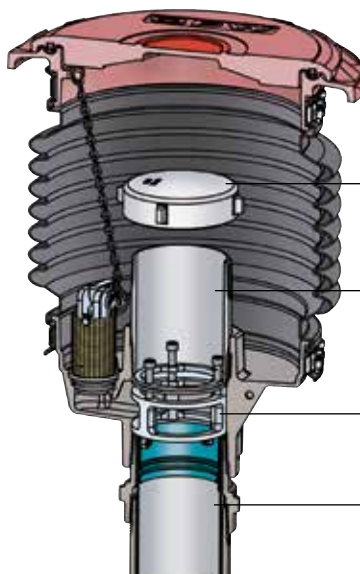

TC-400 Torque Cap

Provides an easy means of threading a 4" NPT nipple into a spill-container. The OPW TC-400 coupled with the OPW 61SA-TOOL can provide the necessary torque requirements for installing adaptor nipples for spill-containers. The TC-400 can easily be removed without disturbing the installed threaded nipple. The TC-400 also eliminates the need for a strap or chain wrench.

4" Threaded Pipe Nipple

OPW pipe nipples are CNC machined, providing a smooth sealing surface where a gasket seal exists. Available in various lengths to custom fit the necessary height requirements for Fill and Vapor Adaptors.

61JSK Jack Screw Device

See page 84 for detailed information.

FSA-400 Face Seal Adaptor

See page 84 for detailed information.

The following products are in compliance with California Water Resources Control Board (W.R.C.B.) for coating of buried metal components, such as stainless-steel clamps or entire Spill-Containment Bucket bottoms.

Part #	Description
SL-1100	Urethane Sealant (10.3 oz.)

W.R.C.B. approved CCR Title 23, Div. 16, Sec. 1631 & 2636

OPW 1SC-2100-EVR Series Sealable Cover Spill-Containers

OPW Spill-Containment Manholes are designed to prevent spilled product from entering the soil near the fill and vapor-return riser connections on underground storage tanks during normal tank-filling operations, or in the event of tank overflow. The spill-containers catch spillage to help prevent soil contamination and groundwater pollution. The OPW 1SC-2100-EVR Series Sealable Cover Spill-Containers are designed to eliminate the problems associated with water entering grade-level spill-containers. The operation of the cover is similar to that of a “plumbers plug.” When the lever is latched down, the plates are drawn together, expanding the seal against the machined mounting ring wall. The 1SC-2100-EVR spill-containers are ideal for areas with a high water table, areas subject to tropical rain and standing water, and cold regions where melting snow and road salt can enter standard spill-containers.

Materials

- Cover:** Cast aluminum
- Cover Seal:** Low-swell nitrile
- Lever:** Bronze
- Mounting Ring:** Teflon® plasma-coated cast-iron
- Bellows:** Polyethylene
- Base:** Duratuff® II or cast-iron E-coating
- Clamps:** Stainless-steel
- Seals:** Low-swell nitrile



Lid Features

- ◆ **Simple “Plumbers Plug” Operation** – cover seal is expanded against mounting ring wall
- ◆ **Vertical Sealing Surface** – prevents gravel and debris from damaging or interfering with the cover seal
- ◆ **Machined Sealing Surface** – ensures watertight seal. Teflon®-coated stainless-steel
- ◆ **Field Replaceable Seal** – designed for all-weather performance
- ◆ **Clear Anodized Aluminum Top Plate** – deters cover theft
- ◆ **Potted Hinge Mechanism** – prevents ice and debris from hindering lever operation
- ◆ **Product Identification Tags** –

Additional Features

- available for both the spill-container cover and bucket to positively identify the product contained in the UST with standard API symbols (See product I.D. tag specification page for more information: page 87.)
- ◆ **Capacities** – 5- and 15-gallon
- ◆ **Fuel Compatibility** – designed to accommodate all fuels, including methanol, ethanol and MTBE
- ◆ **Highway 20 Rated (H20/HS20)** – all OPW spill-containers and manholes exceed the requirements of the Highway 20 rating

Listings and Certifications



Ordering Specifications

Plug or Drain-Valve Models

Model	Gal.	Liter	Base	Drain-Valve or Drain Plug	Cover	lbs.	kg
1SC-2100-DEVR	5	19	Composite	Drain-Valve	Aluminum	47	21
1SC-2115-DEVR	15	57	Composite	Drain-Valve	Aluminum	47	21
1SC-2100-PEVR	5	19	Composite	Drain Plug	Aluminum	47	21
1SC-2115-PEVR	15	57	Composite	Drain Plug	Aluminum	47	21
1SC-2100C-DEVR	5	19	Cast-Iron	Drain-Valve	Aluminum	53	24
1SC-2115C-DEVR	15	57	Cast-Iron	Drain-Valve	Aluminum	53	24
1SC-2100C-PEVR	5	19	Cast-Iron	Drain Plug	Aluminum	53	24
1SC-2115C-PEVR	15	57	Cast-Iron	Drain Plug	Aluminum	53	24

Dimensions

Slip-On Models (see drawing on right)

	1SC-2105		1SC-2155	
	in.	cm	in.	cm
A	16	41	16 ⁷ / ₃₂	41
B	14	36	22	56
C	1 ⁵ / ₃₂	3	1 ⁵ / ₃₂	3
D*	10 ¹ / ₁₆	25	14 ¹ / ₈	36
E*	17	43	21	53

*Subtract 2" from "E" dimension for Cast-Iron Base Models.

Thread-On Models (see drawing on right)

	1SC-2100		1SC-2115	
	in.	cm	in.	cm
A	16	40	16 ⁷ / ₃₂	41
B	14 ¹ / ₁₆	36	22	56
C	1 ⁵ / ₃₂	3	1 ⁵ / ₃₂	3
D	16 ³ / ₈	42	20 ¹ / ₂	52
E*	18 ⁵ / ₁₆	47	22 ¹ / ₂	57

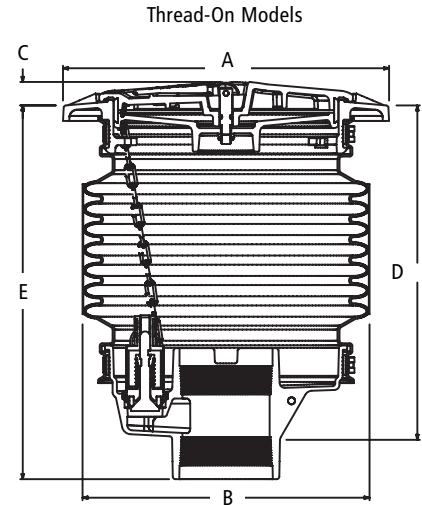

Sealable Covers

SC-WHITE	
SC-RED	
SC-YELLOW	
SC-ORANGE	
SC-BLACK	
SC-PLAIN	

Replacement Parts

Part #	Description
SC-PLAIN	Replacement Cover
H13931M	Cover Gasket
C04101B	Bronze Lever Arm
D01874M	Lower Plate
C04141M	Rubber Insert
H12927M	Adjustment Nut
1SC-TOOL	Optional Easy-Opening Tool
1DK-2100-EVR	Drain-Valve Kit

4" Threaded Nipples for Mating Spill Bucket to Adaptor

Part #	Description
TC-400	4" Torque Cap
H15144M	4" NPT Nipple, 4" Length
H12806M	4" NPT Nipple, 5" Length
VPN4X7	4" NPT Nipple, 7" Length
H15271M	4" NPT Nipple, 8" Length
H15268M	4" NPT Nipple, 10" Length

Sealable Cover Operation

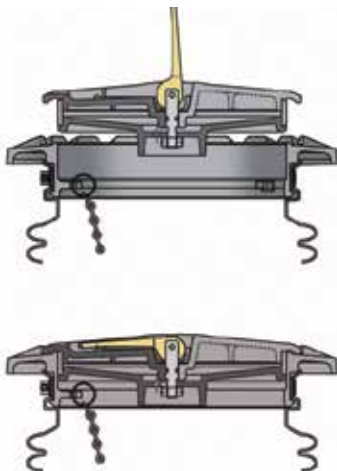

Lid in Closed Position



1DK-2100 Drain-Valve Kit
Instruction Sheet Order
Number: H11471M

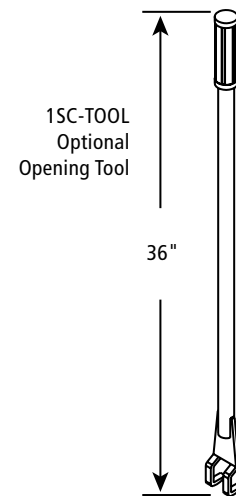

**OPW 1-2105 Series
Slip-On Spill-Containers**

OPW Slip-On Spill-Containment Manholes are used on new or existing UST riser pipes. The spill bucket slides onto 3" or 4" fill and vapor-return riser pipes and is then secured in place. Slip-on spill-containers provide a fast, economical way to replace uncontained manholes or fill boxes.

Materials

Cover: Cast aluminum or cast-iron

Mounting Ring: Duragard®-coated cast-iron

Bellows: Polyethylene

Base: Duratuff®

Clamps: Stainless-steel

Seals: Nitrile

1-2105, 5-Gallon
Slip-On Spill-Container



Features

- ◆ **Easy Installation** – clamps directly onto a 4" riser pipe. Reduces job-site time and installation costs; no need to remove, cut or thread riser pipe
- ◆ **Capacity** – available in a true 5-gallon capacity as well as a 15-gallon capacity
- ◆ **Rain-Shedding Cover** – available in either cast-aluminum or cast-iron, this unique design incorporates a seal in the underside of the cover. The seal seats between two dams on the mounting ring to prevent surface water from entering the spill-container
- ◆ **Fuel Compatibility** – designed to accommodate the fuels of the future, including methanol, ethanol and fuels with MTBE additives
- ◆ **Optional Suction Hand Pump** – 8 oz. per stroke capacity for high-speed evacuation of excess liquid. Allows user to pump product back into the tank or out of the spill-container for proper disposal
- ◆ **Product Identification Tags** – available for both the spill-container cover and bucket to positively identify the product contained in the UST with standard API symbols (See product I.D. tag specification page for more information: Page 101.)
- ◆ **Offset-Base Pipe Entry** – 1" offset allows for proper clearance with close fill/vapor riser spacing on tanks
- ◆ **Heavy-Duty Mounting Ring** – the angled ramp design offers superior protection against snow-plows and provides for secure concrete anchoring
- ◆ **Highway 20 Rated (H20/HS20)** – all OPW spill-containers and manholes exceed the requirements of the Highway 20 rating
- ◆ **Compatible with DEF fuels**

Spill-Container Slip-on Model
Instruction Sheet Order Number:
H12262M

**Listings and
Certifications**



Ordering Specifications

Model	Gal.	Liter	Cover	lbs.	kg
1-2105	5	19	Aluminum	39	18
1C-2105	5	19	Cast-Iron	53	24
1-2155	15	57	Aluminum	45	21
1C-2155	15	57	Cast-Iron	55	25
1SC-2105	5	19	Sealable	39	18
1SC-2115	15	57	Sealable	45	21

Replacement Parts/Accessories

Part #	Description	Part #	Description
1-21AC	Aluminum Cover w/ Seal	H12229M	Cover Seal
1-21CC	Cast-Iron Cover w/ Seal	201567	Inner Bellows
1P-2105	Optional Hand Pump Kit	201759	4 x 3 Reducer Insert

**OPW 1-2105 Series
Slip-On Spill-Containers**

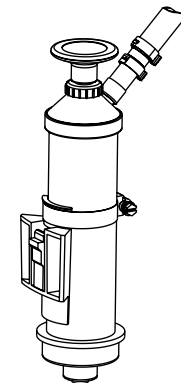
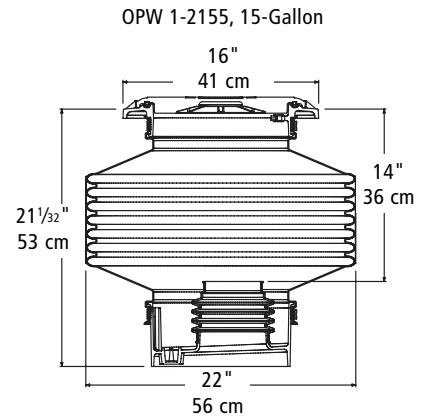
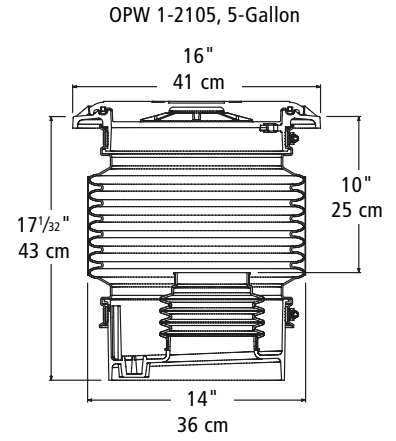

1P-2105 Suction Hand Pump

OPW 101BG-2100 Series Below-Grade Spill-Containers

OPW Below-Grade Spill-Containment Manholes are used in new tank or riser pipe installations. The watertight spill-containment chamber is installed completely below grade-level. A grade-level manhole cover lies flush with the driveway grade to reduce a tripping hazard and the potential for damage from snow-plows and traffic. Surface water drains into the backfill between the manhole skirt and the exterior of the containment bucket. Below-grade spill-containers are available in three ad-on and slip-on configurations in 5- and 15-gallon capacities.

101BG Slip-on Model Instruction Sheet Order Number: **H12579M**

101BG-2100 Instruction Sheet Order Number: **H12260M**

Important Notice: The OPW101BG-2100 Spill-Container Series does not prevent contamination of the soil or backfill resulting from spills flowing between the spill-container and the outer shell. Ground contamination may result if the spill-container is filled beyond capacity, or if a spill occurs outside the spill-containment cell.

- ◆ **Highway 20 Rated (H20/HS20)** – all OPW spill-containers and manholes exceed the requirements of the Highway 20 rating.

Materials

- Grade Cover:** Fiberglass-reinforced composite (steel optional)
- Lid:** Glass-reinforced composite
- Lever, top case:** Polyethylene
- Outer shell:** Polyethylene, powder-coated steel
- Containment cell:** Polyethylene
- Base:** Duratuff® II or cast-iron



Features

- ◆ **Pull-to-Open Drain-Valve** – allows high-speed drainage of excess product into the tank. Designed with a convenient self-cleaning seal and removable screen for easier component cleaning (CARB Approved)
- ◆ **Capacity** – 5-gallon and 15-gallon capacities
- ◆ **Outer Shell** – the outer shell isolates the containment vessel from the surrounding concrete and gravel. This high-density polyethylene shell is designed to provide space between the outer shell and the containment vessel to allow any surface water that enters to flow into the backfill, not the containment vessel. Elimination of water in the spill-container reduces product contamination and ice formation during cold winter months
- ◆ **Vapor-Tight Lid** – a unique, hinged and sealed containment-vessel lid provides a vapor-tight seal, designed to prevent vapors from escaping at ground level while eliminating the accumulation of dirt and water that contaminate fuel. Incorporating a special lid-interlock design, the grade-level cover cannot be replaced on the outer shell without the lever being in the closed and locked position
- ◆ **Composite Grade Level Cover** – made of sturdy fiberglass-reinforced composite, the grade cover is less prone to theft than aluminum covers, and lighter in weight than cast-iron. In addition, the cover lies flush with the actual grade so no ramps are required to support the cover, eliminating snow-plow hazards and “speed bumps” (Optional steel-plate cover is also available)
- ◆ **Fuel Compatibility** – designed to accommodate the fuels of the future, including methanol, ethanol and fuels with MTBE additives
- ◆ **Easy Installation** – reduces job-site time and installation costs. Simply thread the Duratuff® II base (cast-iron base is optional) onto a standard 4" Schedule 40 pipe. Guides are provided to assure proper positioning of the spill-container. The hinged lid orientation is adjustable during installation for site-specific placement
- ◆ **Product Identification Tags** – available for both the spill-container cover and bucket to positively identify the product contained in the UST with standard API symbols (See product I.D. tag specification page for more information: page 91.)

Listings and Certifications

CARB Certifications and Listings

101BG(S)-2100
101BG(S)-2115

Approval Letter #93-26



Ordering Specifications

Duratuff® II Base Models

Model	Gal.	Liter	Drain-Valve	lbs.	kg
101BG-2100	5	19	Pull	60	27
101BG-2105**	5	19	None	60	27
101BG-2115	15	57	Pull	65	29

**Slip-on Base

Cast-Iron Base Models

Model	Gal.	Liter	Drain-Valve	lbs.	kg
101BG-2100C	5	19	Pull	72	33
101BG-2115C	15	57	Pull	77	35

Dimensions

	101BG-2100		101BG-2115	
	in.	cm	in.	cm
A	20 ⁹ / ₁₆	52	20 ⁹ / ₁₆	52
B	17 ¹ / ₄	44	25 ¹ / ₂	65
C*	23 ²⁹ / ₃₂	61	27 ³¹ / ₃₂	71
D	22 ¹ / ₁₆	56	26 ⁵ / ₃₂	66

*Subtract 2" from "C" dimension for Cast-Iron Base Models.

Replacement Parts/Accessories

Part #	Description
1DK-2100-EVR	Pull Drain-Valve
101BG-21AR	Inside Hatch Height Extender
101BG-21LA	Red Lever & Crossarm Assembly
101BG-LATCH	Latch Kit; Yoke, Cotterpin & Spring
101BG-BUCKET	5 Gallon Replacement Spill Container
C04785M	5 Gallon Insert Support

Part #	Description
101BG-COVER	Composite Manhole Cover
E00491	Complete Replacement Top Assembly
H11671M	Steel Manhole Cover
H12280M	Ring Seal
H12620	Inside Hatch
P110-20LID	Steel Manhole Cover w/ID Tag System

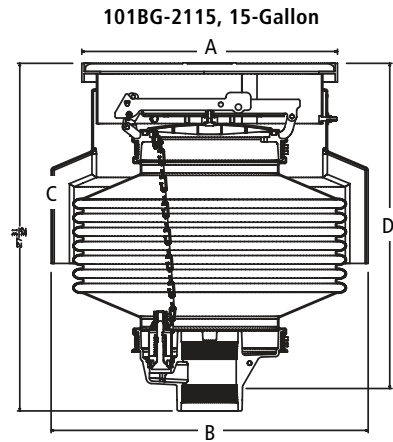
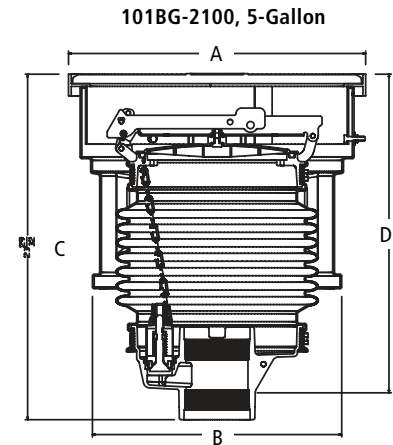

NOTE: "D" dimension is height from riser pipe to finish grade (+1" for slope)

Operation of 101BG Lid

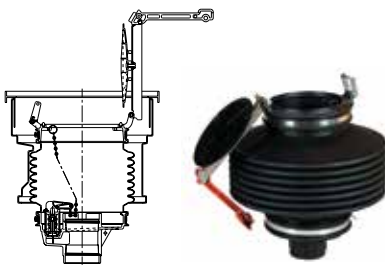

Lid and lever in open position.

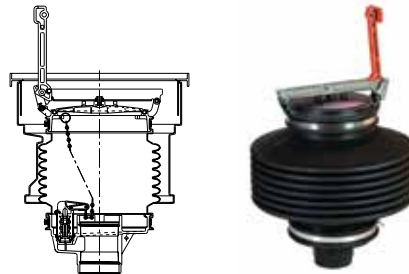

Lid down, but not closed. Lever still in upright position preventing replacement of grade cover.

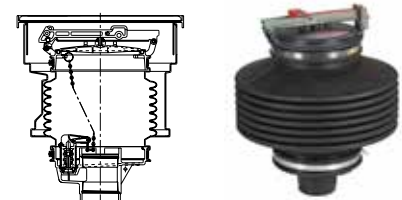

Lid and lever in closed and locked position. Grade cover now easily replaced on rim.

1DK-2100 Drain-Valve Kit Instruction Sheet Order Number: H11471M

OPW FibreTite Multiport Spill-Containment

OPW "FibreTite" Multiport Spill-Containment Manholes provide spill-containment for underground storage tank (UST) fill pipes and vapor recovery risers.

Multiports are installed over the top of tank sumps to preserve future access to the tank top and to facilitate containment of tank-bung fittings.

OPW "FibreTite" watertight covers are easy to remove. The composite manhole covers are available with center or offset port for access to fill risers.



Materials:

- Cover: Fiberglass
- Frame: Fiberglass
- Skirt: Fiberglass

Features & Benefits:

- ◆ Lightweight - reduce risk of back, foot and hand injuries
- ◆ UV resistant
- ◆ Standard duty (20-ton load rating)
- ◆ No bolts required to seal top cover
- ◆ Anti-slip surface
- ◆ Composite construction; does not corrode
- ◆ Watertight, sealed design
- ◆ Monolithic structure eliminates delaminating
- ◆ Ergonomic, single-person removal and replacement with Fibrelite lifting handle
- ◆ Easy access watertight sump inspection port
- ◆ Replaceable double-wall spill-containment
- ◆ Easy access to overfill-prevention valve

OPW FibreTite Multiport and Sump System Kit

Includes:

- Multiport Cover
- Spill-Containers
- Clamping Kits
- Top Hat
- Frame
- Port Covers
- Water-Spill Platform
- Sump Base
- Skirt
- Shroud Boot

FibreTite Multiport Spill-Containment Ordering Specifications

FTSX-XXXX XX - XXXXXX - X (X)

BASE DEPTH
 M - Medium Bury (54" depth)
 D - Deep Bury (64" depth)

BASE DIAMETER
 4237 - 42" Base & 37" Opening
 4837 - 48" Base & 37" Opening

BASE MOUNTING
 CR - Collar Ring
 SB - Solid Bottom
 RF - Reverse Flange

COVER CONFIGURATION
 MP3716S - Multiport @ 16" Centers
 SB - Solid Bottom
 OF378S - Offset @ 8" offset

PORTCOVER COLOR
 BL - Black/Orange Cover
 B - Blue/Orange Cover
 G - Gray/Orange Cover
 GR - Green/Orange Cover
 O - Orange/Orange Cover
 R - Red/Orange Cover
 W - White/Orange Cover
 Y - Yellow/Orange Cover

*Note: OF378S cover configuration will NOT include the Orange cover

PORTCOVER OPTION
 BLANK - FC-11 Cover
 SC - Powder-Coated Sealable Cover

All Fill & Vapor Covers ship with Composite FC-11 Spill Port Covers.*

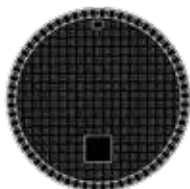

Add "SC" to the end of the part for Sealable Covers.



Listings and Certifications



*Does not come with FLMP-IP as pictured. Must order separately.

New Style

OPW FibreTite Multiport Kit to Install on Existing Tank Sump



Includes Spill-Containers

Kit includes; Multiport Cover, Frame, Skirt, Spill-Containers, Port Covers, Shroud Boot, Clamping Kits, Water-Spill Platform and Top Hat

Ordering Specifications

Part Number	Application	WT Cover	Bonded Manhole			
			Round Sump Riser Diameter	Skirt ID	FRP Cover	Fill & Vapor Cover
S42-3100G-MP3716S-W	5 Gallon Regular Gasoline MP System	37" WSP37-16S	42"	40"	Gray	White/Orange
S42-3100G-MP3716S-R	5 Gallon Premium Gasoline MP System	37" WSP37-16S	42"	40"	Gray	Red/Orange
S42-3100G-MP3716S-BU	5 Gallon Mid-Grade Gasoline MP System	37" WSP37-16S	42"	40"	Gray	Blue/Orange
S42-3100G-OF378S-Y	5 Gallon Diesel Offset System	37" WSP37-8S	42"	40"	Gray	Yellow
S48-3100G-MP3716S-W	5 Gallon Regular Gasoline MP System	37" WSP37-16S	48"	40"	Gray	White/Orange
S48-3100G-MP3716S-R	5 Gallon Premium Gasoline MP System	37" WSP37-16S	48"	40"	Gray	Red/Orange
S48-3100G-MP3716S-BU	5 Gallon Mid-Grade Gasoline MP System	37" WSP37-16S	48"	40"	Gray	Blue/Orange
S48-3100G-OF378S-Y	5 Gallon Diesel Offset System	37" WSP37-8S	48"	40"	Gray	Yellow



Replacement for Existing FL100 MP System includes Spill-Containers

Kit includes; Multiport Cover, Spill-Containers, Port Covers, Shroud Boot, Clamping Kits and Water-Spill Platform

Ordering Specifications

Part Number	Application	WT Cover	Bonded Manhole			
			Skirt ID	FRP Cover	Fill & Vapor Cover	
FL100G-RETRO-MP3716S-W	5 Gallon Regular Gasoline MP System	37" WSP37-16S	40"	Gray	White/Orange	
FL100G-RETRO-MP3716S-R	5 Gallon Premium Gasoline MP System	37" WSP37-16S	40"	Gray	Red/Orange	
FL100G-RETRO-MP3716S-BU	5 Gallon Mid-Grade Gasoline MP System	37" WSP37-16S	40"	Gray	Blue/Orange	
FL100G-RETRO-OF378S-Y	5 Gallon Diesel Offset System	37" WSP37-8S	40"	Gray	Yellow	

Multiport Kit Only, No Sump Includes Spill-Containers

Kit includes; Multiport Cover, Frame, Skirt, Spill-Containers, Port Covers, Shroud Boot and Clamping Kits

Ordering Specifications

Part Number	Application	Skirt ID	FRP Cover	Fill & Vapor Cover
FL100GRAY-MP16S-SK12-R	5 Gallon Premium Gasoline MP System	40"	Gray	Red/Orange
FL100GRAY-MP16S-SK12-BU	5 Gallon Mid-Grade Gasoline MP System	40"	Gray	Blue/Orange
FL100GRAY-OF8S-SK12-Y	5 Gallon Diesel Offset System	40"	Gray	Yellow

Replacement Parts/Accessories

Part Number	Description
P761C-FLDV	5 Gallon Fill Bucket for Fibrelite MP with Drain-Valve and Cast-Iron Base
P761C-FLPL	5 Gallon Vapor Bucket for Fibrelite MP with Plug and Cast-Iron Base
FC-11-Orange	11" Orange Vapor Cover
FC-11-RED	11" Red Fill Cover
FC-11-WHITE	11" White Fill Cover
FC-11-YELLOW	11" Yellow Fill Cover
FC-11-BLUE	11" Blue Fill Cover
FL100GRAY-MP16S*	FL100 Gray Composite Multiport Cover- 16" Centers
FL100GRAY-OF8S	FL100 Gray Composite Cover Offset Port

Part Number	Description
FLMP-SB	MPS Shroud Boot Kit (Includes WSP-CRKS, Clamp Kit)
FLMP-IP	Inspection Port Kit for Fibrelite Multiport
FC-11-SEAL	Seal for FC-11 Covers
WSP37-8S	37" Multiport Water Shroud for Single Offset Port
WS-RING-37	37" Dia. Stainless-Steel Retaining Ring Kit
S-CR-FGK	FRP Kit for Bonding Collar Ring Sump to FGFR Tank Collar (Includes Resin, Catalyst & Glass Tape)
S-TH-FGK	FRP Kit for Top Hat to Sump (Includes Resin, Catalyst & Glass Tape)
RK-5000	Fiberglass Epoxy Kit (Qt. Size)
211300	Epoxy pack to bond 1TAG to composite cover

* Does not come with FLMP-IP as pictured. Must order separately.

See 1TAG section for I.D. markers for new multiport

Spill-Container



Replacement Fill Cover*

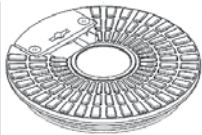

Replacement 2-Port Cover



Old Style

Fibrelite Multiport without Inspection Port Replacement Parts/Accessories

Part Number	Description
P711-EVRDV	5 Gal. Spill Bucket, Composite Base, Drain-Valve
P711-EVRPL	5 Gal. Spill Bucket, Composite Base, Plug
P761C-EVRDV	5 Gal. Spill Bucket, Cast-Iron Base, Drain-Valve
P761C-EVRPL	5 Gal. Spill Bucket, Cast-Iron Base, Plug
P511-15-EVRDV	15 Gal. Bucket w/Drain-Valve, Composite Base
FC-10-BLACK	10" Black Fill Cover
FC-10-BLUE	10" Blue Fill Cover
FC-10-GRAY	10" Gray Fill Cover
FC-10-ORANGE	10" Orange Fill Cover
FC-10-RED	10" Red Fill Cover
FC-10-WHITE	10" White Fill Cover
FC-10-YELLOW	10" Yellow Fill Cover
FC-10-SEAL	Replacement Gasket For FC -10 Covers

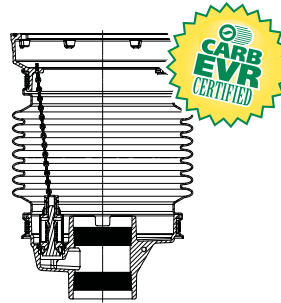

5-Gallon Fill or Vapor Spill Bucket

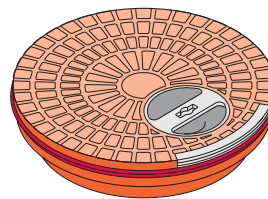

Replacement FC-10 Fill-Port Covers

Ordering Specifications

Multiport Watertight Spill Platform

Part #	Application	Dia.	Height	Base	Weight (lbs)
WSP33-16	Dual Access Ports 16" Centers Slope to Fill bucket	34.75"	(2) 5 Gallon	16" Center	13
WSP33-8	Single Access Port At 8" Off Center Slope to Fill bucket	34.75"	(1) 5 Gallon	8" Offset	13
WSP37-16	Dual Access Ports At 16" Center Slope to Fill bucket	38.25"	(2) 5 Gallon	16" Center	17
WSP37-8	Single Access Port At 8" Off Center Slope to Fill bucket	38.25"	(1) 5 Gallon	8" Offset	17
WTS37-16	Dual Access Ports At 16" Center No Slope to Fill bucket	38.25"	(2) 5 Gallon	16" Center	17
WTS37-8	37" Dia Single Access Port At 8" Center No Slope to Fill bucket	38.25"	(1) 5 Gallon	8" Offset	17

All Multiport Platforms include WSP/CRK bucket clamping Kits

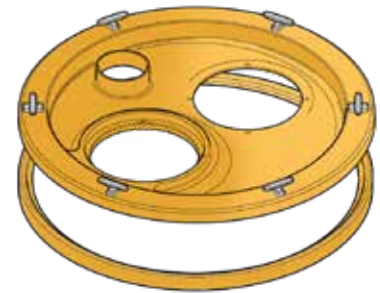

Replacement Parts

Part #	Description
WSP-WTS-OPC	6" Observation Port Cap
WTS-CAP-14	14" Container Port Cap
209939	Replacement Handle for FC10 Cover

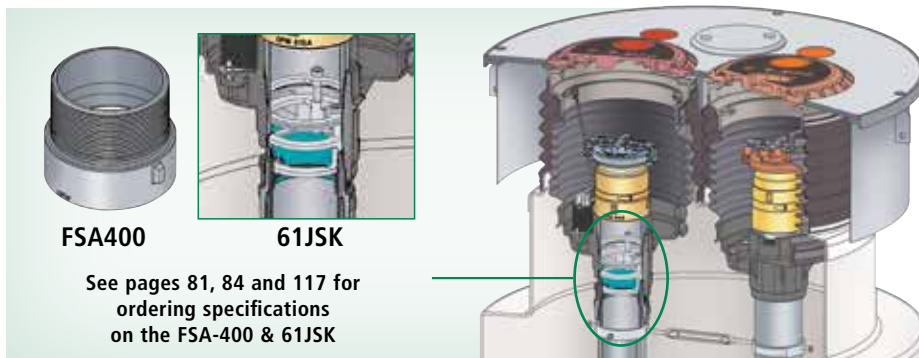

FSA400

61JSK

See pages 81, 84 and 117 for ordering specifications on the FSA-400 & 61JSK

OPW 400 and 500 Series Multiport Spill-Containment Manholes

OPW Multiport Spill-Containment Manholes provide spill-containment for underground storage tank (UST) fill pipes and vapor recovery risers in a completely integrated single manhole package. Multiports are installed over the top of tank sumps to preserve future access to the tank top and to facilitate containment of tank-bung fittings. OPW offers a vast array of standard multiport configurations and options, in addition to an almost unlimited ability to provide custom solutions for virtually any spill-containment application.

- ◆ **Spill-Container Cover Options** – standard spill-container options include the patented OPW dam-and-groove rain-tight (RT) design and the watertight Sealable Cover (SC) “plumber’s plug” design. The rain-tight cover features a finger-grip lifting facility and an integral seal. The Sealable Cover features a cam-operated mechanism that expands the seal against the vertical wall of the mounting ring. Both of these water-shedding covers are protected by raised mounting rings.
- ◆ **Fastener Options** – two types of fasteners are available to secure the manhole lid and monitoring port to mounting rings. Standard are 5/16" -18 hex-head bolts. Optional are OPW Roto-Lock Fasteners. The OPW Roto-Lock system enables a secure, watertight connection without the need to locate threaded bolt holes on the mounting ring.
- ◆ **Powder-Coated Rings & Covers** – available upon request.
- ◆ **Replacement Covers** – see Part Number Configurations at www.opwglobal.com.

Listings and Certifications



CARB EVR Executive Order #VR-102
NYCFD Certified (6571Series) #5053
Florida EQ-145

Model Descriptions

- ◆ **OPW 411 Series** – features a flush-mounted manhole lid and raised dual dam-and-groove-spill-container rings, with P2105 Buckets using OPW 1-2105 Style Slip-On 5-gallon containers. Base is standard 1" offset from center and can be used for 12", 14", 16" or wider riser spacing. Optional 1P-2105 Hand Pump available
- ◆ **OPW 500 Series (511 / 521) EVR Multiport** – features a flush-mounted manhole lid and raised dual dam-and-groove-spill-container ring, with P511-EVR Buckets using OPW 1-2100 Style Thread-On Spill-Containers. All Fill Ports in these spill-containers feature an enhanced 1DK-2100-EVR vapor-tight drain valve. The Vapor Return Spill-Container features a permanent plug in the drain port as per EVR requirements. EVR Multiport Thread-On On Spill Containers are available in composite or cast-iron bases with 5-gallon buckets. Drain-Valve Spill Bucket & Plug Spill Bucket standard on Dual Ports, Drain-Valve Spill Bucket standard on Single Port
- ◆ **Required for EVR APPLICATIONS** – the FSA-400 Threaded Riser Face Seal Adaptor is installed on the fill pipe below the spill-container to provide a true sealing for the drop tube flange on the 7150 overfill-prevention valve. The 6150 and/or 7150 series valve is installed in the base of the OPW EVR spill-container with the patent-pending 61JSK jack screw device. This configuration allows liquid in the spill-container to be drained directly into the drop tube, thereby isolating the drain valve from the tank ullage, eliminating a notorious leak point in previous systems

Features

- ◆ **Contractor-Friendly Installation** – studded mounting ring simply bolts together inside the spill-containment bucket. No need to align bolt holes in the manhole cover
- ◆ **Rain-tight Service** – nitrile gaskets on the manhole and spill-bucket mounting rings help prevent contamination of the sump area from surface water intrusion
- ◆ **Highway 20 Load Rating** – the rugged diamond plate steel manhole covers, as well as the ductile iron (RT) or aluminum (SC) spill-container covers meet H20/HS20 Load Rating requirements
- ◆ **Spill-Container and Manhole Positive I.D. System** – special recesses cast into spill-container covers allow product I.D. tags to be attached to the lids. Matching bucket tags can be affixed to the inside of the spill container to prevent covers from getting switched
- ◆ **Fill/Vapor Ports** – configurations are available to accommodate a single fill riser, dual ports for both a fill and vapor riser, and triple and quad ports for multiple fill and vapor risers. Ports can be supplied with or without containment buckets
- ◆ **Port Configurations** – standard port locations match the popular riser spacings (16" or 24") and bung configurations on underground storage tanks. Custom port locations are easily accommodated. For riser spacings less than 16", old-style buckets must be used
- ◆ **CARB Certified** – 500 Series CARB EVR Approved Executive Order #VR-102
- ◆ **Manhole Cover Sizes** – standard bolt-down manhole cover diameters of 30" (76 cm), 37" (94 cm), 42" (107 cm) and 48" (122 cm) allow ample access to the sump area. Heavy-duty reinforced lid options are also available upon request

OPW Multiport Spill-Containment Ordering Specifications

EVR Multiports

Thread-On Spill-Containers are available in composite or cast-iron bases with either 5- or 15-gallon buckets. (1) Drain-Valve Spill Bucket & (1) Plug Spill Bucket standard on Dual Ports. Drain-Valve Spill Bucket standard on Single Port.

Fill/Vapor Port Configurations

A (Dead Center) B (Dead Center)
E (Offset Single Port) G (42" Minimum Cover)
L (Offset Single Port) T (Offset Single Port)

NOTE: 43 or 49 style Gauge Port must be used if a water shroud is to be used with L style

Riser Spacing

00 - Single Port (A Configurations)
16 - 16" Centers
24 - 24" Centers
(42" Minimum Cover)

Manhole Cover Size*

30" (Configurations)
36 - 36" Retrofit Only
37 - 37"
39 - 39" Retrofit Only
42 - 42"
48 - 48"
* 42" is standard

411-5-gallon (Slip-On)
511-5-gallon (Thread-On)

Spill-Container Capacity***

00 - No Containment
05 - 5-Gallon
15 - 15-Gallon
*** 5-Gallon bucket is standard

Powder Coated Manhole Covers

R - (1) Red
(1) Orange
W - (1) White
(1) Orange
Y - (1) Yellow

Product Number

6 - **EVR** -

Bolt Down Model Number

511EVR - HDPE Bellows, Thread-On Composite Base, Bolt-Down
561EVR - HDPE Bellows, Thread-On Cast-Iron Base, Bolt-Down

Roto-Lock Model Number

521EVR - HDPE Bellows, Thread-On Composite Base, Roto-Lock
571EVR - HDPE Bellows, Thread-On Cast-Iron Base, Roto-Lock

Optional Roto-Lock Fastner System

The OPW Roto-Lock system enables a secure rain-tight connection without the need to locate threaded bolt holes on the mounting ring.

Replacement / Retrofit Manhole RP* - (No Ring / Skirt)

OPW recommends a field survey form on custom RP covers. Incorrect custom models are not eligible for return.

Gauge Port Location

00 - No Gauge Port
40 - Port at 12 o'clock
43 - Port at 3 o'clock
46 - Port at 6 o'clock
49 - Port at 9 o'clock
4M - Port in Center
7X - Flush Mount

NOTE: 3M-Style gauge port must be used with port in the center of "G" Style

Spill-Container Cover Style**

RT - Rain-tight
SC - Sealable Cover
00 - No Ring or Cover

RT - Rain-tight
SC - Sealable Cover (Lid in open position)
** Rain-tight cover is standard

Of Ports With Containment

0
1
2
3
4

Current Replacement Parts

For New 500 Series EVR Multiports 6511/6521, 6561/571 made post 11/2003

Part #	Description
P711-EVRDV	Replacement 5-Gallon Bucket, w/ Drain-Valve
P711-EVRPL	Replacement 5-Gallon Bucket, w/ Plug (Vapor)
P761C-EVRDV	Replacement 5-Gallon Bucket, C.I. Base w/ Drain-Valve
P761C-EVRPL	Replacement 5-Gallon Bucket, C.I.
P411-EVRPL	Replacement 5-Gallon Slip-On Bucket
P511-15-EVRDV	Replacement 15-Gallon Bucket, Comp Base, W/ Drain-Valve
C05170M	Gasket, Spill Bucket & Mounting Ring
H15187M	Replacement Seal for New Rain Tight Cover

Note: New P711 & P761 EVR buckets will only work with New "EVR" Multiport covers. (made post 11/2003)

See page XX for replacement rings and covers part numbers.

Dimensions

O.D.		I.D.		Thickness	
in.	cm	in.	cm	in.	cm
30	76	26 ⁵ / ₈	68	3 ⁷ / ₈	0.952
37	94	34 ⁵ / ₈	88	3 ⁷ / ₈	0.952
42	107	39 ⁵ / ₈	101	1 ¹ / ₂	1.27
48	122	44 ⁵ / ₈	113	1 ¹ / ₂	1.27

Optional Accessories

Part #	Description
6511-RB16	12" to 18" Riser Spacer
6511-RB24	20" to 26" Riser Spacer
H15144M	4" NPT Nipple, 4" Length
H12806M	4" NPT Nipple, 5" Length
VPN4X7	4" NPT Nipple, 7" Length
H15271M	4" NPT Nipple, 8" Length
H15268M	4" NPT Nipple, 10" Length
TC-400	4" Torque Cap for 16" Nipples
6521-XAR37	36", 37" OR 38" Roto-Lock Adaptor Ring to convert from Bolt Down
6521-XAR42	39" OR 42" Roto-Lock Adaptor to convert from Bolt Down
6521-XAR48	48" OR 52" Roto-Lock Adaptor to convert from Bolt Down



See page 94 for additional cover options.
See page 95 for replacement cover options.

OPW Multiport Spill-Containment Replacement Parts

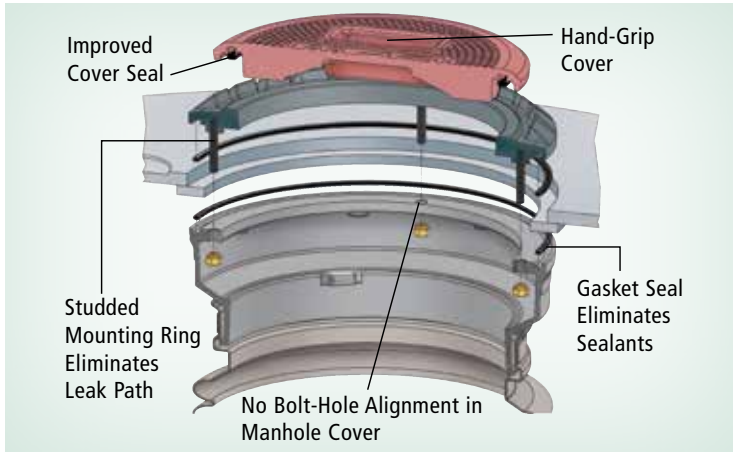

Current Replacement Parts

For New 500 Series EVR Multiports 6511/6521, 6561/571 made post 11/2003

Part #	Description
P711-EVRDV	Replacement 5-Gallon Bucket, w/ Drain-Valve
P711-EVRPL	Replacement 5-Gallon Bucket, w/ Plug (Vapor)
P761C-EVRDV	Replacement 5-Gallon Bucket, C.I. Base w/ Drain-Valve
P761C-EVRPL	Replacement 5-Gallon Bucket, C.I.
P411-EVRPL	Replacement 5-Gallon Slip-On Bucket
P511-15-EVRDV	Replacement 15-Gallon Bucket, Comp Base, W/ Drain-Valve
C05170M	Gasket, Spill Bucket & Mounting Ring
H15187M	Replacement Seal for New Rain Tight Cover

Note: New P711 & P761 EVR buckets will only work with New "EVR" Multiport covers. (made post 11/2003)

See page XX for replacement rings and covers part numbers.

Old-Style Replacement Parts

311/411/511/521 Series Multiports

Note: 511/521 parts are for Multiports made prior to Nov. 2003

Part #	Description
1DK-2100-EVR	511/521 Series Drain-Valve
H13931M	Replacement Seal for SC Cover
P110-37G	34" - 37" Manhole Gasket
P110-42G	42" Manhole Gasket
P110-48G	48" Manhole Gasket
PROTO-LOCK	(1) Roto-Lock
P40-ROTOLID	Replacement 40 Style Gauge Port Roto-Lock Lid
H15240M	Replacement Gasket for 40 Style Gauge Port
ALL C05501	Flush Mount Gauge Port Cover Only
P571-GK3T	Gasket Kit For New Style 571 Roto Multiport
203148	Replacement 3M Style Bolt Down Gauge Port, 4.8" diameter
205322	Replacement 30 Style Bolt Down Gauge Port, 6.5" diameter
P311-G	Bucket Top Flange Gasket
P511BUCKETBOLT	Spill Bucket RT Ring Kit (4) Bolts, Washers & Gaskets
H15238M	Replacement Gasket, 30 Style (Bolt Down)
1-2100-DSH	5 Gallon Fill Bucket with Composite Base & Drain-Valve
1-2100-PSH	5 Gallon Vapor Bucket with Composite Base & Plug

Part #	Description
411 P2105BUCKET	411 Replacement Bucket 5-Gallon
Parts 1P-2105	Hand Pump Kit for 411/P2105
P111-WTL	Replacement Cover (RT)
P111WTL-S	Replacement Seal for RT Cover
P311-1R	Replacement RT Ring
P311-14	RT Ring for 14" Riser
P511YBUCKET	Replacement Waste Oil Bucket
P511-DEVRBUCKET	Replacement 5-Gallon Bucket with Drain-Valve
P511-G14	Bucket Top Flange Gasket for Notched Gasket Set
P511-PEVRBUCKET	Replacement 5-Gallon Bucket with Plug
P511C-DEVRBUCKET	Replacement 5-Gallon Bucket With C.I. Base & Drain-Valve
511/521 P511C-PEVRBUCKET	Replacement 5-Gallon Bucket With C.I. Base & Plug
Parts P511-DEVRB-14	Replacement 5-Gallon Bucket with Drain-Valve 12" & 14" Risers
P511-PEVRB-14	Replacement 5-Gallon Bucket with Plug - 12" & 14" Risers
P511C-DEVRB-14	Replacement 5-Gallon Bucket W/ C.I. Base, Drain-Valve for 12" & 14" Risers
P511C-PEVRB-14	Replacement 5-Gallon Bucket W/ C.I. Base, Plug, for 12" & 14" Risers
P521-GKIT	521 Multiport Complete Gasket Kit
P511-GKIT	511 Multiport Complete Gasket Kit

See page 94 for additional cover options.

See page 95 for replacement cover options.

Multiport Manhole Water-Shroud System Option

The new OPW Multiport Manhole Water-Shroud System (MPWS) is designed to completely isolate surface water and condensation from the tank sump. The MPWS features an injection-molded fiberglass Water-Shroud lid that mates to a standard tank sump top hat reducer. This new bolt-down design allows even compression to facilitate watertight sump access. Shroud Boots isolate the spill-container buckets using stainless-steel band clamps, which provide a tight seal between the water shroud top hat and the underside of the spill-container mounting rings. A 6" Sump Inspection Port is provided on each FRP Cover, allowing full inspection access through the Multiport Gauge Port. The OPW Water-Shroud system is available in 33" and 36" models. The MPWS Water-Shroud is sold separately.

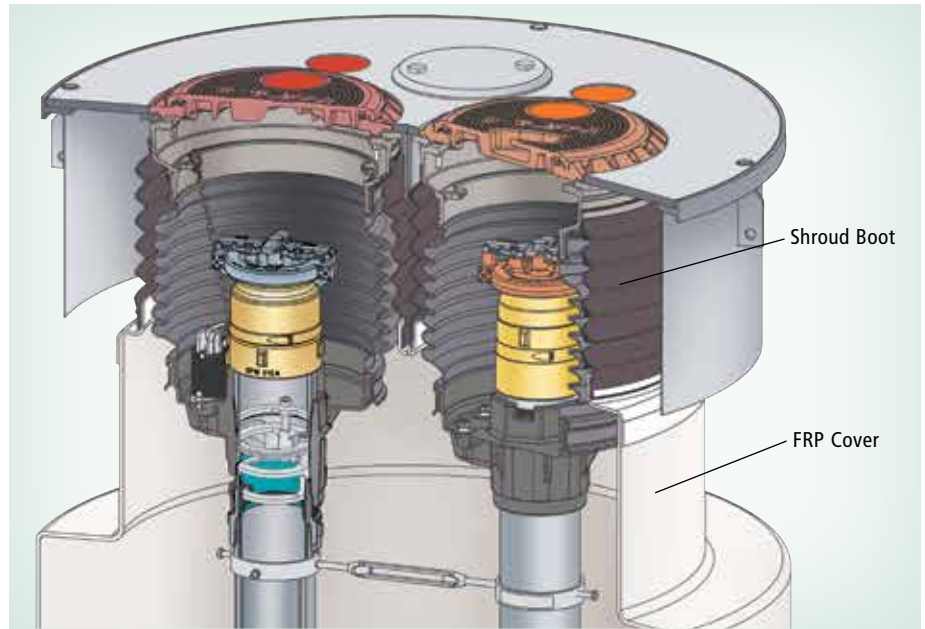

Ordering Specifications

Part #	Description
MPWS-33	33" FRP Cover with (2) 5-gallon Water Shroud Boots & Clamps
MPWS-33BD	33" Bolt Down Water Shroud
MPWS-33BDD	33" Bolt Down Water Shroud for Diesel
MPWS-36	36" FRP Cover with (2) 5-gallon Water Shroud Boots & Clamps
MPWS-39BD	39" 4-Port Bolt Down Water Shroud

Replacement Parts

Part #	Description
C05223M	Shroud Boot Cap to Isolate One FRP Cover Port
D02571M	33" FRP Replacement Cover
D02575M	5-Gallon Shroud Boot
H15187M	Rain-tight Cover Replacement Gasket
H15188M	Lower Clamp for 5-Gallon Shroud Boot
H15190M	Upper Clamp for 5 or 15-Gallon Shroud Boot
SIP-6	6" Sump Inspection Port Sight Glass
SLPK	Gasket and Sealant Kit for Shroud
201393	36" FRP Replacement Cover
205181	Lower Clamp for 5 Gallon Shroud
205183	Upper Clamp for 5 Gallon Shroud
H15187M	Rain-tight Cover Replacement Gasket
C05170M	O-Ring for Sealable and Rain-tight Ring



Rubber Shroud Cap



Shroud Boots Vinyl Plastisol



Sump Inspection Port (SIP) – Clear ABS Construction Inspection Port



FRP Cover Injection Molded Fiberglass Cover

Listings and Certifications

Florida EQ-145 NY Approval



NOTE: Part numbers do not include rings or covers. Rings and Covers must be ordered separately.

Bolt-Down Manhole Water-Shroud System Option

The Bolt-Down Multiport Water Shroud (MPWS-BD) is designed to mate with the OPW Multiport. The MPWS-BD isolates surface water and condensation from Tank Sumps.

Shroud boots isolate the spill-container buckets using stainless-steel band clamps, providing a tight seal between the water-shroud top hat and the underside of the spill-container-mounting ring. Bolts on the outer edge of the shroud cover secure it to the top hat. Available in 33" and 39" diameter covers.

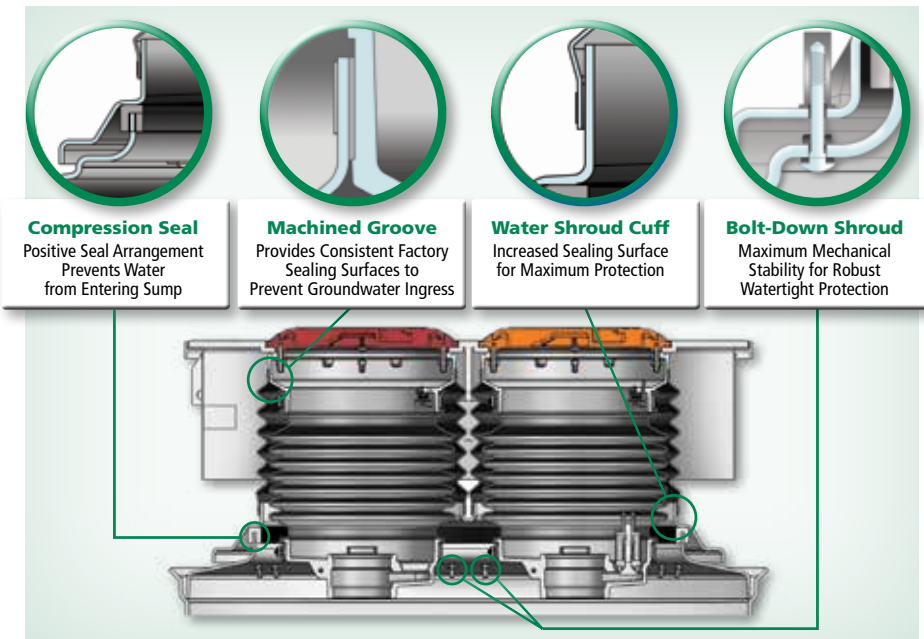

Compression Seal
Positive Seal Arrangement Prevents Water from Entering Sump

Machined Groove
Provides Consistent Factory Sealing Surfaces to Prevent Groundwater Ingress

Water Shroud Cuff
Increased Sealing Surface for Maximum Protection

Bolt-Down Shroud
Maximum Mechanical Stability for Robust Watertight Protection

New Ring and Cover Part Numbers

Rain-tight Covers	Rain-tight Cover Rings	Sealable Covers	Sealable Cover Rings
RTC-WHITE	RTR-WHITE	SC-WHITE	SCR-WHITE
RTC-RED	RTR-RED	SC-RED	SCR-RED
RTC-YELLOW	RTR-YELLOW	SC-YELLOW	SCR-YELLOW
RTC-GREEN	RTR-GREEN	SC-ORANGE	SCR-ORANGE
RTC-ORANGE	RTR-ORANGE	SC-BLACK	SCR-BLACK
RTC-BLACK	RTR-BLACK	SC-PLAIN	

Ordering Specifications

Part #	Description
203246	42" x 33" FRP Bolt-Down Top Hat
203272	42" x 39" FRP Bolt-Down Top Hat

OPW 106 Identification Marker

OPW 106 Identification Markers are used to identify the grade product stored in underground tanks. These markers are easily set in concrete, and once set, are permanent. The letter plate is recessed into the face of the base and fastened with two screws. The raised letters are easy to change when the product is changed. Letters available are P, R, U, SU, X, DL. Numbers 1, 2, 3, 4.

Materials

- Base And Anchor Shank: Aluminum
- Letter Plate: Cast aluminum
- Screws (2): Brass

Ordering Specifications

Product #	Fuel Type	lbs.	kg
106DL-0095	Diesel	.43	.20
106P-0150	Premium	.41	.19
106R-0175	Regular	.44	.20
106SU-0185	Super Unleaded	.43	.20
106U-0125	Unleaded	.44	.20



Product #	Fuel Type	lbs.	kg
106UP-0125	Unleaded "Plus"	.44	.20
106N-1100	I.D. Marker #1	.44	.20
106N-2200	I.D. Marker #2	.44	.20
106N-3300	I.D. Marker #3	.44	.20
106N-4400	I.D. Marker #4	.44	.20

OPW 107 Nameplate Holder

OPW 107 Nameplate Holders, when secured to storage tank fill pipes, provide a method to permanently identify the product in the tanks.

Materials

- Plate: Plated steel
- Straps: Plated steel

Ordering Specifications

Product #	in.	mm	lbs.	kg
107-0300	4	102	.39	.18

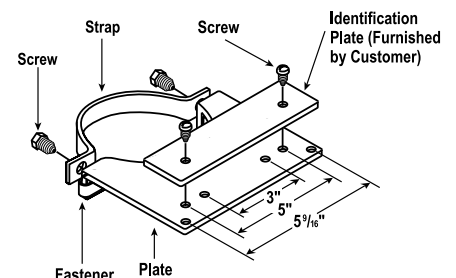

API Color Standard–
On Bucket ID Tag - Adhesive



Ordering Specifications

Adhesive Tag Part #	Description
1TAG-API-RG0	Regular Gasoline E0
1TAG-API-MG0	Midgrade Gasoline E0
1TAG-API-PG0	Premium Gasoline E0
1TAG-API-RG10	Regular Gasoline E10
1TAG-API-MG10	Midgrade Gasoline E10
1TAG-API-PG10	Premium Gasoline E10
1TAG-API-RF0	Racing Fuel E0
1TAG-API-RF10	Racing Fuel E10
1TAG-API-E15	Gasoline E15
1TAG-API-E25	Gasoline E25
1TAG-API-E85	Gasoline E85
1TAG-API-BD5	Up to 5% Biodiesel
1TAG-API-BD20	B20 Biodiesel
1TAG-API-OFF	Offroad Diesel (up to 5%)
1TAG-API-OFFB5	Offroad Biodiesel 5%
1TAG-API-DEF	Diesel Exhaust Fluid
1TAG-API-Kero	Kerosene
1TAG-API-MW	Monitoring Well
1TAG-API-VR	Vapor Recovery

API Color Standard–
On Bucket ID Tag - Hanging Tag



Ordering Specifications

Hanging Tag Part #	Description
1TAG-API-RG0T	Regular Gasoline E0
1TAG-API-MG0T	Midgrade Gasoline E0
1TAG-API-PG0T	Premium Gasoline E0
1TAG-API-RG10T	Regular Gasoline E10
1TAG-API-MG10T	Midgrade Gasoline E10
1TAG-API-PG10T	Premium Gasoline E10
1TAG-API-RF0T	Racing Fuel E0
1TAG-API-RF10T	Racing Fuel E10
1TAG-API-E15T	Gasoline E15
1TAG-API-E25T	Gasoline E25
1TAG-API-E85T	Gasoline E85
1TAG-API-BD5T	Up to 5% Biodiesel
1TAG-API-BD20T	B20 Biodiesel
1TAG-API-OFFT	Offroad Diesel (up to 5%)
1TAG-API-OFFB5T	Offroad Biodiesel 5%
1TAG-API-DEFT	Diesel Exhaust Fluid
1TAG-API-KeroT	Kerosene
1TAG-API-MWMT	Monitoring Well
1TAG-API-VRT	Vapor Recovery

Spill-Container Product
Identification Tags

OPW Color-Coded Spill-Container Tags positively and conspicuously identify tanks, preventing costly and dangerous product-drop mistakes. Simply “peel and stick” the high-visibility color inserts into the special recesses cast into the spill-container cover.

Matching bucket tags, supplied with tie wraps, are permanently affixed inside the spill-container to help prevent covers from getting switched.

Features

- ◆ **Unique Fiberglass Embedment Process** - ensures that the color identifiers won't scratch, crack, peel, weather or fade, even in gasoline and the harshest of environments
- ◆ **Compatible** – with all OPW 1-2100, 1-2200 and 1-3100 Series Spill-Containers, including aluminum, cast-iron, sealable cover and 101BG Composite Cover models. Also compatible with 111 Series, Multiport Spill-Containers and OPW 104FG/104C Manhole Covers
- ◆ **Available in All API Product I.D. Designations**

UST Fill-Pipe Connection Equipment

Tight-Fill Adaptors and Caps

Tight-Fill Adaptors are installed in spill-containment manholes on the fill riser pipe from an underground fuel-storage tank. They mate with the gravity-drop delivery elbow on the transport truck. Tight-Fill Caps are installed on adaptors, when not in use, to prevent gasoline vapors from escaping and to prevent water, dust and debris from entering the tank.

Stage I Vapor Recovery Adaptors and Caps

Stage I Vapor Recovery Adaptors are installed in spill-containment manholes on the vapor recovery riser pipe from an underground gasoline-storage tank. They mate with the vapor recovery elbow on the delivery transport truck when recovery of gasoline vapors is required. Stage I Caps are installed on adaptors, when not in use, to prevent gasoline vapors from escaping and to prevent water, dust and debris from entering the tank.

Monitor Probe and Monitoring Well-Caps

Monitoring Probe Caps are installed on tank riser pipes to help prevent vapors from escaping or water from entering the tank. Monitoring Probe Caps include a wire-grommet fitting to accommodate the electric tank-gauge probe. Lockable Monitoring Well-Caps are installed on slotted PVC-pipe monitoring-wells to help prevent contamination from surface-water intrusion or inadvertent fuel deliveries.

OPW Adaptor & Cap-Height Profiles

The adaptor and cap dimensions below reflect the overall height and installed height of OPW adaptors and adaptor and cap combinations. The installed height is from the gasket seal to the top of the component. For example, the 61VSA height is 6 1/2", but only adds 4-7/8" to the overall height when added to the riser.



61VSA Vapor Recovery Swivel Adaptors

Overall Height Installed Height
6-1/2" 4-7/8"



1611AV Standard Vapor Adaptors

Overall Height Installed Height
5-7/16" 4-3/4"



61SALP Fill Swivel Adaptor

Overall Height Installed Height
4-3/8" 2-7/8"



633T Standard Fill Adaptor

Overall Height Installed Height
3" 2"

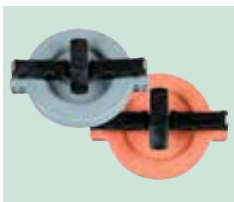

634TT Fill and 1711T Vapor Caps

Overall Height Installed Height
2-9/16" 1-1/2"

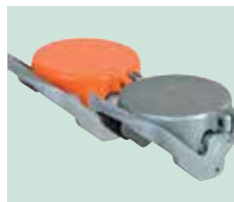

634LPC Fill and 1711LPC Low-Profile Caps

Overall Height Installed Height
7/8" 1/2"

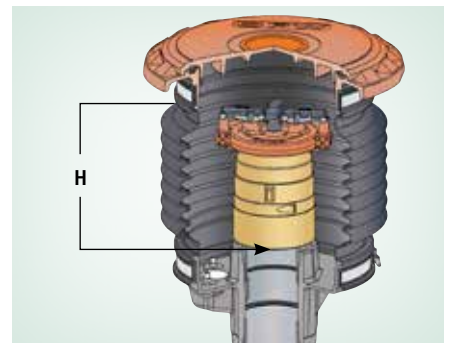

Dimensions

Product Combinations	H = Total Installed Height	
	in	mm
61VSA & 1711T	6 ³ / ₈	162
61VSA & 1711LPC	5 ³ / ₈	137
1611AV & 1711T	6 ¹ / ₄	159
1611AV & 1711LPC	5 ³ / ₈	137
61SALP & 634TT	4 ³ / ₈	111
61SALP & 634LPC	4 ⁷ / ₈	124
633T & 634TT	4 ¹ / ₂	114
633T & 634LPC	3 ¹ / ₂	89

OPW Tight-Fill Top-Seal Adaptors

Tight-Fill Top-Seal Adaptors are installed in spill-containment manholes on the fill riser pipe from an underground fuel-storage tank. They mate with the gravity-drop delivery elbow on the transport truck.



633T-8076

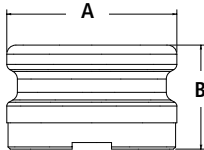

61SALP-1020-EVR



61SALP-MA
E85 EVR Approved

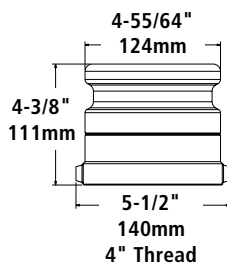

OPW 633T

OPW 633T Top-Seal Adaptors thread onto the fill pipe of underground storage tanks, and are designed to mate with top-seal delivery elbows. Use OPW 634TT, 634TE or 634TTP Top-Seal Caps with 633T Adaptors.

Features

- ◆ **Easy Installation** – integral internal wrenching lugs are provided for installing in the confined space of spill-containers
- ◆ **Accommodate 633LC Lock Clamp** – 4" x 4" 633T (E) models incorporate dual notches in the base to accept 633LC clamps
- ◆ **Manufactured from Durable, Corrosion-Resistant Materials** – bronze and hard-coat aluminum

Ordering Specifications

Product #	Elbow Size	Riser Thread	A		B		Weight		Material
			in.	mm	in.	mm	lbs.	kg	
633T-8060	3"	3"	3 ¹⁹ / ₃₂	93	1 ⁵ / ₈	43	0.96	.44	Bronze
633T-8070*	3"	4"	3 ¹⁹ / ₃₂	93	2 ¹¹ / ₁₆	69	0.71	.32	Hardcoated Al.
633T-8075*	4"	4"	4 ⁵⁵ / ₆₄	124	2 ³¹ / ₃₂	76	0.82	.37	Hardcoated Al.
633T-8076	4"	4"	4 ⁵⁵ / ₆₄	124	2 ³¹ / ₃₂	76	2.70	1.23	Bronze

Note: Maximum height of adaptor is 2¹¹/₁₆" (68mm).

* DEF-compatible

Replacement Parts

Part #	Description
H05289M	Gasket
H09039M	Gasket
H09039M	Gasket
H09039M	Gasket

OPW 61SA Swivel Adaptor

Pressure-decay testing of underground storage tank systems has identified the joint between the tight-fill adaptor and the nipple or tank riser as a persistent leak point. Considerable movement takes place along the hose while the fill elbow is connected. Walk-downs and changes from one compartment to another move the hose across the pavement, rotating the elbow along with it. The result can be a loosening of the adaptor. As the adaptor backs off, the seal between it and the nipple is relaxed and a leak path is created allowing vapors to escape to the atmosphere. Vacuum-assist dispensing systems can aggravate this situation due to the slight pressurization of the UST.

The 61SA Swivel Adaptor mates with 4" top-seal delivery elbows and features a top section that rotates with hose movement while the bottom section remains securely in place maintaining seal integrity.

Features

- ◆ **Dual Seals** – ensure a vapor and liquid-tight seal
- ◆ **Conductive, Self-Lubricating Retaining Rod** – ensures maintenance-free, reliable service life
- ◆ **Same Internal Dimension as Standard 633T Adaptors** – to minimize pressure drop and maximize flow rates for quick product delivery
- ◆ **61SALP-MA – EVR Approved for E85**

Ordering Specifications

Product #	Base Material	Adaptor Material	Weight lbs.	Weight kg
61SALP-1020-EVR*	Bronze	Bronze	7.1	3.2
61SALP-MA	Nickel	Nickel	7.1	3.2
61SA-TOOL**	Wrench		11.0	5.0
H09039M	Replacement Gasket			

*Low-Profile Fill Adaptor **See description on page 104.

Materials

Retaining Ring: Conductive nylon

Set Screws: Stainless-steel

Seals: Buna-N

Listings and Certifications



61SALP-MA are EVR Approved for E85
USA Patent No. 5,664,951



Materials

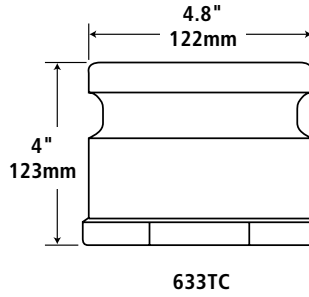

Ordering Specifications

Product #	Elbow Size		Riser Thread		lbs.	kg	Description
	in.	mm	in.	mm			
633TC-8090	4	102	4	102	1.45	.66	Anodized Aluminum
633TCP-3803	4	102	4	102	1.26	.57	Anodized Aluminum

Matching Adaptors & Caps

	Description	Adaptor Part #	Seal	Cap Part #
Fill	3" Fill Elbow	633T, 633TE	Top	634TE
	4" Fill Elbow	633T, 633TE, 61SA, 61SALP	Top	634TT, 634LPC
	4" Coaxial Fill Elbow	633TC, 633TCP	Top	634TT, 634LPC
	3" Fill Elbow	61AS-3"	Side	62
Vapor	4" Fill Elbow	61AS-4"	Side	62, 62TT
	3" Vapor Elbow	1611AV, 1611AVB, 1611VR	Top	1711T, 1711LPC
Monitoring	Monitoring Well Pipe Caps	62M, 116M, 116, 634TTM, 62PMC	Complete Adaptor & Cap Kit	
Loose-Fill	Loose-Fill Pipe Caps 83, 269		Complete Adaptor & Cap Kit	

* Any variation of desired Adaptors will mate with corresponding Caps

OPW Tight-Fill Top-Seal Adaptors

**Coaxial Adaptors
OPW 633TC**

OPW coaxial vapor recovery fittings provide an easy, inexpensive means to convert existing conventional 4" underground storage tank fill pipes to coaxial vapor recovery installations when Stage I Vapor Recovery is required. Normally, little or no digging or breaking of concrete is necessary. Simply remove existing tight-fill adaptor and drop tube (if installation is so equipped), and insert an OPW 61TC Coaxial Drop Tube and the 633TC Adaptor. The OPW 633TC Adaptor is designed to mate with a coaxial delivery elbow.

OPW 633TCP Use On 61SOP

The OPW 633TCP Coaxial Adaptor features a popped vapor-return path that opens only when connected to a fill elbow. When not in use, the vapor path is sealed, preventing fugitive emissions. The 633TCP is a replacement adaptor for the 61TCP Coaxial Drop Tube, and is designed to mate with a coaxial delivery elbow.

NOTE: Poppeted fittings are certified by California Air Resources Board (CARB).

OPW 633LC

OPW 633LC Lock Clamp is designed to lock the OPW adaptor onto the riser pipe, preventing any potential vapor leaks from pressurized systems. The locking clamp slips over the riser pipe. The 633T, 633TE, or 1611 Adaptor is then threaded onto the riser pipe. Next, the lock clamp should be slid up the riser until the protrusions in the lock clamp line up with the notches in the adaptor. Once the adaptor and clamp are engaged, the lock clamp can be tightened and the adaptor will be locked onto the riser pipe, preventing it from being loosened by a delivery elbow.

Additionally, the lock clamp can be turned upside down on the riser pipe to lock the riser into the base of all OPW spill-containers, which have notches in them similar to the adaptors. Using the lock clamp in this manner will lock the riser pipe into the spill-container.

Materials

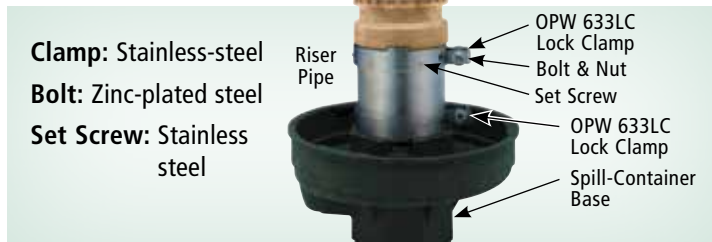

Ordering Specifications

Part #	in.	cm	Description
633LC-1000	4"	10.16	Stainless-Steel Locking Clamp

633TC & 633TCP Instruction Sheet Order Number: **H10013PA**



OPW 61SA-TOOL

The 61SA-TOOL is a wrench designed to thread on the 61SA Fill and 61VSA Vapor Adaptors. The OPW 61SA-TOOL Adaptor installation tool is required to insure proper installation of OPW rotatable swivel adaptors, thread-on spill-containers, fill and vapor adaptors, TC-400 torque cap for pipe nipples and threaded riser adaptors as per EVR requirements. The 61SA-TOOL includes provisions for the use of a torque wrench to facilitate accurate installation and testing.

OPW 634 Series Tight-Fill Top-Seal Caps

Tight-Fill Top-Seal Caps are installed on top-seal adaptors, when not in use, to prevent gasoline vapors from escaping and to prevent water, dust and debris from entering the tank.



EVR Approved for E85

Materials

- Cap & Links: Duratuff®
- Pins: Stainless-steel
- Gasket: Nitrile
- Color: Grey



Ordering Specifications

Product #	in.	mm	lbs.	kg
634TT-7085-EVR	4	102	1.01	.46

Replacement Parts

Part #	Description
H15005M	Nitrile Gasket

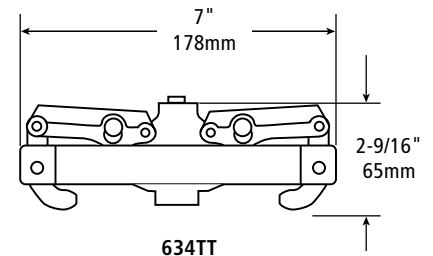

NOTE: Effective height above adaptor: 1-19/32"

OPW 634TT

The OPW 634TT is designed to mate with 4" 633T, 633TE, 61SA, 633TC, and 633TCP Top-Seal Adaptors. Heavy-duty and corrosion-resistant, the body is made of Duratuff® to help eliminate rust and oxidation for a long, maintenance-free life. The toggle lever distributes downward pressure to compress its Buna-N gasket evenly, ensuring a positive, water and vapor-tight seal. The 634TT can be locked with a padlock or wire seal.

The OPW 633TE adaptor is similar to the 633T, except it does not have internal wrenching lugs.

OPW 634TT - Metal

The 634TT-4000 is a metal top-seal cap with the same dimensions as the 634TT-7085.

Materials

- Cap: Die-cast zinc (powder-coated black)
- Lever: Duratuff®
- Pins: Stainless-steel
- Gasket: Nitrile



Ordering Specifications

Product #	in.	mm	lbs.	kg
634TT-4000	4	102	1.01	.46

Replacement Parts

Part #	Description
H15005M	Gasket for 634TT-4000

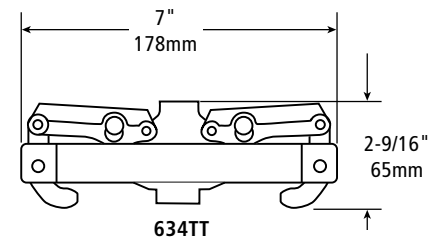

Listings and Certifications



OPW 634TT & 634LPC are EVR Approved for E85



Materials

Cap: Cast zinc alloy
(powder-coated yellow or grey)
Lever: Ductile iron
Gasket: Nitrile



Ordering Specifications

Product #	in.	mm	lbs.	kg
634LPC-0400 - Gray	4	102	3.5	1.59
634LPC-0400D - Yellow	4	102	3.5	1.59

Replacement Parts

Part #	Description
H15005M	Buna-N Gasket

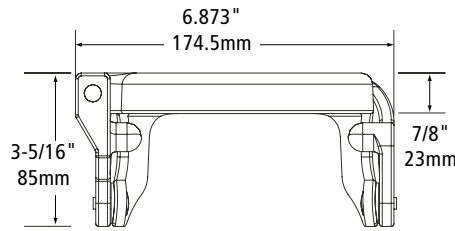

634LPC

Note: Effective height above adaptor: 1/2"

OPW 634LPC Low-Profile Top-Seal Fill Cap

The OPW 634LPC Low-Profile Top-Seal Fill Cap is designed for tight installations where the clearance between the top of the fill adaptor and the underside of the spill-container cover is limited. The rugged iron lever provides a positive cam-action that seats the cap firmly in the adaptor groove for a water and vapor-tight seal. When engaged, the lockable cap adds only 1/2" to the final height of the adaptor. The 634LPC can be used with the 4" OPW 633T, 633TE, 633TC, and 61SA series top-seal fill adaptors.



EVR Approved for E85

Materials

Cap: Duratuff®
Lever: Brass
Gasket: Nitrile
Pivot pin: Stainless-steel
Color: Grey



Ordering Specifications

Product #	in.	mm	lbs.	kg
634TE-7085	3	76	1.11	.50

Replacement Parts

Part #	Description
C01094RB	Lever
H10765M	Gasket
H10731RE	Pivot Pin

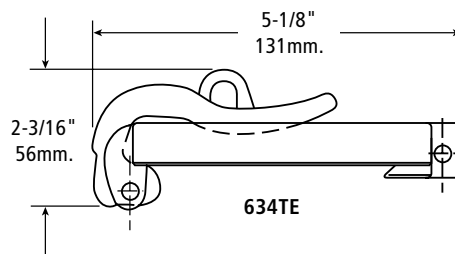

634TE

OPW 634TE Single Lever-Action Top-Seal Cap

The OPW 634TE is a Single Lever-Action Top-Seal Cap designed to mate with 3" OPW 633T Top-Seal Adaptors.

The locking lever seats in the groove in the adaptor, providing a cam-down action on the cap for a positive water and vapor-tight seal. The 634TE can be locked with a padlock or wire seal. Patent #3,118,561.

OPW Tight-Fill Side-Seal Adaptors

OPW 61AS Side-Seal Adaptors thread onto the fill pipe of underground storage tanks, and are designed to mate with side-seal delivery elbows.

Materials

Body: Bronze
Gasket: Nitrile



61AS

Ordering Specifications

Part #	Elbow Size		Riser Thread		lbs.	kg
	in.	mm	in.	mm		
61AS-2477	4	102	4	102	1.99	.90

NOTE: Maximum height of adaptor is 2" (51 mm).

Replacement Parts

Part #	Size		Description
	in.	mm	
H04145M	3 x 3	76 x 76	Gasket
H09039M	4 x 4	102 x 102	Gasket

OPW Tight-Fill Side-Seal Caps

Tight-Fill Side-Seal Caps are installed on side-seal adaptors, when not in use, to prevent gasoline vapors from escaping and to prevent water, dust and debris from entering the tank.

OPW 62TT

The OPW 62TT Side-Seal Cap is designed to mate with the 61AS Side-Seal Adaptor. The cap has a lever and gasoline-resistant Buna-N gasket to help assure a positive seal. The 62TT is constructed of Duratuff®, a high-impact composite that helps eliminate rust and oxidation to assure a long, maintenance-free life.

Materials

Cap & Links: Duratuff®
Pins: Stainless-steel
Color: Black



62TT

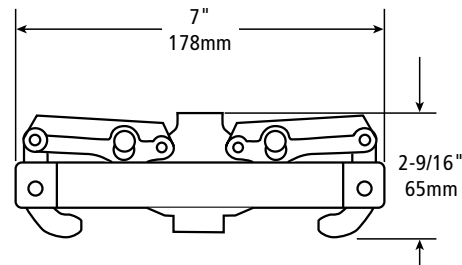

Ordering Specifications

Product #	in.	mm	lb.	kg
62TT-7085	4	102	1.15	.52

Replacement Parts

Part #	Description
C03485M	Gasket

Materials

Adaptor: Bronze
Base: Bronze
Retaining Ring: Conductive nylon
Set Screws: Stainless-steel
Seals: Nitrile



61VSA-1020-EVR
 USA Patent No. 5,664,951

Features

- ◆ **Dual Seals** – ensure a vapor and liquid-tight seal
- ◆ **Conductive, Self-Lubricating Retaining Rod** – ensures maintenance-free, reliable service life
- ◆ **Same Internal Dimension as Standard 633T Adaptors** – to minimize pressure drop and maximize flow rates for quick product delivery
- ◆ **Self Guiding Poppet** – for consistent tight seal

Ordering Specifications

Product #	Base Material	Adaptor Material	Weight	
			lbs.	kg
61VSA-1020-EVR	Bronze	Bronze	10.5	4.8
61SA-TOOL	Wrench		11.0	5.0
H09039M	Replacement Gasket			

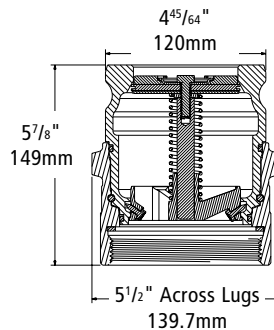

OPW Stage I Vapor Recovery Adaptors and Caps

Stage I Vapor Recovery Adaptors are installed in spill-containment manholes on the vapor recovery riser pipe from an underground gasoline-storage tank. They mate with the vapor recovery elbow on the delivery transport truck when recovery of gasoline vapors is required.

OPW 61VSA Vapor Swivel Adaptor

The OPW 61VSA Vapor Swivel Adaptor is a poppeted adaptor, designed to mate with a vapor recovery elbow, featuring a top section that rotates with hose movement while the bottom section remains securely sealed to the 4-inch tank riser.



61SA-TOOL

OPW 61VSA-MA Vapor Recovery Swivel Adaptor

Materials

Adaptor: Nickel-coated brass
Base: Nickel-coated brass
E85 EVR Approved

Ordering Specifications

Product #	Base Material	Adaptor Material	Weight	
			lbs.	kg
61VSA-MA	Nickel Coated Brass	Nickel Coated Brass	10.5	4.8
H09039M	Replacement Gasket			



OPW 61SA-TOOL

The 61SA-TOOL is a wrench designed to thread on the 61SA Fill and 61VSA Vapor Adaptors. The OPW 61SA-TOOL Adaptor installation tool is required to insure proper installation of OPW rotatable swivel adaptors, thread-on spill-containers, fill and vapor adaptors, TC-400 torque cap for pipe nipples and threaded riser adaptors as per EVR requirements. The 61SA-TOOL includes provisions for the use of a torque wrench to facilitate accurate installation and testing.

Listings and Certifications



OPW 61VSA Series Adaptors are EVR Approved for E85



OPW 1611 Series Vapor Recovery Adaptor

The OPW 1611AV and 1611AVB are popped adaptors, designed to mate with a vapor recovery elbow, for returning gasoline vapor to the tank truck during a fuel delivery to an underground tank.

Materials

- Body:** Clear anodized aluminum or cast bronze
- Stem:** Chrome-plated steel
- Stem Guide:** Acetal resin
- Spring:** Stainless-steel
- Gasket:** Nitrile



1611AV 3" x 4"
(76 x 102mm)

Ordering Specifications

Product #	Elbow Size		Riser Thread		Weight		Body Material
	in.	mm	in.	mm	lbs.	kg	
1611AV-1605	3	76	3	76	2.91	1.32	Clear Anodized Aluminum
1611AV-1620	3	76	4	102	3.25	1.48	Clear Anodized Aluminum
1611AVB-1625	3	76	4	102	7.97	3.62	Cast Bronze

Replacement Parts

Key	Part #	Description
1	C02642M	Bridge Guide
Not Shown	H15294M	Screw (3") (76mm)
2	H04145M	Gasket (3") (76mm)
	H04150M	Gasket (3" x 4") (76 x 102mm)
3	H08989M	Spring
61VSA-KIT Complete Replacement Kit		

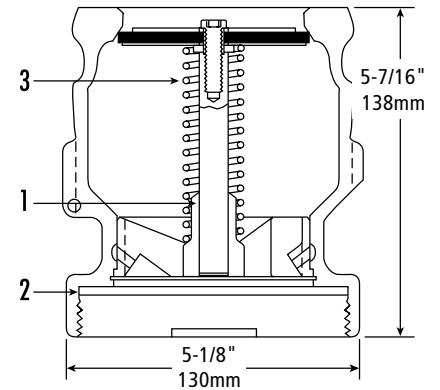

Materials

Body: Duratuff®
Pins: Stainless-steel
Links: Duratuff®
Gasket: Nitrile
Color: Orange

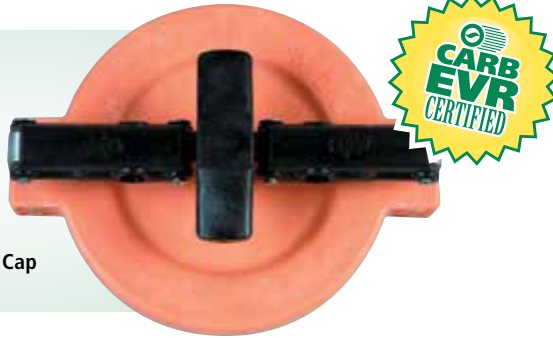

1711T Cap

Ordering Specifications

Product #	in.	mm	lbs.	kg
1711T-7085-EVR	3	76	1.1	.50

Replacement Parts

Part #	Description
H10886M	Nitrile Gasket

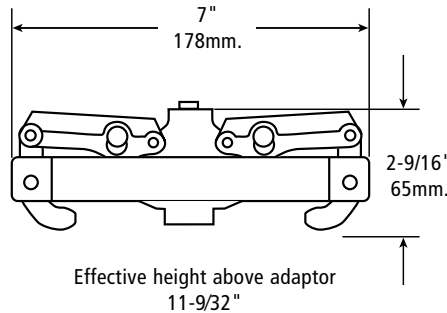

OPW Stage I Vapor Recovery Caps
OPW 1711T

The OPW 1711T Vapor Recovery Cap is for use with the OPW 1611AV, 61VSA, 1611AVB and 1611VR Adaptors. The 1711T is installed on the vapor recovery adaptor, when not in use, to prevent vapors from escaping and to prevent water, dust and debris from entering the tank. Constructed of Duratuff® to help prevent corrosion, the OPW 1711T will couple to Civacon/OPW 4" Kamloks, and features a center post that allows an even distribution of force when coupling to the adaptor. The 1711T can be locked with a padlock.

Materials

Cap: Cast zinc alloy (powder-coated orange)
Lever: Ductile iron
Gasket: Nitrile



1711LPC Cap

Effective height above adaptor 1/2"

Ordering Specifications

Product #	in.	mm	lbs.	kg
1711LPC-0300	3	76	3.5	1.59

Replacement Parts

Part #	Description
H15005M	Nitrile Gasket

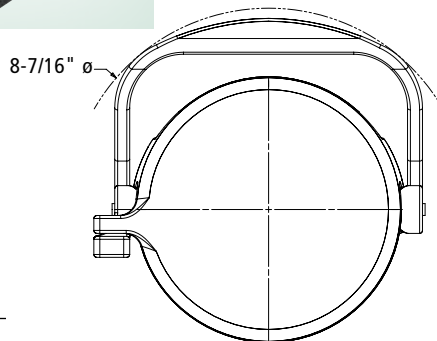

OPW 1711LPC Low-Profile Vapor Cap

The OPW 1711LPC Low-Profile Top-Seal Vapor Cap is designed for tight installations where the clearance between the top of the vapor adaptor and the underside of the spill-container or manhole cover is limited. The rugged iron lever provides a positive cam-action that seats the cap firmly in the adaptor groove for a water and vapor-tight seal. When engaged, the lockable cap adds only 1/2" to the final height of the adaptor. The cap is powder-coated API Orange to signify vapor recovery. The 1711LPC can be used with the OPW 3" 1611AV, 1611AVB and 61VSA series vapor adaptors.

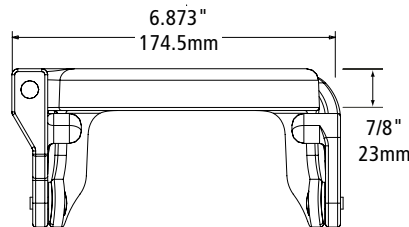
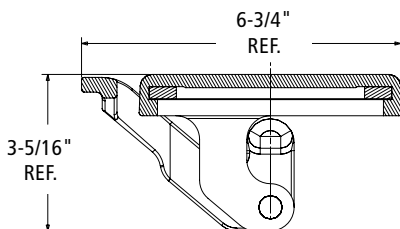

Listings and Certifications



OPW 1711 Series Caps are EVR Approved for E85



OPW Monitoring Well/Pipe/Probe Caps

Monitoring Probe Caps are installed on tank riser pipes to help prevent vapors from escaping or water from entering the tank. Monitoring Probe Caps include a wire-grommet fitting to accommodate the electronic tank-gauge probe.

OPW 62M Monitor Probe Cap & Adaptor Kit

The 62M Monitoring Probe & Adaptor Kit includes a 4" side-sealing adaptor, 4" side-sealing cap (tapped), and a 3/8" or 1/2" wire-grommet to secure the cable from an electronic tank-gauge probe in the tank riser pipe. A bracket, located on the underside of the cap, is provided to install a tension wire to relieve strain on probe cables. The 62M is gasketed to seal against water and debris entering, or vapors from escaping the tank. The cap includes provisions for a padlock to secure entry.

62M Monitor Probe Cap

- Body: Cast aluminum
- Cap: Cast aluminum
- Seals: Nitrile
- Latch: Duratuff®

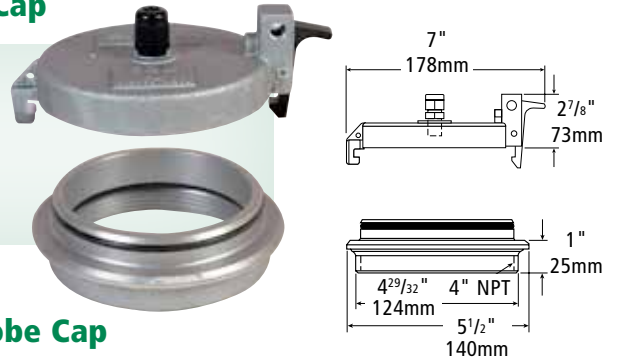

62M-MA Monitor Probe Cap

- Body: Anodized aluminum
- Cap: Anodized aluminum
- E85 EVR Approved



Ordering Specifications

Product #	Body	Cap	Grommet		Riser Thread		lbs.	kg	
			in.	mm	in.	mm			
62M-0375	Alum.	Alum.	3/8	9.5	4	102	1.3	.59	Accepts .069" - .178" diameter wire
62M-0500	Alum.	Alum.	1/2	13	4	102	1.3	.59	Accepts .170" - .470" diameter wire
62M-MA	Nickel	Nickel	3/8	9.5	4	102	1.3	.59	Accepts .170" - .470" diameter wire
201478	Alum.	Alum.	N/A	N/A	4	102	1.3	.59	No Grommet
H09039M	Replacement Gasket								

OPW 116M

The OPW 116M Monitor Probe Cap is a standard 116 4" threaded pipe cap, drilled and tapped to accept a 3/8" or 1/2" wire-grommet to secure an electronic tank-gauge probe in a tank riser pipe. The 116M is gasketed for vapor and watertight service.

OPW 116

The OPW 116 Pipe Cap threads onto 4" riser pipes and provides access to ball-float extractor fittings and underground storage tank-bung openings. The 116 is constructed of composite Duratuff® to prevent rusting or corroding of steel riser pipes.

Materials

- OPW 116M
- Body: 4" Duratuff®
- Cross bar: Zinc-plated steel



116M Cap

- OPW 116
- Body: 4" Duratuff®
- Seal: Nitrile



116-7085

Ordering Specifications

OPW 116M

Product #	Description	Riser Thread	lbs.	kg
116M-0375	3/8" Grommet	4" (102mm)	.45	.2
	Accepts .069" - .178" diameter wire			
116M-0500	1/2" Grommet	4" (102mm)	.45	.2
	Accepts .170" - .470" diameter wire			
H11199M	Replacement Gasket			

OPW 116

116-7085			.40	.18
----------	--	--	-----	-----

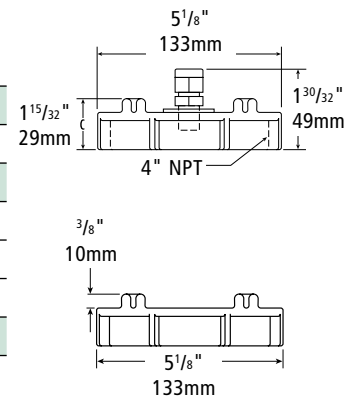

62M Series Instruction Sheet Order Number: H14491PA

Materials

Cap: Duratuff®
 Adaptor Ring:
 Cast aluminum



634TTM

Ordering Specifications

Product #	lbs.	kg
634TTM-7087	1.42	.65

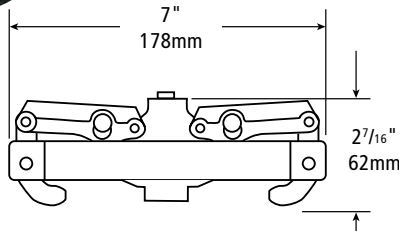

**OPW Monitoring Well/
 Pipe Caps**

**OPW 634TTM Well
 Cap Kit**

The OPW 634TTM Well-Cap Kit is designed to install onto a 4" slotted PVC monitoring-well. The cap is marked "Do Not Fill" to clearly identify the monitoring-well. A cast-aluminum adaptor ring is set-screwed to the top of the slotted PVC well, and the cap mates with the ring. The 634TTM can be locked with a padlock or a wire seal.



62PMC

Ordering Specifications

Product #	Description	lbs.	kg
62PMC-0400	Monitoring Cap	1.3	.59

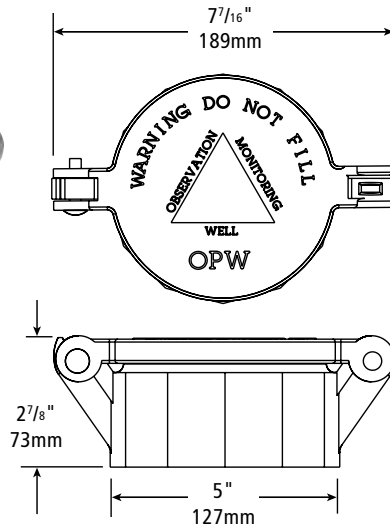

**OPW 62PMC Lockable
 Monitoring Cap**

The OPW 62PMC is designed to thread or solvent-weld to a 61SPVC 4" slotted PVC monitoring-well pipe. The 62PMC is constructed of durable PVC with a stainless-steel hinge pin for resistance to rust and corrosion. An API warning statement, "Monitoring-Well...Do Not Fill," is permanently molded into the cap. The 62PMC can be locked with a long-shank padlock.



61SPVC

Ordering Specifications

Product #	Description	Length		Slotted Section		Weight	
		ft.	m	ft.	m	lbs.	kg
61SPVC-4000	4" x 13' Slotted PVC Pipe	13	3.96	10	3.04	26.5	12.0
61SPVC-4015	4" x 15' Slotted PVC Pipe	15	4.57	12	3.65	30.5	13.8
61SPVC-4020*	4" x 20' Slotted PVC Pipe	20	6.09	18	5.48	41.0	18.6

*20 ft. Models come in two (2) 10 ft. pieces.

**OPW 61SPVC Slotted
 PVC Pipe**

The OPW 61SPVC Slotted PVC Pipe is designed for monitoring-well applications. The 61SPVC is constructed of durable Schedule 40 PVC pipe, PVC bottom plug with slot thickness of .020".

634TTM-7087 Instruction Sheet Order Number: **H10772PA**

OPW Loose-Fill Pipe Cap Assemblies

Loose-Fill Pipe Cap Assemblies are installed in spill-containment manholes on fill riser pipes from an underground fuel-storage tank. They are used when a tight-fill connection is not required.

OPW 83

The OPW 83 Fill Cap Assembly threads onto the fillpipe of an underground or aboveground tank. The screw-on cap is gasketed to ensure a tight seal against air, water, dust and debris. The 83 can be locked with a padlock or wire seal.

Materials

Body: ZA alloy
Cap: Cast iron
Gasket: Nitrile



83 Fill Cap

Ordering Specifications

Product #	Riser Thread			
	in.	mm	lbs.	kg
83-0022	2	51	2.46	1.12

Replacement Parts

Part #	in.	mm	Description
H04898M	2	51	Cap
H01608M	2	51	Gasket

Dimensions

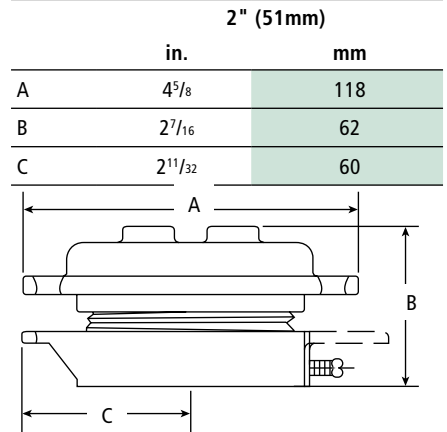

OPW 269 Sanitary Tank Hatch

The OPW 269 Sanitary Tank Hatch threads onto the fill pipe of an underground sanitary waste-disposal tank. The 269 is foot-operated and quick-opening/closing for clean emptying of sanitary waste from RVs, campers and travel trailers. The non-recessed design provides straight-through flow to eliminate entrapment of waste materials.

Materials

Body: Coated ductile iron
Cap: Zinc



Ordering Specifications

Product #	Riser Thread			
	in.	mm	lbs.	kg
269-0085	4	102	10.92	4.91

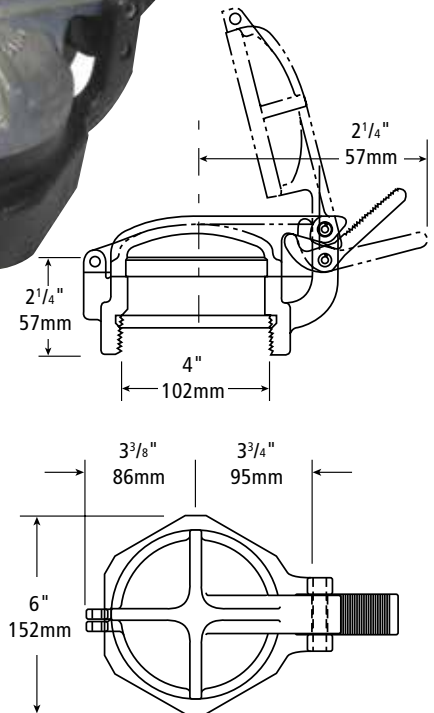

Testable 7150 Overfill-Prevention Valve

Patent-Pending



**Testing & Verification
Easy as 1·2·3**

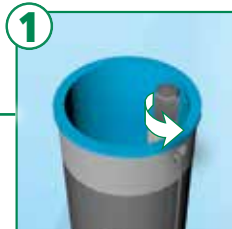
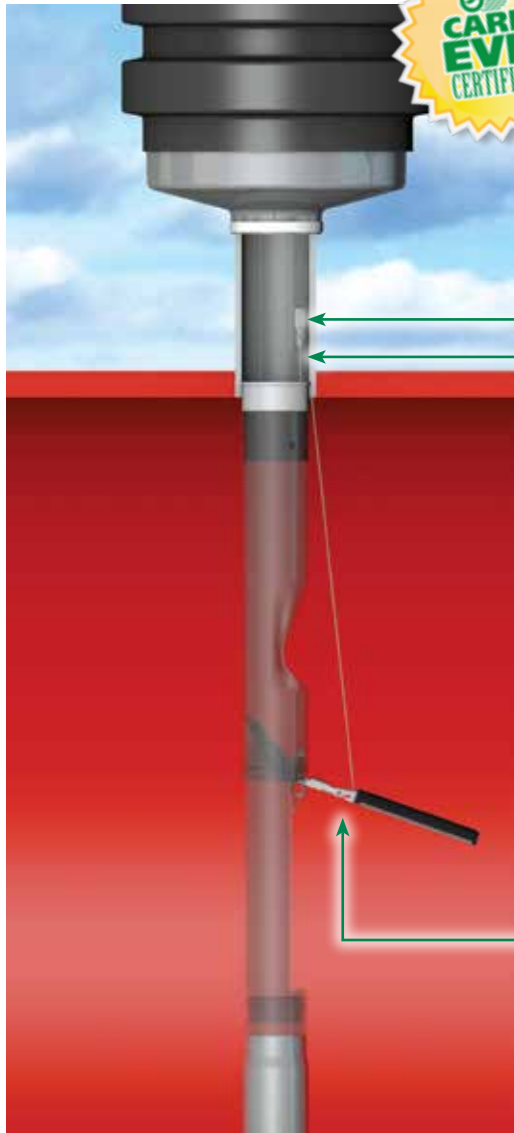

Loosen test plug

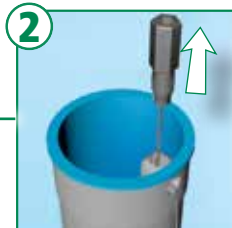

Lift float with cable to simulate fill

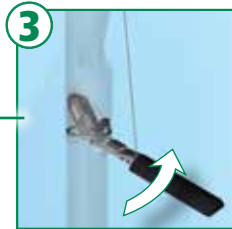

Validate proper poppet operation

The OPW Testable 7150 helps you be in compliance with the NEW EPA Regulations

- ◆ The Only UST Overfill-Prevention Valve that is testable without removal from the tank
- ◆ A testable feature is attached to a sealed plug in the inlet Adaptor
- ◆ The plug is easily accessed with a standard socket extension
- ◆ Attached to the extension, the testable feature can be raised and lowered, allowing the user to inspect the valve operation from the inside of the tube
- ◆ The plug is then easily reinstalled to the inlet Adaptor from grade
- ◆ No fill components, overfill valves, or vapor-tight seals have to be removed - avoids compromising vapor-tight compliance
- ◆ The Testable 7150 uses the same industry leading overfill-prevention technology for strong vapor-tight compliance
- ◆ B100 Compatible (ULC)

NOTE: The OPW 7150 is designed for use on tight-fill gravity-drop applications only. Do not use for pressure-fill applications.

Ordering Specifications

Product #	Description	A- Upper Tube Length		B- Lower Tube Length		C- Overall Length		Max. Riser Length		Max. Nominal Tank Dia.		Max. Actual Tank Dia.		Weight	
		in.	m	in.	m	in.	m	in.	m	in.	m	in.	m	lbs.	kg
7150-400CT*	Testable Vapor-Tight Overfill Valve, 5 Ft. Bury, 8 Foot Tank	60	1.5	83	2.1	154 ³ / ₄	3.9	53 ¹ / ₂	1.4	96	2.4	107	2.7	16	7
7150-410CT*	Testable Vapor-Tight Overfill Valve, 10 Ft. Bury, 10 Foot Tank	120	3.1	102	2.6	234 ³ / ₄	5.9	113 ¹ / ₂	2.9	120	3.1	126	3.2	25	11
7150-420CT*	Testable Vapor-Tight Overfill Valve, 10 Ft. Bury, 12 Foot Tank	120	3.1	126	3.2	258 ³ / ₄	6.5	113 ¹ / ₂	2.9	144	3.7	150	3.8	26	12
206740-KIT	Replacement Cable Kit														
206741	Replacement Inlet Tube w/ 206740 Cable Kit														

* ULC B100 Compatible

Listings and Certifications



Overfill-Prevention and Venting Equipment

7150 Testable Overfill Valve

The OPW Testable 7150-T Overfill-Prevention Valve is the easiest, quickest and most cost-efficient way to ensure that your overfill valves will operate when called upon - verifiable without removing them from the tanks. The OPW 7150-T Testable Overfill-Prevention Valve is the only UST Overfill-Prevention Valve that is testable from the surface without removal from the tank.

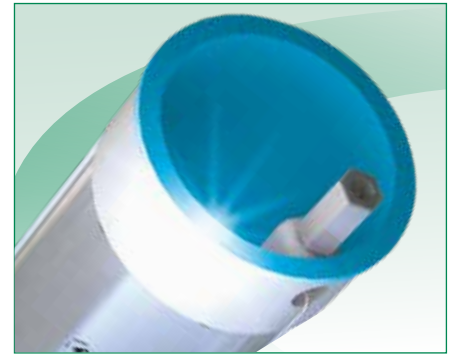

6150 & 7150 Overfill-Prevention Valves

The OPW 6150 and 7150 vapor-tight Overfill-Prevention Valves are two-stage shut-off valves designed to prevent the overfill of underground storage tanks by providing a positive shut-off of product delivery. Models of the 6150 and 7150 are available to meet virtually any UST application, including two-point, coaxial, poppeted coaxial and remote fill. The 7150 vapor-tight model is designed for enhanced vapor recovery (EVR) applications. Both the 6150 and 7150 are designed for use on tight-fill gravity-drop applications only, and can be installed in the fill riser of both new and existing underground storage tanks.

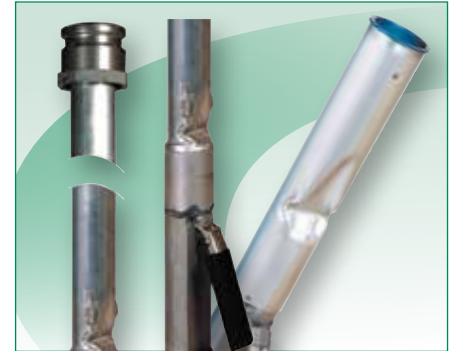

Ball-Float Vent Valves and Extractor Fittings

OPW Ball-Float Vent Valves protrude into underground storage tanks from the Stage I vapor-return riser pipe. As the tank becomes full during a product drop, the ball seat restrict the flow of vapors back to the transport truck or through the tank-vent. As the vapors are compressed in the tank, product flow into the tank is severely restricted.

OPW ball-floats are mounted in OPW extractor fittings to maintain access through grade-level manholes.



Drop Tubes and Accessories

OPW drop tubes are installed inside tank fill risers to prevent fuel from contacting riser joints. Drop tubes extend close to the bottom of the tank to minimize turbulence and vapor production. Tank-bottom protectors are installed on the bottom of drop tubes to prevent tank erosion at the fill point.

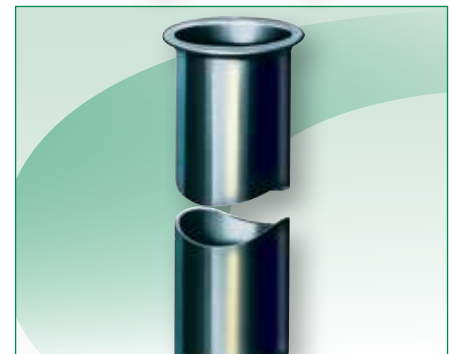

Pressure Vacuum Vents and Adaptors

Pressure Vacuum Vents are installed on the top of vent pipes from underground or aboveground fuel-storage tanks. The vent-cap and internal wire screen are designed to protect the tank-vent lines against intrusion and blockage from water, debris or insects. A normally closed poppet in the valve opens at a predetermined pressure or vacuum setting to allow the tank to vent.



OPW 7150 Overfill-Prevention Valves

The CARB-certified OPW 7150 vapor-tight Overfill-Prevention Valve is designed to prevent the overfill of underground storage tanks by providing a positive shut-off of product delivery. The shut-off valve is an integral part of the drop tube used for gravity filling. The OPW 7150 allows easy installation (without breaking concrete) and requires no special manholes.

The OPW 7150 is a vapor-tight two-stage shut-off valve. When the liquid level rises to about 95% of tank capacity, the valve mechanism is released, closing automatically with the flow. This reduces the flow rate to approximately 5 gpm through a bypass valve. The operator may then stop the filling process and disconnect and drain the delivery hose. As long as the liquid exceeds the 95% level, the valve will close automatically each time delivery is attempted.

If the delivery is not stopped and the liquid rises to about 98% of tank capacity, the bypass valve closes completely. No additional liquid can flow into the tank until the level drops below a reset point.

NOTE: The 7150 Overfill-Prevention Valve can be adjusted to shut off at any desired tank capacity. Please contact the Authority Having Jurisdiction (AHJ) and review local, state and national codes to determine the regulatory requirements governing shut-off capacity in your region, as well as take into account other considerations such as extreme tank tilt. In all cases, the upper tube must protrude into the tank at least 6 1/2" to ensure that the valve can shut off flow into the tank completely before the top of the tank is wetted as per EPA requirements.

7150 Instruction Sheet Order Number: **H15524PA**

Materials

- Valve Body:** Cast aluminum
- Float:** Nitrile rubber, closed-cell foam
- Valve:** Aluminum
- Seals:** Viton®
- Upper & lower Drop Tube:** Aluminum
- Plastic parts:** Acetal
- Hardware:** Stainless-steel

Features

- ◆ **Simple, Easy and Quick Installation** – no excavation or special manholes required.
- ◆ **Economical** – costs a fraction of expensive, complicated and difficult-to-install valves.
- ◆ **Furnished Complete** – supplied with new upper and lower drop tubes, mounting hardware and thorough instructions for quick job-site time.
- ◆ **Completely Automatic Operation** – no pre-checks to perform, no resets and no overrides to be broken or abused.
- ◆ **No Pressurization of the Tank** – operates directly from liquid level.
- ◆ **Will Accept a Dipstick for Gauging**
- ◆ **Retrofits Directly** – for both new and existing tanks with 4" fill risers.
- ◆ **Quick Drain Feature** – automatically drains hose when head pressure is relieved.
- ◆ **Best Flow Rate in The Industry***

* OPW Test Lab results



Important

In order to prevent product spillage from the Underground Storage Tank (UST), properly maintained delivery equipment and a proper connection at the tight-fill adaptor are essential. Delivery personnel should be managed and trained to inspect delivery elbows and hoses for damaged and missing parts. They should always make certain there is a positive connection between the adaptor and elbow. If delivery equipment is not properly maintained, or the elbow is not securely coupled to the adaptor, a serious spill may result when the OPW 7150 closes, causing a hazard and environmental contamination.

NOTE: The OPW 7150 is designed for use on tight-fill gravity-drop applications only. Do not use for pressure-fill applications.

Advantages of Overfill-Prevention Compared to Overfill-Warning Systems:

- ◆ **Completely Automatic Operation** – does not rely on the alertness or speed of response of the delivery attendant for certainty of overfill-prevention.
- ◆ **Keeps the Top of UST "Dry," per EPA Requirements** – eliminating possible leaks at loose bung fittings and the need for double containment on vent lines.
- ◆ **Does Not Rely on Pressure in the UST to Stop Flow** – allowing faster fill times and reducing spill risk.
- ◆ **Speeds Delivery Operations** – product flows unimpeded into the tank until the hose "kick" that accompanies the valve shut-off provides a clear signal that the liquid has reached the shut-off level.
- ◆ **Simple and Inexpensive Installation** – in both two-point and coaxial-fill applications, no additional excavation, manholes or vent piping are required.

Listings and Certifications



OPW 7150M is EVR Approved for E85

Raising The Standard In Overfill-Prevention

From the company that brought you the industry standard OPW 6150, OPW raises the standard with the introduction of the **7150 Overfill-Prevention Valve** – breakthrough innovation that takes overfill-prevention to a whole new level of overfill perfection.

- Eliminates curing issues due to hot or cold temperatures
- Easier, quicker installation
- Higher quality more reliable installation
- Lower costs
- Greater protection against fugitive emissions and pressure decay
- Fastest flow rate in the industry

The new 7150 is a two-stage, positive shut-off valve, providing completely automatic operation with no pre-checks to perform, no resets, and no overrides to be broken or abused. The valve closes when the tank level rises to 95% capacity and provides a special bypass valve so the tank can be filled to a maximum capacity of 98%. The 7150 is available for direct-bury and remote applications.



All Vapor-Tight Overfill Valves are CARB EVR Certified

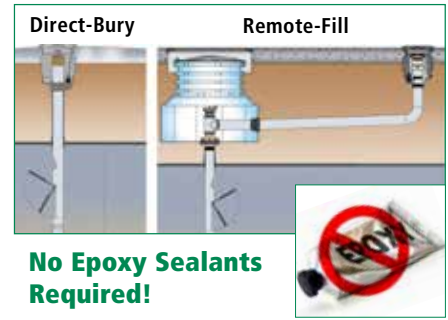

Replacement Parts

Part #	Description
6150K-0001	Replacement Float Kit
H11931M	Drop Tube Seal
H14840M	Lower Tube Seal
C05117	Lower Tube
C03899M	Non-Vapor-Tight Inlet Tube
D02508	Vapor-Tight Inlet Tube (Blue)
7150-INLET	7150 Inlet Adaptor
7150CB-INLET	7150 Biodiesel Inlet Adaptor
7150M-INLET	7150 Methanol/Ethanol Inlet Adaptor
7150T-INLET	7150 Testable Inlet Adaptor

7150 Ordering Specifications

Product #	Description	Bury Depth		Tank Diameter		Upper Tube Length		Lower Tube Length		Overall Length		Max. Riser Length		Max. Nominal Tank Dia.		Max. Actual Tank Dia.		Weight	
		ft.	m	ft.	m	in.	m	in.	m	in.	m	in.	m	in.	m	in.	m	lbs.	kg
7150-400CB*	B20-B100 Overfill Valve	5	1.5	8	2.4	60	1.5	83	2.1	155 ³ / ₄	3.9	53 ¹ / ₂	1.4	96	2.4	107	2.7	16	7
7150-410CB*	B20-B100 Overfill Valve	10	3.0	10	3.0	120	3.1	102	2.6	234 ³ / ₄	5.9	113 ¹ / ₂	2.9	120	3.1	126	3.2	25	11
7150-420CB*	B20-B100 Overfill Valve	10	3.0	12	3.6	120	3.1	126	3.2	258 ³ / ₄	6.5	113 ¹ / ₂	2.9	144	3.7	150	3.8	26	12
7150-400C	Vapor-Tight Overfill Valve	5	1.5	8	2.4	60	1.5	83	2.1	155 ³ / ₄	3.9	53 ¹ / ₂	1.4	96	2.4	107	2.7	16	7
7150-410C	Vapor-Tight Overfill Valve	10	3.0	10	3.0	120	3.1	102	2.6	234 ³ / ₄	5.9	113 ¹ / ₂	2.9	120	3.1	126	3.2	25	11
7150-420C	Vapor-Tight Overfill Valve	10	3.0	12	3.6	120	3.1	126	3.2	258 ³ / ₄	6.5	113 ¹ / ₂	2.9	144	3.7	150	3.8	26	12
7150-4000	Non Vapor-tight Overfill Valve	5	1.5	8	2.4	60	1.5	83	2.1	155 ³ / ₄	3.9	53 ¹ / ₂	1.4	96	2.4	107	2.7	16	7
7150-4010	Non Vapor-tight Overfill Valve	10	3.0	10	3.0	120	3.1	102	2.6	234 ³ / ₄	5.9	113 ¹ / ₂	2.9	120	3.1	126	3.2	25	11
7150M-412C	E85 Vapor-tight Overfill Valve	10	3.0	10	3.0	120	3.1	102	2.6	234 ³ / ₄	5.9	113 ¹ / ₂	2.9	120	3.1	126	3.2	38	17.3
7150-TOOLCT	7150 Installation Tool																	2.5	1
61JSK-4RMT	Jack Screw Kit For Vapor-Tight Remote Applications																	1.5	0.7
61JSK-4410	Jack Screw Kit For Composite Base Spill Bucketst																	1	0.5
61JSK-44CB	Jack Screw Kit For Cast-Iron Base Spill Buckets																	1	0.5
71JSK-4RMT	E85 Jack Screw for Remote-Fill Applications																	1	0.5
71JSK-44MA	E85 Jack Screw for Direct-Fill Applications																	1.5	0.7

61JSK-4410 AND 61JSK-44CB Instruction Sheet Order Number: H15289M

*ULC B100 Compatible

7150 Vapor-Tight Remote Fill

The OPW Vapor-Tight Remote Fill is designed for two-point vapor-tight remote-fill applications, where the fill point is not directly over the UST. A CARB-approved vapor-tight 7150 overfill valve is installed in the sump through a riser pipe directly over the tank.

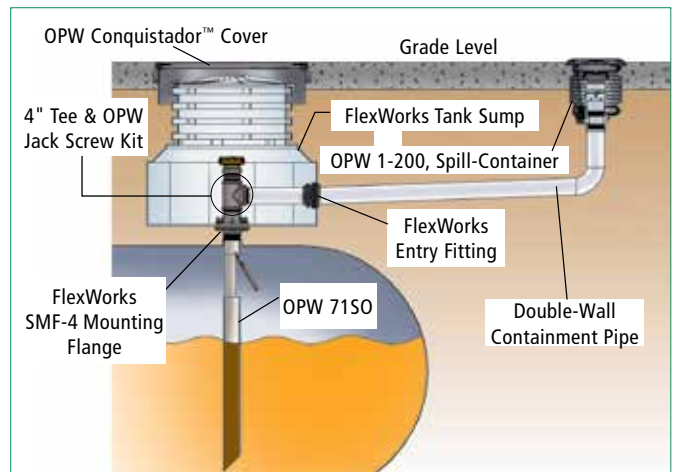
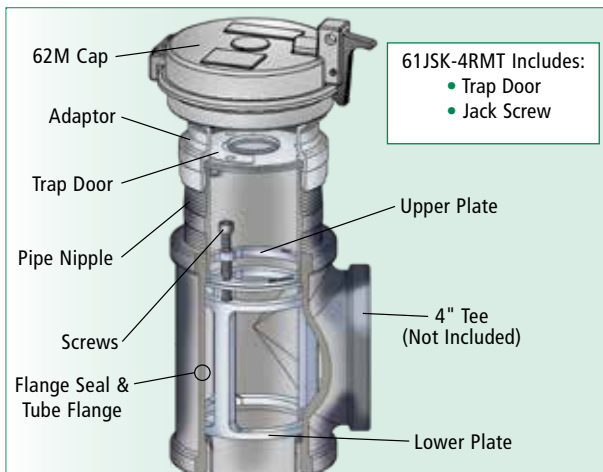

61SOR Remote-Fill

The OPW 61SOR is designed for two-point remote-fill applications, where the fill point is not directly over the UST. The valve is installed in the tank through a riser pipe directly over the tank. A window in the drop tube is aligned with the entrance of the fill pipe from the remote-fill location to allow product to flow into the drop tube and down through the valve. A riser seal prevents product from flowing into the tank from outside the drop tube. A "trap door" assembly installed in the riser above the tank provides access for a gauging stick. Trap door, adaptor and cap are included with 61SOR.

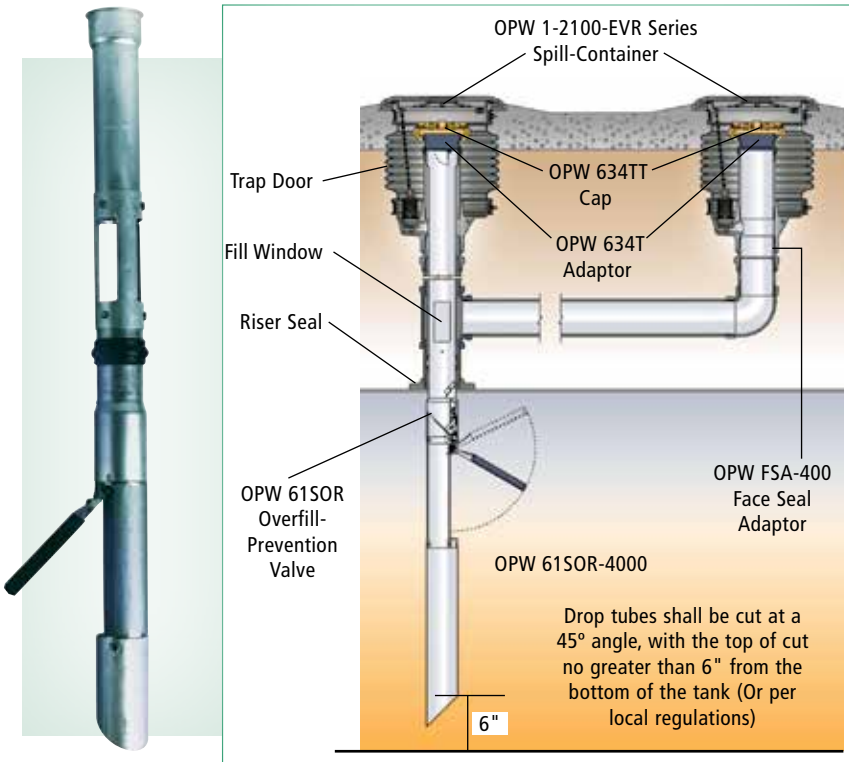

61SOC Coaxial

The OPW 61SOC is used for coaxial-fill applications, tanks equipped with a single product/vapor-return connection. The 61SOC replaces the standard coaxial-fill drop tube in a 4" riser fill pipe.

61SO-4000 Series Instruction Sheet Order Number: **H11764M**

61SOC Coaxial Fill Tube Instruction Sheet Order Number: **C03634PA**

61SOR Remote Fill Tube Instruction Sheet Order Number: **H11964M**

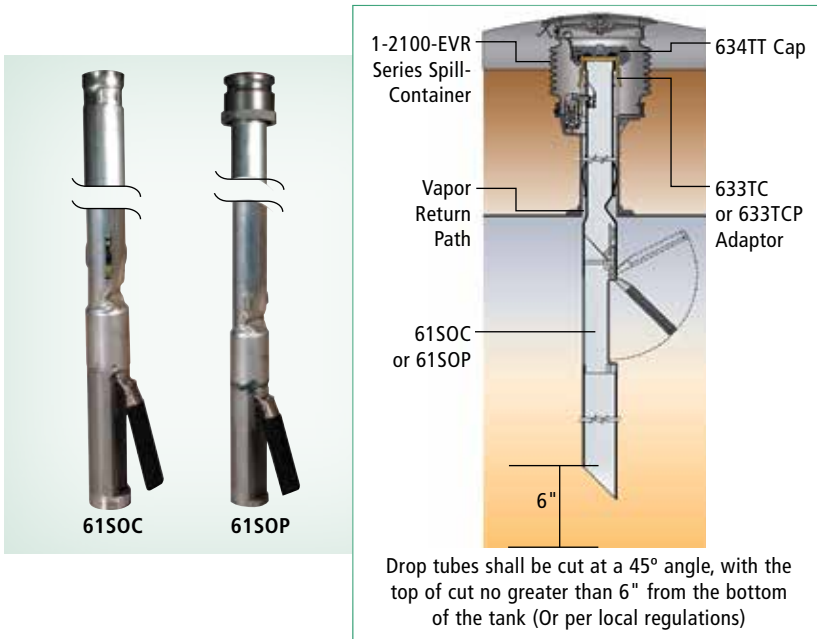

Typical Application Assembly

Installation schematic typical; exact dimensions will vary with tank configuration.

* From inside wall of tank to bottom of upper tube

61SOK Float Kit Instruction Sheet Order Number: **H11403PA**

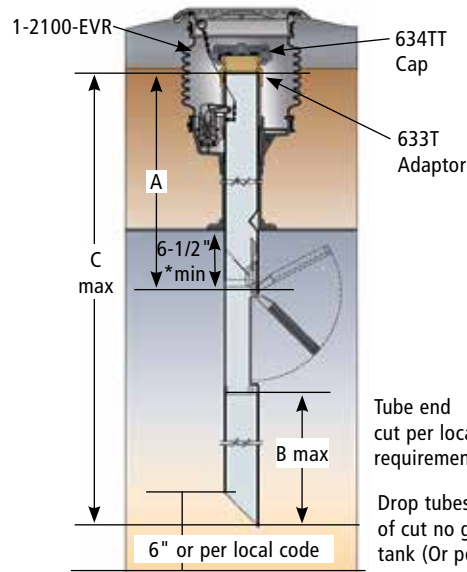

Replacement Parts

Part #	Description
61SOK-0001	Float Kit
C03899M	Two-Point Inlet Tube
C03632M	Coaxial Inlet Tube
D01756	Inlet Tube/Adaptor Assy. for 61SOP
H11931M	Drop Tube O-Ring
C03749	Trap Door Assy. (Remote)

Tube end cut per local requirements

Drop tubes shall be cut at a 45° angle, with the top of cut no greater than 6" from the bottom of the tank (Or per local regulations)

Ordering Specifications

Product/ Suffix #	Description	A-Upper Tube Length		B-Lower Tube Length		C-Overall Length		Max. Riser Length		Max. Nominal Tank Dia.		Max. Actual Tank Dia.		Weight	
		in.	m	in.	m	in.	m	in.	m	in.	m	in.	m	lbs.	kg
61SOC-4001	Coaxial	60	1.5	83	2.1	154 ³ / ₈	3.9	53 ¹ / ₂	1.4	96	2.4	107	2.7	16	7
61SOC-4011	Coaxial	120	3.1	102	2.6	233 ³ / ₈	5.9	113 ¹ / ₂	2.9	120	3.1	126	3.2	25	11
61SOP-4002	CARB, pop. coaxial	60	1.5	83	2.1	154 ³ / ₈	3.9	53 ¹ / ₂	1.4	96	2.4	107	2.7	20	9
61SOP-4012	CARB, pop. coaxial	108	2.7	102	2.6	221 ³ / ₈	5.6	101 ¹ / ₂	2.6	120	3.1	126	3.2	27	12
61SOR-4000*	Remote (non-vapor-tight, 8 ft tank diameter max)	72	1.8	83	2.1	166 ³ / ₈	4.2	65 ¹ / ₂	1.7	96	2.4	107	2.7	19	9
61SOR-400C*	Remote (vapor-tight, 8 ft tank diameter max)	72	1.8	83	2.1	166 ³ / ₈	4.2	65 ¹ / ₂	1.7	96	2.4	107	2.7	19	9

*Remote-fill applications

Materials

Body: Duragard®
Coated Cast-Iron
Cage Assembly: ZA12 Zinc/Alloy
(TEE)



Features

- ◆ **Duragard®-Coated Cast-Iron Body**
– helps prevent rust and corrosion for long service life
- ◆ **ZA12 Zinc/Alloy Cage Assembly**
– eases installation and removal of ball-float vent valves and test plugs
- ◆ **Precision-Machined Threads** – help prevent cross threading of the ball-float or tank riser pipe
- ◆ **Compatible with 85% Ethanol (E85) or Methanol (M85)**



233VP Test Plug

(H11930 2" CAGE SA)

Ordering Specifications

Product #	Top Thread		Outlet Thread		Bottom Thread		Weight	
	in.	mm	in.	mm	in.	mm	lbs.	kg
233-4420 (Tee)*	4	102	2	51	4	102 Ext.	13.89	6.31
233-4430 (Tee)*	4	102	3	76	4	102 Ext.	14.06	6.39
233-4422 (Cross)*	4	102	2 x 2	51 x 51	4	102 Ext.	15.18	6.90
233-4433 (Cross)*	4	102	3 x 3	76 x 76	4	102 Ext.	15.54	7.06
233-4432 (Cross)*	4	102	3 x 2	76 x 51	4	102 Ext.	17.29	7.86

* Without cage assembly NOTE: Use OPW89 Extractor Wrenches (See page XXX)

Replacement Parts

OPW 233V and 233VM

Part #	Description
H11930	2" Cage SA
H14578M	O-Ring for 233VP-6046
233VP-6046	Test Plug

OPW 233 Series Extractor Fittings

OPW 233 Series Extractor Fittings thread into 4 NPT openings on underground storage tanks. A 4" riser pipe threads into the top of the 233 for use in Stage I Vapor Recovery or to access a ball-float. The 233 Extractor Fittings have threaded single-outlet connections for attaching tank-vent lines or multiple outlets used to manifold tank-vents or accommodate Stage II vapor-return lines from dispensers. Internal threads on the 233 are designed to install a ball-float or test plug in the extractor.

OPW 233

The OPW 233 Extractor Fittings are designed for use with all OPW 53VML Ball-Float Vent Valves that include an extractor cage (the OPW 233 does not include an extractor cage). The 233 Extractor incorporates either single-outlet or multiple-outlet threads.

OPW 233VP Extractor Test Plug

The OPW 233VP Extractor Fitting Test Plug is used on all OPW 233 Series Extractor Fittings. The 233VP incorporates an O-Ring above the threads (on the plug) to isolate the tank from the vent piping systems during a tank test.

Materials

Bushing: Iron 53

Ordering Specifications

Model #	Threads	lbs.	kg
	(MNPT x FNPT)		
53-0036	4" x 2" (102 x 51mm)	2.5	1.1



OPW 53 Bushings

OPW 53 Bushings are general-purpose bushings for use on tank-vent lines, fill lines, suction-lines or other lines where it is necessary or desirable to bush up or bush down.

Listings and Certifications



OPW 233 Series Extractor Fittings are EVR Approved for E85

OPW 53VML (30MV) Ball-Float Vent Valves

The OPW 53VML Ball-Float Vent Valves protrude into underground storage tanks from OPW 233 Series Extractor Fittings at the Stage I vapor-return riser pipe or tank-vent line. During a product delivery, as the tank level rises, a counterweight stainless-steel ball seats on the valve body and restricts flow of vapors back to the transport truck. As the vapors become compressed in the tank (ullage), product flow into the tank is severely restricted. The 53VML Series Ball-Float meets the U.S. EPA 90% requirement for product flow restriction into underground storage tanks. The 53VML-0060 and 53VML-0065 are designed as "back-up" overfill protection for overfill-prevention valves, and to minimize product mixing with underground manifold vent lines.

Ordering Specifications and Dimensions

Product #	Pipe Dia.	Length (A)		Weight	
		in.	mm	lbs.	kg
53VML-0060	2*	6 ¹ / ₈	157	2	0.9
53VML-2070	2	7	178	3	1.5
53VML-0120	2	12	305	4	1.8
53VML-0160	2	16	407	5	2.3
53VML-0180	2	18	457	6	2.7
53VML-3050	3	5	127	5	2.3
53VML-3110	3	11	279	7.6	3.5
53VML-3120	3	12	305	7.7	3.5

* 1/16" Vapor-Flow Orifice

30MV-KIT Ordering Specifications

Part #	Description
30MV-KIT	O-Ring 1/16" Brass orifice insert

Materials

- Pipe Nipple: Steel
- Coating: Black Duragard®
- Basket: Stainless-steel
- Ball: Stainless-steel

Features

- ◆ **Stainless-Steel Counterweight Ball-Float** – corrosion-resistant for long service life. Counterweight ensures proper seating of the ball for precision "slow-down" of product flow into the tank
- ◆ **Vapor-Flow Orifice** – a "bleed" hole machined into the body of the valve, sized to properly "slow-down" the delivery flow rate
- ◆ **Duragard® Body Coating** – helps prevent rust and corrosion build-up for a smooth seating surface and long service life
- ◆ **Various Body Lengths** – accommodate virtually any size tank
- ◆ **2" and 3" Body Sizes** – 3" size increases vapor flow to reduce product delivery time
- ◆ **Easy Installation, Service and Testing** – both 2" and 3" valves install in OPW 233 Series Extractor Fittings and are easily removed for inspection or tank testing with OPW 89 Extractor Wrench
- ◆ **Compatible with 85% Ethanol (E85) or Methanol (M85)**

Convert your 53VML into the 30MV Ball-Float

The 30MV Series ball-float has the same function as the 53VML, but allows for higher storage capacity in larger-volume tanks. The 30MV meets the U.S. EPA 30-minute warning requirement for product flow restriction in the underground storage tank. Using the Tank Ullage calculation on page 121, convert your desired length 53VML by adding the 30MV-KIT.

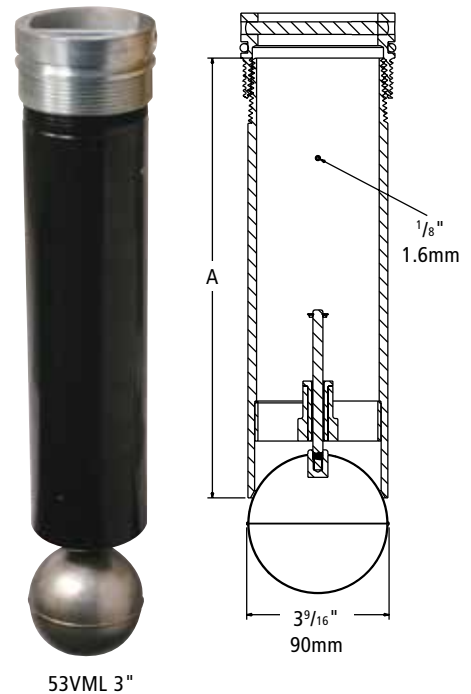
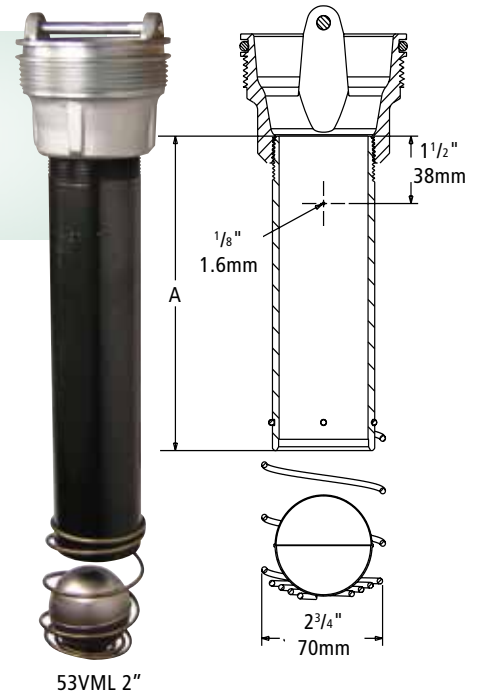

53VML/30MV Instruction Sheet
Order Number: H1411PA

Warning OPW Overfill-Warning Systems should only be used on submerged pumping systems, not suction-pump systems. For special applications, contact OPW Fueling Components. OPW Overfill-Warning Systems should only be used on gravity-drop systems. DO NOT use where Pump-Off Unloading or coax fills are used.

Specifying the Proper Length 53VML or 30MV Series Ball-Float

Step 1: Determine Dimension "X": Consult the tank chart (provided by the tank manufacturer) to determine the distance that corresponds to 10% of the total tank capacity for 53VML or 308 gallons for 30MV.

Step 2: Determine Dimension "Y": Measure the dimension from the inside top of the tank to the top of the 4" threaded tank "bung" fitting.

Step 3: Add measurements "X" and "Y". Then subtract 1/4" and round up to the nearest length ball-float.

Tank Ullage Calculator

- ◆ 30 minutes x 5GPM = 150 gallons
- ◆ Ullage-compression rate* is 27% after the ball seats
- ◆ 150 gallons ÷ .73 (1- ullage-compression rate) = 205.48 gallons
- ◆ 205.48 x 1.5 (OPW recommended safety factor) = 308.22 gallons
- ◆ Approximately 308 gallons required ullage

*Ullage-compression rate will vary with head pressure.

OPW 53VML and 30MV Ball-Float Sizing/OPW 89 Extractor Wrench

IMPORTANT:

Installing the incorrect-length OPW 53VML or 30MV Ball-Float Vent Valve for your specific application may result in delivery flow restriction at unacceptable levels. Always consult the appropriate tank charts and determine the specifics of your tank installation to determine the appropriate length OPW 53VML or 30MV. The illustration and instructions below are intended to serve as a guide in this determination.

Tank Manway Mounted Extractor

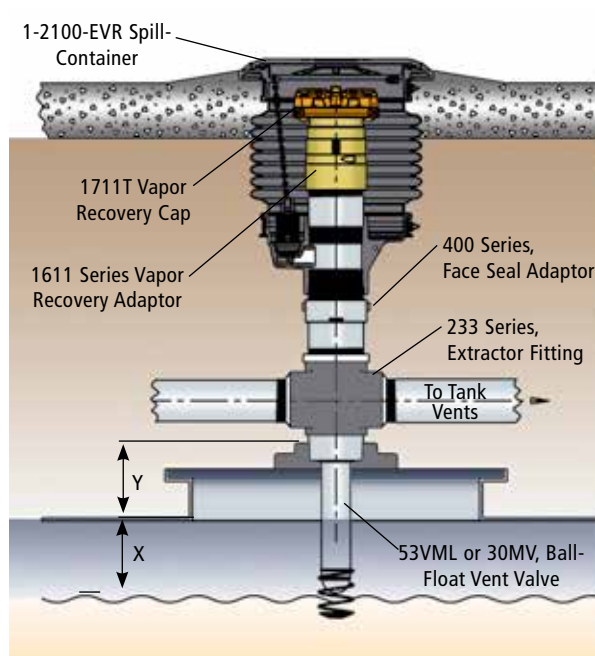

Tank Top Mounted Extractor

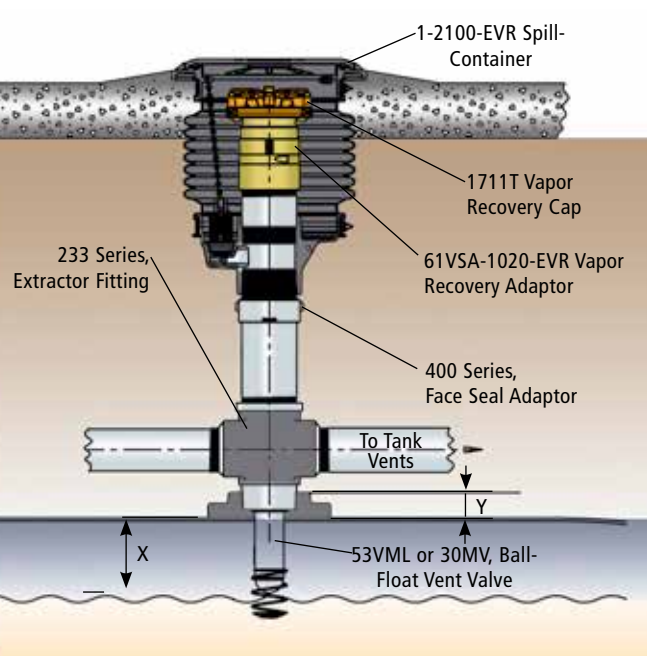

Materials

Pipe: Extra-heavy black iron
Handle and Hook: Ductile iron

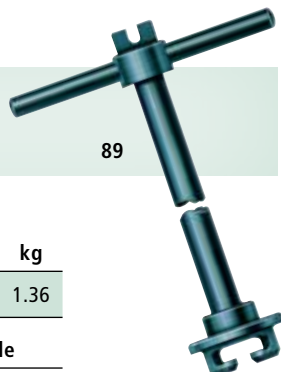

89

Ordering Specifications

Product #	in.	mm	lbs.	kg
89-0044	2	51	3	1.36

Size	Wrench	Product Compatible
2"	89-0044	233E, 88E Series

OPW 89 Extractor Wrench

The OPW 89 Extractor Wrench is designed to install or remove OPW 53VML and 30MV Ball-Float Vent Valves or OPW 233VP and 233VMP Test Plugs in OPW 233, 233V, and 233VM Extractor Fittings. The 89 is also designed to work with the cage assemblies on the 233E Suction-Tube Extractor Fitting and 88E Extractable Angle Check Valve in suction-system applications. The 89 wrench consists of a 4" section of pipe welded to a "T" handle with a 2" hook section. The 2" hook section mates with current OPW ball-floats and extractable cages.

OPW 61T Drop Tube

The OPW 61T Drop Tube is installed in the fill riser pipe to an underground storage tank. It is designed to transfer product from the fill connection point (between the delivery drop elbow and tight-fill adaptor) to within 6" (or per local requirements) of the bottom of the tank. This allows for submerged filling of the tank, resulting in a more efficient delivery flow rate while reducing the buildup of vapors or foam in the tank.

OPW 61TC Coaxial Fill Drop Tubes

The OPW 61TC Coaxial Drop Tube is designed to replace an OPW 61T Conventional Drop Tube when Stage I Vapor Recovery is required and a vapor recovery riser pipe is not available on the tank or would require excavation to the top of the tank. The 61TC is used in conjunction with OPW 633TC Coaxial Vapor Recovery Adaptors to return vapors to the tank truck through one riser pipe during a fuel delivery to an underground storage tank. The upper section of the 61TC is tapered to allow vapors to return to the tank truck through the interstitial space between the riser pipe and outside wall of the drop tube. Simultaneously, product is delivered to the tank through the center of the 61TC.

OPW 61TCP Poppeted Coaxial Fill Drop Tubes

The OPW 61TCP Poppeted Coaxial Fill Drop Tube is similar to the 61TC, but is spring-loaded. When used in conjunction with the OPW 633TCP, the 61TCP acts as a poppet to close off the vapor-return side of the coaxial-fill tube.



Features

- ◆ **.062" Thick Drop Tube Walls** – deter denting and damage to the tube upon installation or removal for long service life.
- ◆ **Various Lengths and Diameters** – accommodate a variety of tank diameters and fill riser pipe sizes.

Ordering Specifications

Product #	Diameter		Weight		Drop Tube Length	
	in.	mm	lbs.	kg	ft.	m
61T-7368	4	102	7.65	3.48	15	4.57
E85 EVR Approved:						
61T-SS-0417	4	102	13	5.9	19	5.19
61T-DEF-0412*	4	102	6.18	2.8	12	3.66

Replacement gaskets for the 61T-4" and the 61SO Series are available. Order the OPW 61TG (4000).

*For DEF Applications Only

Features

- ◆ **.052"-Thick Drop-Tube Walls** – deter denting and damage to the tube upon installation or removal for long service life
- ◆ **Various Lengths and Diameters** – accommodate a variety of tank diameters and fill riser pipe sizes
- ◆ **Fully Welded Retaining Brackets** – ensure a secure installation in the riser pipe
- ◆ **Three Centering Springs** – enable even flow of vapors back to the tank truck

Ordering Specifications

Product #	Diameter		Length		Weight	
	in.	mm	ft.	m	lbs.	kg
61TC-7270	4	102	13	3.96	8.64	3.93
61TC-7272	4	102	16	4.88	13.82	6.28
61TCP-3800	4	102	13	3.96	8.96	4.07

61T Drop Tube Instruction Sheet Order Number: **200652**

61TCP-3800 Instruction Sheet Order Number: **H12064M**

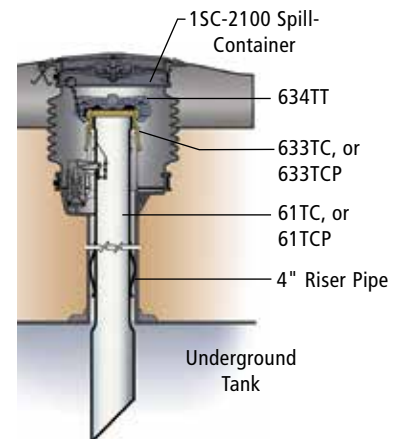

Materials

Body: Aluminum and stainless-steel components

Viton® Base Pad

6111-1400

Features

- ◆ **Viton® Base Pad** – ensures compatibility with current fuel formulations and absorbs impact of wooden gauge sticks to protect the bottom of the tank from punctures
- ◆ **Corrosion-Resistant** – aluminum and stainless-steel components provide for long service life
- ◆ **Unencumbered Vertical Movement** – assures the pad rests on the bottom of the tank and absorbs shock evenly
- ◆ **CARB Approved** – approval Letter #98-12
- ◆ **EVR Approved**

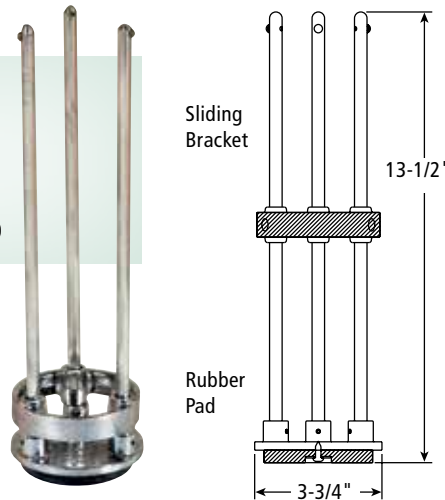

Ordering Specifications

Product #	Height		Diameter		Weight	
	in.	mm	in.	mm	lbs.	kg
6111-1400	13 1/2	343	3 3/4	96	3	1.4

OPW Tank-Bottom Protectors

OPW Tank-Bottom Protectors are installed at the bottom of overfill-prevention valves or drop tubes to help prevent the underground storage tank from damage or leakage at the fill point due to manual tank-gauging with wooden sticks and erosion from dirt or debris.

OPW 6111-1400 Tank-Bottom Protector

The OPW 6111-1400 incorporates a sliding bracket that is pop-riveted to the bottom of the drop tube. This secures the tank-bottom protector to the drop tube for easy, reliable installation and removal for servicing the tank.

Features

- ◆ **Zinc-Plated Steel Cage** – ensures corrosion resistance for long service life
- ◆ **Mesh Screen Design** – helps prevent debris or other foreign matter from obstructing the submersible pump or suction-line foot valve

Ordering Specifications

Product #	Height		Weight	
	in.	mm	lbs.	kg
61TP-2398	4	102	1.02	.46

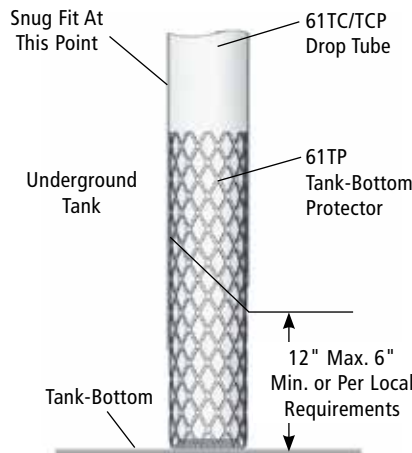

OPW 61TP Tank-Bottom Protector

The OPW 61TP is a flanged, mesh screen design that slides to the bottom of the drop tube. The 61TP is held in place by the flanged spring action of the mesh screen. The mesh screen helps keep debris or other foreign matter from obstructing the submersible pump or suction-line foot valve.

6111-1400 Tank-Bottom Protector Instruction Sheet
Order Number: **H14977PA**

OPW 723V Pressure Vacuum Vents

Pressure Vacuum Vents are installed on the top of vent pipes from underground or aboveground fuel-storage tanks. The vent-cap and internal wire screen are designed to protect the tank-vent lines against intrusion and blockage from water, debris or insects. A normally closed poppet in the valve opens at a predetermined pressure or vacuum setting to allow the tank to vent.

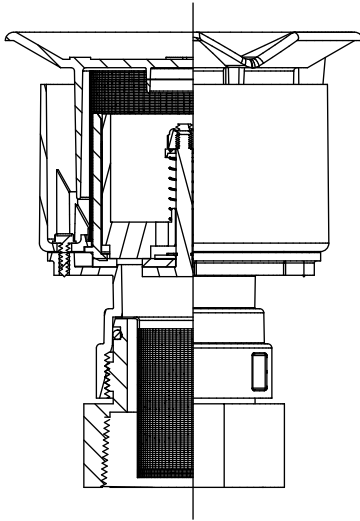

Conversion Table

Measurement Units	=	Oz.	PSI	In H ₂ O (WC)	In Hg (Merc)	Bar
Bar	x	236.0	14.5	401.4	29.53	
In. Hg (Mercury)	x	7.843	0.49	13.6		0.034
In H ₂ O (WC)	x	0.578	0.04		0.074	0.002
PSI	x	16.00		27.68	2.04	0.069
Oz.	x		0.063	1.73	0.128	0.004

Materials

- Top/Body:** Polypropylene
- Base:** Anodized aluminum
- Poppet:** Anodized aluminum
- Screen:** Stainless-steel mesh
- Gasket:** Cellular rubber



723V

Vent Must Be Mounted Vertically



Features

- ◆ **Preset and Tested Factory Settings** - 2.5" to 6" water-column pressure settings and -6" to -10" water-column vacuum settings
- ◆ **Cycle Tested For Reliability** - tested to the equivalent of 80 years of service in the most severe environment without leakage problems
- ◆ **Long Service Life** – corrosion-resistant Duratuff® composite construction
- ◆ **Easy Installation** – the 723V is available in 2" and 3" threaded versions
- ◆ **Certifications** – California Air Resources Board and Enhanced Vapor Recovery (CARB EVR)
- ◆ **UL Approved to CARB CP-201 Requirements**
- ◆ Underwriters Laboratory 2583 Listed
- ◆ Complies with NFPA 30 Requirements for venting gasoline vapors upward
- ◆ **High Maximum Flow Rate** – 6450 SCFH at 2 psi (0.1 bar) pressure drop
- ◆ **Manifold Vent Pipes** – vent pipes may be manifolded to produce a single Pressure Vacuum Vent line. The 723V exceeds California's requirements of a maximum vapor leak rate of 0.17 SCFH at 2.00 inches H₂O
- ◆ **Leak Rate** – multiple pressure vacuum vents may be installed on a single site. The 723V exceeds California standards with a leak rate of 0.05 SCFH or less at 2.00 inches H₂O
- ◆ **Screened Tank Vent Lines** – a 65-micron stainless-steel screen helps prevent debris and insects from entering the lines. An added screen installed at the base prevents debris from intruding from the vent stack
- ◆ **No Tools Required** – A removable snap-fit top allows for easy maintenance (recommended yearly)
- ◆ **Removable Threaded Bushing** – designed for easy installation on NPT-threaded risers. Allows easy access to lower screen

723V Instruction Sheet
Order Number: 211276

Listings and Certifications



Ordering Specifications

Product #	Description	Identification Label Color	lb.	kg
723V-2203	2" Thread, 2" to 3" WC Pres., 8" WC Vac., 2" NPT, Thread-On	Yellow	1.55	.70
723V-3203	3" Thread, 2" to 3" WC Pres., 8" WC Vac., 3" NPT, Thread-On	Yellow	2.20	1.00

Replacement Parts

Part Number	Description
C05086M	Lower Screen
209817	Upper Screen
C05089	2" Threaded Base Adaptor
C05122	3" Threaded Base Adaptor

OPW 623V Pressure Vacuum Vent

Pressure Vacuum Vents are installed on the top of vent pipes from underground or aboveground fuel-storage tanks. The vent-cap and internal wire screen are designed to protect the tank-vent lines against intrusion and blockage from water, debris or insects. A normally closed poppet in the valve opens at a predetermined pressure or vacuum setting to allow the tank to vent.

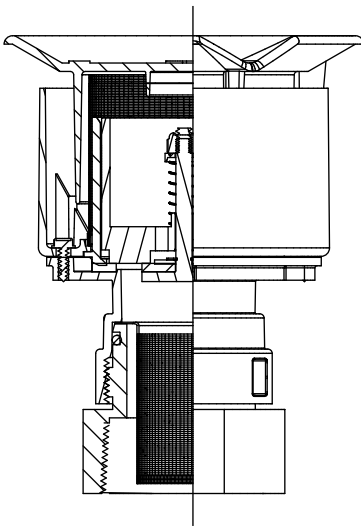

Materials

- Top/Body:** Polypropylene
- Base:** Anodized aluminum
- Poppet:** Anodized aluminum
- Screen:** Stainless-steel mesh
- Gasket:** Closed-cell foam



623V
Vent Must Be Mounted Vertically

Features

- ◆ **Pressure/Vacuum Setting** – 2.5" to 6" water-column pressure settings and -6" to -10" water-column vacuum settings are factory preset and tested
- ◆ **Reliable Service** – cycle tested to the equivalent of 80 years of service in the most severe environment without leakage problems
- ◆ **Corrosion-Resistant Construction** – a Duratuff® composite body ensures a long service life
- ◆ **Easy Installation** – the 623V is available in 2" and 3" threaded versions
- ◆ **Complies with NFPA 30 Requirements** – for venting gasoline vapors upward
- ◆ **Manifold Vent Pipes** – vent pipes may be manifolded to produce a single Pressure Vacuum Vent line. The 623V is designed to exceed California's requirements of a maximum vapor leak rate of 0.17 SCFH at 2.00 inches H₂O
- ◆ **High Maximum Flow Rate** – 6450 SCFH at 2 psi (0.1 bar) pressure drop
- ◆ **Leak Rate** – multiple pressure vacuum vents may be installed on a single site. The 623V exceeds California standards with a leak rate of 0.05 SCFH or less at 2.00 inches H₂O
- ◆ **Maintenance** – no tools required. A removable snap-fit top allows for easy maintenance (recommended yearly)
- ◆ **100-Mesh Stainless-Steel Wire Screens** – helps prevent debris and insects from entering the tank-vent lines. An added screen installed at the base prevents debris from intruding from the vent stack
- ◆ **Adaptor Bushing** – removable hex-threaded bushing designed for easy installation on NPT-threaded risers. Allows easy access to lower screen
- ◆ **ATEX Approved** – for flame-arrestor applications

Ordering Specifications

Product #	Description	Identification Label Color	lb.	kg
623V-2203	2" Thread, 2.5" to 6" WC Pres., -6" to -10" WC Vac. Thread-On	Yellow	1.55	.70
623V-3203	3" Thread, 2.5" to 6" WC Pres., -6" to -10" WC Vac. Thread-On	Yellow	2.20	1.00

Replacement Parts

Part #	Description
C05086M	Lower Screen
H14895M	Upper Screen
C05089	2" Threaded Base Adaptor
C05122	3" Threaded Base Adaptor

Conversion Table						
Measurement Units		Oz.	PSI	In H ₂ O (WC)	In Hg (Merc)	Bar
Bar	=					
	x	236.0	14.5	401.4	29.53	
In. Hg (Mercury)	x	7.843	0.49	13.6		0.034
	x	0.578	0.04		0.074	0.002
In H ₂ O (WC)	x	16.00		27.68	2.04	0.069
	x		0.063	1.73	0.128	0.004

623V Instruction Sheet
Order Number: H14898M

Listings and Certifications



OPW 623V & 523V



ATEX Approved

Patent No.
WO2004/036096AZ

Features

- ◆ **A Variety of Pressure/Vacuum Settings** – 3" water-column, 1 oz. and 8 oz. pressure settings and 8" water-column or 1/2 oz. vacuum settings are factory preset and tested
- ◆ **Reliable Service** – self-guided poppet assembly ensures consistent seating of the pressure/vacuum valve
- ◆ **Corrosion-Resistant Construction** – Duratuff® composite body assures long service life
- ◆ **Easy Installation** – 523V is available in 2" and 3" threaded versions or slip-on models that provide for attachment to the vent line with Allen-head screws and radial sealing O-ring



- ◆ **Complies with NFPA 30 Requirements** – for venting gasoline vapors upward
- ◆ **High Maximum Flow Rate** – 7000 SCFH at 2 psi pressure drop
- ◆ **40-Mesh Stainless-Steel Wire Screen** – helps prevent debris and insects from entering the tank-vent lines

OPW 523V Pressure Vacuum Vent

Pressure Vacuum Vents are installed on the top of vent pipes from underground or aboveground fuel-storage tanks. The vent-cap and internal wire screen are designed to protect the tank-vent lines against intrusion and blockage from water, debris or insects. A normally closed poppet in the valve opens at a predetermined pressure or vacuum setting to allow the tank to vent.

Ordering Specifications

Product #	Description	Identification Label Color	lb.	kg
523V-1100	2" 8 oz Pres., 1/2 oz. vac. thread-on	Red	1.65	.75
523V-1150	2" 8 oz Pres., 1/2 oz. vac. slip-on	Red	1.65	.75
523V-3100	3" 8 oz Pres., 1/2 oz. vac. thread-on	Red	3.2	1.45
523V-3150	3" 8 oz Pres., 1/2 oz. vac. slip-on	Red	3.2	1.45
523V-2200	2" 1 oz Pres., 1/2 oz. vac. thread-on	Silver	1.65	.75
523V-2250	2" 1 oz Pres., 1/2 oz. vac. slip-on	Silver	1.65	.75
523V-3200	3" 1 oz Pres., 1/2 oz. vac. thread-on	Silver	3.2	1.45
523V-2203	2" 3" WC Pres., 8" WC vac. thread-on	Yellow	1.65	.75
523V-2253	2" 3" WC Pres., 8" WC vac. slip-on	Yellow	1.65	.75
523V-3203	3" 3" WC Pres., 8" WC vac. thread-on	Yellow	3.2	1.45
523V-3253	3" 3" WC Pres., 8" WC vac. slip-on	Yellow	3.2	1.45

Conversion Table

Measurement Units		Oz.	PSI	In H ₂ O (WC)	In Hg (Merc)	Bar
Bar	=					
	x	236.0	14.5	401.4	29.53	
In. Hg (Mercury)	=					
	x	7.843	0.49	13.6		0.034
In H ₂ O (WC)	=					
	x	0.578	0.04		0.074	0.002
PSI Oz.	=					
	x	16.00		27.68	2.04	0.069
	x	0.063	1.73	0.128	0.004	

Replacement Parts

Part #	Description
H11432M	O-Ring for 2" Thread
H11456M	O-Ring for 3" Thread

523V Instruction Sheet
Order Number: **H11972M**

Materials

Body: Aluminum
O-Ring: Nitrile



OPW 523V Series Adaptor Bushings

The 523V Series Adaptor Bushings are designed to thread into the base of 2" threaded 523V vents. The adaptor bushings convert a 2" 523V to 3" threaded, 2" slip-on or 3" slip-on connection.

Ordering Specifications

Product #	Description	in.	mm	lb.	kg
523A-1003	3" Thread-On Adaptor for use with 523V Pressure / Vacuum Vents	2x3	51x76	.47	.213
523SA-1003	3" Slip-On Adaptor for use with 523V Pressure / Vacuum Vents	2x3	51x76	.63	.286
523SA-1002	2.5" Slip-On Adaptor for use with 523V Pressure / Vacuum Vents	2x2	51x51	.31	.141

Materials

Body: Aluminum
Screen: 40-mesh brass
Set Screws: Brass



23

Features

- ◆ **Reliable Service** – vent-cap drain spouts extend outward to deter rainwater entry
- ◆ **Corrosion-Resistant Construction** – aluminum body and cap assure a long service life
- ◆ **Easy Installation** – 23 series is available in 2" and 3" slip-on models that provide for attachment to the vent line with set screws
- ◆ **Complies with NFPA 30 Requirements** – for venting gasoline vapors upward

- ◆ **High Maximum Flow Rate** – 7000 SCFH at 2 psi (0.1 bar) pressure drop
- ◆ **40-Mesh Brass Wire Screen** – helps prevent debris and insects from entering the tank-vent lines

Replacement Parts

Part #	Description
H00122M	Screw
H01967M	Nut
H01969M	Screen

Ordering Specifications

Product #	Description	Weight					
		in.	mm	lbs.	kg	lbs.	kg
23-0044	Open Vent	1½	38	.25	0.11	0.25	0.11
23-0033	Open Vent	2	51	.25	0.11	0.25	0.11
23-0055	Open Vent	3	76	1.6	0.73	1.00	0.45

OPW 23 Series Open Atmospheric Vents

Open Atmospheric Vents are installed on the top of vent pipes from underground or aboveground fuel-storage tanks. The vent-cap and internal wire screen are designed to protect the tank-vent lines against intrusion and blockage from water, debris or insects. These vents are always open to atmosphere and allow any pressure or vacuum in the tank to vent.

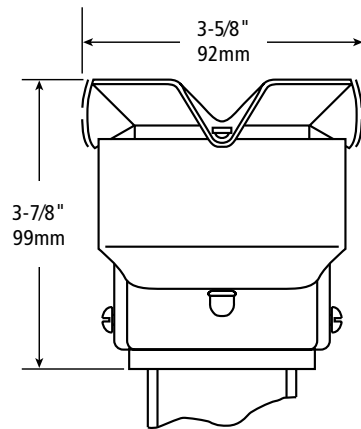

Materials

Body: Zinc/aluminum
Screen: brass
Cap: 2" - Steel 4" - cast-iron
Screen: 40-mesh stainless-steel



113

Ordering Specifications

Product #	Weight			
	in.	mm	lbs.	kg
113-0099	4	102	7.50	3.41

OPW 113 Series Open Atmospheric Utility Vents

OPW 113 Open Atmospheric Utility Vents are installed on the top of above ground fuel-storage tanks. The vent-cap and internal wire screen are designed to protect the tank-vent lines against intrusion and blockage from water, debris or insects. These vents are always open to atmosphere and allow any pressure or vacuum into the tank to vent. The 113 vents vapors downward and is used primarily on diesel, fuel oil, waste-oil and motor-oil tanks, but can also be used on a wide variety of aboveground storage tank-venting applications.

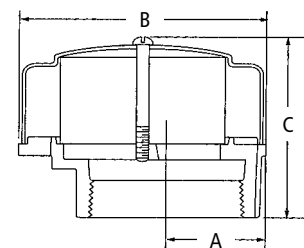

Manholes & Monitoring Well Equipment



Fibrelite Composite Access Covers

Fibrelite manufactures the widest range of composite manhole covers for the Retail Fueling industry. After 30 years Fibrelite remains number one in the market, supplying globally innovative new designs.

Manholes & Monitoring Well Equipment

OPW Manholes are designed for use in a wide variety of service station, commercial and industrial driveway applications. They provide access from grade-level to underground equipment including tank sumps, tank riser pipes, monitoring equipment, submersible pumps, valves and piping connections.

Composite Manholes

Lightweight and extremely durable, composite cover manholes make sump accessibility safer and easier than ever before. Designed for use in many service station, commercial and industrial driveway applications, these manholes offer a wide variety of features to ensure the ultimate in safety, user-friendly convenience and long-lasting performance.

Cast-Iron Manholes and Fill Boxes

Heavily ribbed cast-iron covers and body rings ensure maximum load-bearing capacity on cast-iron manholes and fill boxes. These manholes are ideal for connecting underground tank lines directly to the surface without sump enclosures. A variety of features available on cast-iron manholes and fill boxes make them the perfect choice for many applications.

Steel Manholes

Steel Manholes are designed for use in a variety of service station driveway, industrial and commercial applications, and are used to provide access to all types of underground equipment, including vapor recovery connections, UST monitoring equipment, submersible pumps and tank-gauging equipment.

Monitoring Well Manholes

OPW Monitoring Well Manholes are designed for monitoring and observation well applications where limited access and clear identification are essential. Rugged cast-iron covers meet H20/HS20 load rating requirements for long-lasting and reliable performance. The covers feature a permanently cast-in "Do Not Fill" warning statement and a black equilateral triangle inset into a white background in accordance with API Recommended Practice 1615.

OPW Manhole Covers Exceed Highway Specification-20 (H20/HS20)

Highway Specification-20 (H20/HS20) is contained in the "Standard Specifications for Highway Bridges" and is intended to serve as a standard or guide of preparation of state specifications.

H20/HS20 incorporates rear-axle loading of 32,000 lbs. over rear-axle (4 wheel on single axle) or wheel loading of 8,000 lbs. per tire.

These sketches illustrate the AASHTO-approved live-loading specifications for the standard H20 and HS20 trucks.

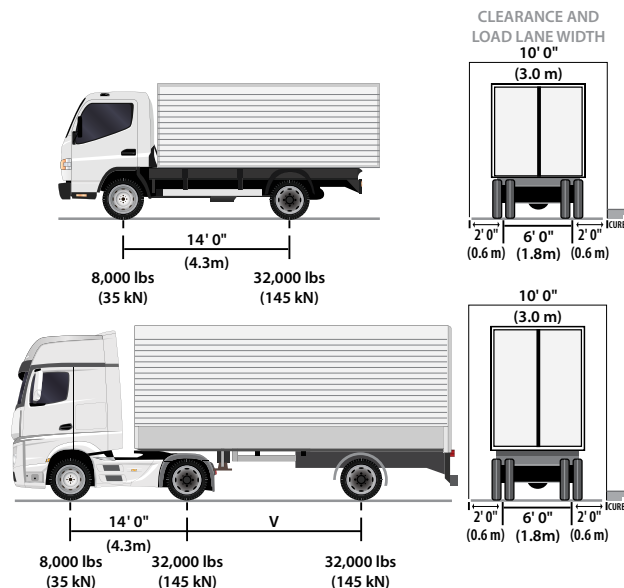

Fibrelite Composite Manholes

Fibrelite offers the retail-petroleum industry's leading watertight, easy to remove, non-bolted composite manhole covers in a large selection of shapes and sizes. From general tank sump access to multiport and single-port fill-sump applications to interstitial sumps and monitoring-wells, Fibrelite has every application covered.

Multiple colors are available – Contact OPW Customer Service for pricing, availability, and lead times.

Materials:

Cover: Fiberglass

Frame: Fiberglass

Skirt: Fiberglass

Cover Includes Frame and Skirt



Features & Benefits:

- ◆ UV resistant
- ◆ Round, square and rectangular (wide range of sizes)
- ◆ Anti-slip surface - no costly injury claims
- ◆ Will not corrode
- ◆ Watertight, sealed design
- ◆ No bolts required
- ◆ Monolithic structure eliminates delaminating
- ◆ Ergonomic, single-person removal and replacement with Fibrelite lifting handle
- ◆ Locks available for all covers
- ◆ Available in any color
- ◆ Heavy-duty (HD40) covers available for truck stops, bus depots and industrial applications

Complete Cover Assemblies

Ordering Specifications - Complete Grade Level "Flat" Composite Manholes



FL90-SK12

Part #	Description	Color	Skirt I.D.	Cover O.D.	Skirt Length	Skirt Style	Wt.
FL120BLACK-SK12	12" Black Flat Composite Manhole Cover Bonded	Black	13"	15"	12"	Tapered	26 lbs
FL180BLACK-SK12	18" Black Flat Composite Manhole Cover Bonded	Black	19"	21.2"	12"	Tapered	40 lbs
FL600BLACK-SK12	24" Black Flat Composite Manhole Cover Bonded	Black	26"	27"	12"	Tapered	76 lbs
FL760BLACK-SK12	30" Black Flat Composite Manhole Cover Bonded	Black	32"	33"	12"	Tapered	89 lbs
FL90BLACK-SK12	36" Black Flat Composite Manhole Cover Bonded	Black	37"	38.5"	12"	Tapered	109 lbs
FL90GRAY-SK12	36" Gray Flat Composite Manhole Cover Bonded	Gray	37"	38.5"	12"	Tapered	109 lbs
FL100BLACK-SK12	40" Black Flat Composite Manhole Cover Bonded	Black	42"	44"	12"	Stepped	142 lbs
FL100GRAY-SK12	40" Gray Flat Composite Manhole Cover Bonded	Gray	42"	44"	12"	Stepped	142 lbs

Contact OPW for custom length skirts, heavy duty or colored covers 1-800-422-2525.

Replacement Parts - Replacement Covers

Part #	Description	Color	Cover O.D.	Cover Ht.	Wt.
FL120BLACK	12" Dia. Black Flat Sealed Composite Cover	Black	15"	3.91"	13 lbs
FL180BLACK	18" Dia. Black Flat Sealed Composite Cover	Black	21.2"	3.84"	22 lbs
FL600BLACK	24" Dia. Black Flat Sealed Composite Cover	Black	27"	3.84"	46 lbs
FL760BLACK	30" Dia. Black Flat Sealed Composite Cover	Black	33"	3.84"	59 lbs
FL90BLACK	36" Dia. Black Flat Sealed Composite Cover	Black	38.5"	3.84"	75 lbs
FL100BLACK	40" Dia. Black Flat Sealed Composite Cover	Black	44"	3.84"	110 lbs
FL100GRAY	40" Dia. Gray Flat Sealed Composite Cover	Gray	44"	3.84"	110 lbs
FL36BLACK	36" Dia. Black Raised Composite Cover	Black	39.5"	3.84"	66 lbs
FL36GRAY	36" Dia. Gray Raised Composite Cover	Gray	39.5"	3.84"	66 lbs
FL42BLACK	42" Dia. Black Raised Composite Cover	Black	46.5"	3.84"	93 lbs

*Add HD to Part Numbers above to specify Heavy-Duty H25/HS25-Rated Covers



FL100-SK12



FL90

Ordering Specifications

Frames "Mounting Frame"

Part #	Description	Skirt I.D.	Manhole Type	Weight (lbs)
FL120F	12" Composite Frame For FL120 Covers	13"	Flat	7.7
FL180F	18" Flat Composite Frame For FL180 Covers	19"	Flat	11
FL600F	24" Flat Composite Frame For FL600 Covers	26"	Flat	17
FL760F	30" Flat Composite Frame For FL760 Covers	32"	Flat	18
FL90F	36" Flat Composite Frame For FL90 Covers	37"	Flat	20
FL100F	40" Composite Frame For FL100 Covers	42"	Flat	26

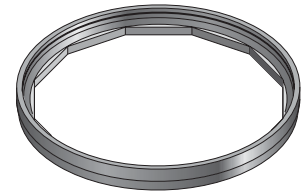

Frames - Flat Fiberglass Mounting Ring

Ordering Specifications

Skirts

Part #	Description	Skirt I.D.	Skirt Length	Skirt Style	Weight (lbs)
FL120-SK12	12" Deep FRP Skirt To Fit FL120	13"	12"	Tapered	5
FL180-SK12	12" Deep FRP Skirt To Fit FL180	19"	12"	Tapered	7
FL600-SK12	12" Deep FRP Skirt To Fit FL600	26"	12"	Tapered	10
FL760-SK12	12" Deep FRP Skirt To Fit FL760	32"	12"	Tapered	12
FL90-SK12	12" Deep FRP Skirt To Fit FL90 Flat	37"	12"	Tapered	14
FL100-SK12	12" Deep FRP Skirt To Fit FL100	42"	12"	Stepped	16



FL90-SK12

Ordering Specifications

Cover Accessories

Part #	Description
FL7	Lifting Handle For Raised Covers - FL42/FL36
FL7A	Lifting Handle With Foot Pedal For Watertight Covers - FL100/FL90/FL180
FL7A-ENCL	Enclosure To House FL7A Handles
KEY-HREP-10-76-90	Key Housing Repair Kit & Compound
FIB-KHB	Replacement Rubber Bung
FIB-KHP	Rubber Key Housing Plug
FIB2-RL-KEY	Key For FIB2-RL Cover Lock
FL120-SEAL	12" Replacement Gasket For FL120
FL180-SEAL	18" Replacement Gasket For FL180
FL600-SEAL	24" Replacement Gasket For FL600
FL760-SEAL	30" Replacement Gasket For FL760
FL90-SEAL	36" Replacement Gasket For FL90
FL100-SEAL	40" Replacement Gasket For FL100

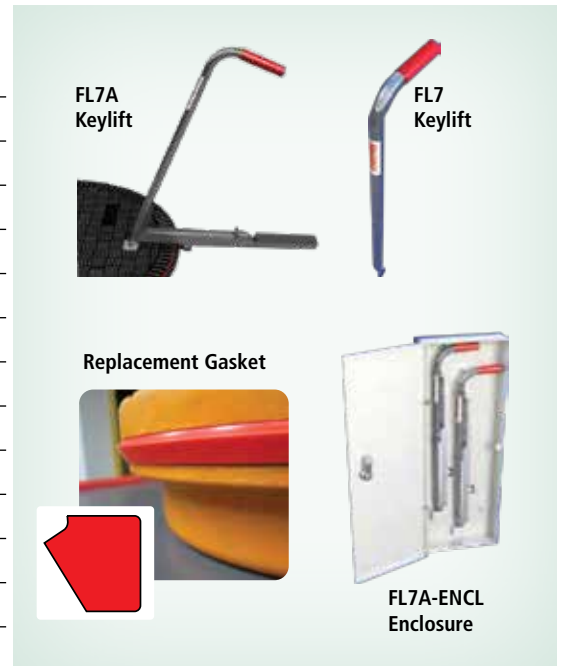

FL7A Keylift

FL7 Keylift

Replacement Gasket

FL7A-ENCL Enclosure

OPW Conquistador™ Plus Composite Cover Manholes

Lightweight and extremely durable, composite cover manholes make sump accessibility safer and easier than ever before. Designed for use in many service station, commercial and industrial driveway applications, these manholes offer a wide variety of features to ensure the ultimate in user-friendly convenience and long-lasting performance.

The Conquistador™ Duratuff® helps put an end to the risk of back, foot and hand injuries with a slip-resistant tread pattern and lightweight, low-profile construction for easier and safer access to tank sumps and other underground equipment.



Replacement Parts

Product #	Description
New Recessed Handle Replacement Parts	
205749	Handle
203174	Screw
Recessed Handle Replacement Parts	
RPHK	Replacement Handle Kit
H13439M	Handle
H13441M	Weld Nut
H14462M	Screw
H11620M	Washer

Features

- ◆ Slip-resistant tread pattern
- ◆ Easy removal and replacement
- ◆ Two lifting options; stainless-steel recessed handle or key-lift provision
- ◆ Reduced risk of back, foot and hand injuries
- ◆ Unmatched deflection performance
- ◆ Outstanding long-term durability in rigorous cycle tests
- ◆ Three mounting options
- ◆ Unique structural fiberglass reinforcement matrix
- ◆ Water-resistant models available
- ◆ Roto-Lock and Bolt-Down models available
- ◆ Interchangeable with other manufacturers' covers
- ◆ Painted ring and brass bolts help to prevent rust and corrosion



- ◆ Ribbed gasket peel and stick design for easy replacement
- ◆ Roto-Lock Models – for securing a rain-tight connection without the need to locate threaded bolt holes on the mounting ring. The Roto-Lock offers quick and easy access, while maintaining a secure sump application
- ◆ H20/HS20 Rating – Exceeds Highway Specification - 20 (H20/HS20) Rating

Lifting Options

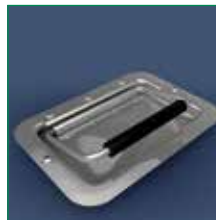

NEW Recessed Handle 203666



Recessed Handle RPHK

Replacement Handles and Keylifts by Model Year

Item	Part #	Conquistador Model Years	Description
Replacement Handle	RPHK	2000-2008	2 Thru Hole Bolt Pattern Design Handle
Replacement Handle	203666	2009-Present	2 Threaded Hole Bolt Pattern Design Handle

Materials

- Cover:** Fiberglass
- Ring:** Painted steel
- Skirt:** Galvanized steel
- Key Lift / Recessed Handles:** Stainless-steel
- Bolts:** Stainless-steel
- Roto-lock:** Brass



Dimensions

Cover	A (Ring I.D.)		B (Skirt I.D.)		Cover Wt.		Assembly Wt.	
39 1/2"	36 1/8"	92 cm	38 3/8"	98 cm	76 lbs.	34.4 kg	134 lbs.	60.8 kg
44 1/4"	40 29/32"	104 cm	43 3/8"	110 cm	89 lbs.	40.4 kg	163 lbs.	74 kg

Ordering Specifications

Plain Cover-Grey

Product #	Description	Cover Only
39CD-PL10	39 1/2" Plain Cover w/ Recess Handle	E00618
44CD-PL10	44 1/4" Plain Cover w/ Recess Handle	E00626

Bolt-Down Cover-Grey

Product #	Description	Cover Only
39CD-WT10	39 1/2" Bolt Down Cover w/ Recess Handle	E00622
44CD-WT10	44 1/4" Bolt Down Cover w/ Recess Handle	E00630

Roto-Lock Cover-Grey

Product #	Description	Cover Only
39CD-RL10	39 1/2" Roto-Lock w/ Recess Handle	E00714
44CD-RL10	44 1/4" Roto-Lock w/ Recess Handle	E00713

Steel Cover Only

Product #	Description
P110-3950L	39 1/2" Plain Cover Only
P110-4425L	44 1/4" Plain Cover Only

OPW Conquistador™ Plus Composite Cover Manholes

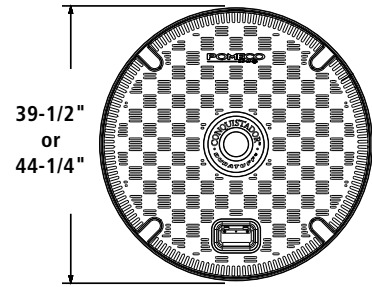

Cover 1" Thick

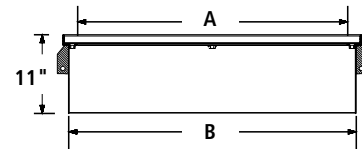

Mounting Options:

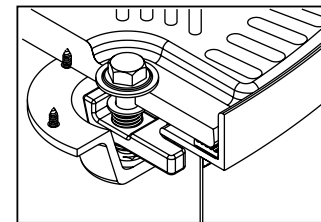
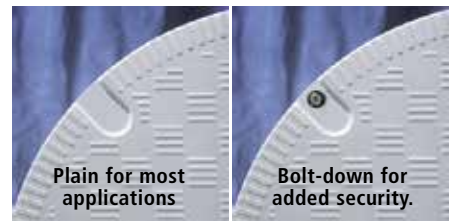

Roto-Lock Fastening System

Key Lift Provision Stick

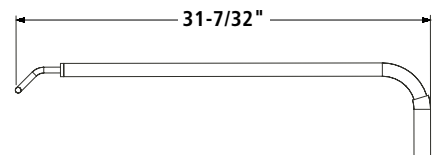

Replacement Parts

Product #	Description
90K-KLS	Key-Lift Provision Stick
H14858	Replacement Gasket for 39CD and 44CD
H14460M	Replacement Bolts
H14461M	Replacement Washers
1RL-KIT	Replacement Roto-Lock Kit



Gain independence from heavy steel covers with this all-new composite cover. OPW engineered the Matador with next-generation composite technology to make it the lightest cover in the industry, and priced it to compete with any cover on the market for use at petroleum retail operations, in addition to use for commercial and industrial driveway applications.

Available in 37" and 42" options, the Matador Composite Cover is lightweight, water resistant and extremely durable. Standout features include a steel frame, stainless-steel recessed lift handle and a polyethylene skirt with a flair that prevents corrosion and rust. The lightweight design and slip-resistant tread pattern helps to prevent the risk of back, foot and hand injuries. The Matador makes sump accessibility safer and easier than ever before.

Materials

- Cover:** Fiberglass
- Ring:** Painted Steel
- Skirt:** Polyethelene
- Recessed Handle:** Stainless-steel
- Roto Locks:** Ductile iron



Features & Benefits

- ◆ **Lightweight design helps to reduce risk of back, foot and hand injuries**
- ◆ **Slip-resistant tread pattern**
- ◆ **Water resistant**
- ◆ **Easy removal and replacement**
- ◆ **Stainless-steel recessed handle**
- ◆ **Exceptional deflection performance**
- ◆ **Long-life performance** – comparable to heavier competitor models in cycle tests
- ◆ **Special structural fiberglass reinforcement matrix**
- ◆ **Two mounting options**
- ◆ **Roto-Lock Option** – for providing a secure locking mechanism without the need to locate threaded bolt holes on the mounting ring. The Roto-Lock offers quick and easy access while maintaining a secure sump application.
- ◆ **Painted steel frame**
- ◆ **Polyethylene skirt with flair**
- ◆ **H20/HS20 Rating** – Exceeds Highway Specification – 20 (H20/HS20) Rating
- ◆ **Flared skirt allows equivalent water percolation to 39" and 44" covers**

Performance Chart

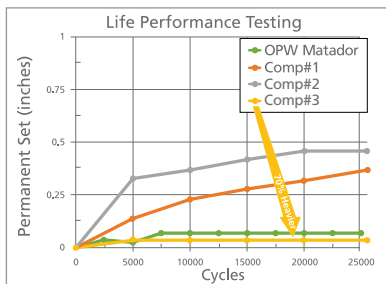

Ordering Specifications

Product #	Description	Covers Only	lb.	kg
37MAT-PL12	37" Plain Matador Composite Cover, Includes Ring and Skirt	212529	63.00	28.58
37MAT-CM12	37" Cam-Lock Matador Composite Cover, Includes Ring and Skirt	212168	66.00	29.94
42MAT-PL12	42" Plain Matador Composite Cover, Includes Ring and Skirt	212518	83.00	37.65
42MAT-CM12	42" Cam-Lock Matador Composite Cover, Includes Ring and Skirt	212164	87.00	39.46
203666	Replacement Handle Kit (same as conquistador)	Equivalent to Conquistador replacement numbers		
205749	Replacement Handle Only (same as conquistador)			
203174	Replacement Handle Screw Only (same as conquistador)			
1CL-KIT	Replacement Cam Kit			

Dimensions

Cover	A (Ring I.D.)		B (Skirt I.D.)		Assembly Weight (Plain)		Assembly Weight (Cam-Lock)	
37.50	35.50 in	90.17 cm	38.62 in	98.09 cm	83.00 lbs	37.63 kg	105.00 lbs	47.63 kg
42.00	40.00 in	101.60 cm	43.50 in	110.49 cm	86.00 lbs	39.00 kg	109.00 lbs	49.44 kg

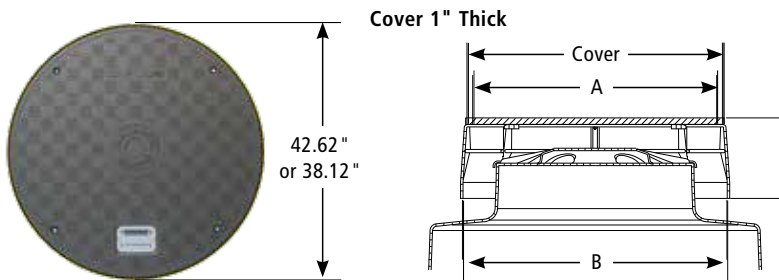

OPW 104C Composite Cover Manholes

The OPW 104C 20" (500mm) Composite Cover Manholes allow easy access to UST-monitoring equipment and provide additional space for electrical junction boxes.

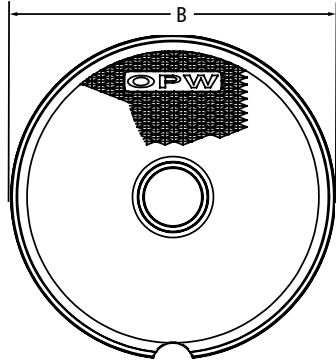

OPW 104C Cover

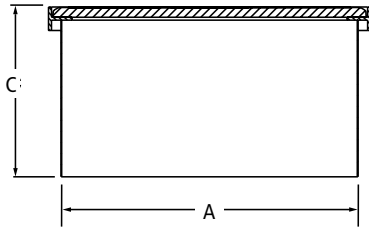

OPW 104C Composite Cover Manholes

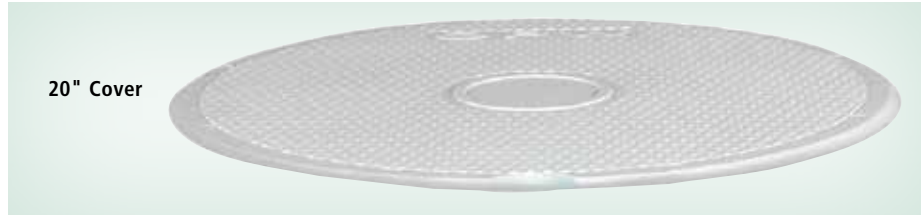

20" Cover

Features

- ◆ **Lightweight Cover** – provides safe, easy removal and replacement
- ◆ **Durable Composite Construction** – never rusts, fades or needs to be painted
- ◆ **Spark-Free Cover Design** – fiberglass construction eliminates the possibility of sparks caused by replacing cover on mounting ring
- ◆ **Flush-Mount, Rolled Steel Mounting Ring** – eliminates the need for sloping concrete to reduce snow-plow and traffic hazards
- ◆ **Highway 20 Rated (H20/HS20)** – all OPW spill-containers and manholes exceed the requirements of the Highway 20 rating

Ordering Specifications

Product #	ID (in.)	ID (mm)	lbs.	kg
104C-2000	20	500	22	10.0

Replacement Parts

Part #	Description
101BG-Cover	Cover for 104C-2000

Dimensions

Product #	A		B		C	
	in.	cm	in.	cm	in.	cm
104C-2000	19	48.26	20 ³ / ₄	52.7	11	27.9

Typical Underground Storage Tank Manhole Layout

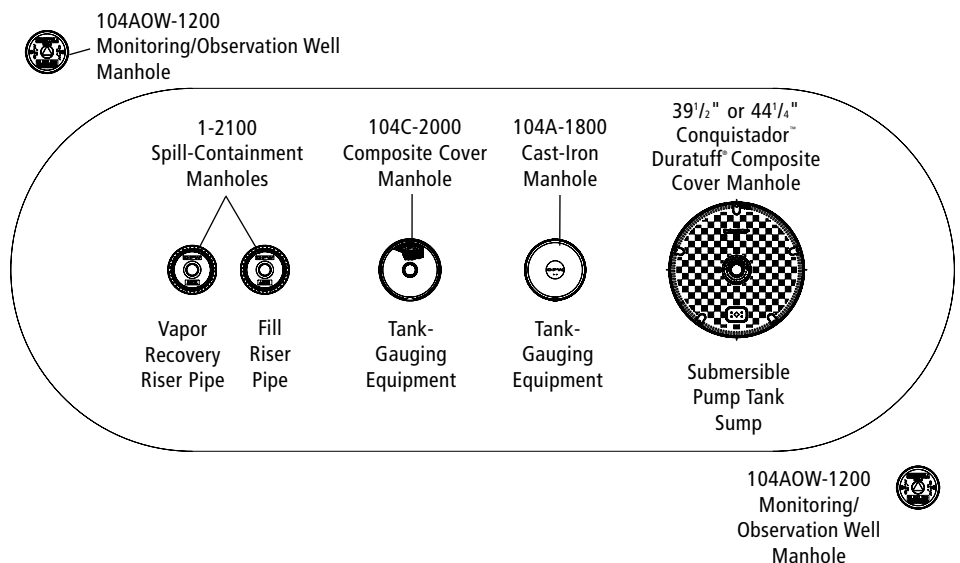

Materials

- Body Ring:** Cast iron
- Cover:** Cast iron
- Skirt:** Galvanized steel



OPW 104 Series Cast-Iron Manholes

Heavily ribbed cast-iron covers and body rings ensure maximum load-bearing capacity on cast-iron manholes and fill boxes. These manholes are ideal for connecting underground tank lines directly to the surface without sump enclosures. A variety of features available on cast-iron manholes and fill boxes make them the perfect choice for many applications.

OPW 104A Cast-Iron Manhole

A sturdy steel skirt on the standard 104A extends nearly a foot below grade to ensure trouble-free installation in deep concrete, and optional skirts that extend a full 19-1/4" below grade are available in 12" and 18" diameters for sandy-soil locations.

OPW 104FG Cast-Iron Manhole

The 104FG provides a convenient finger-grip feature on the cover to facilitate cover removal.

Features

- ◆ Full-size internal diameters for maximum access and working area
- ◆ Highway 20 Rated (H20/HS20) – All OPW spill-containers and manholes exceed the requirements of the Highway 20 rating
- ◆ Rugged cast-iron covers and body rings
- ◆ Cast-in, non-skid finish on covers
- ◆ Sturdy, extra-long steel skirts
- ◆ Individually boxed for ease of handling

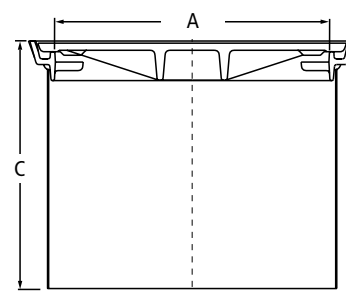

OPW 104A/FG Cast-Iron Cover Manholes

Ordering Specifications

Product #	ID (in.)	ID (mm)	lbs.	kg
104A-0800	8	203	15	6.8
104A-0800WT (bolt down)	8	203	15	6.8
104A-1200	12	305	28	12.7
104A-1200WT (bolt down)	12	305	33	15.0
104A-1219	12	305	33	15.0
104FG-1200*	12	305	28	12.7
104FG-1219*	12	305	33	15.0
104A-1800	18	457	50	22.7
104A-1800WT (bolt down)	18	457	50	22.7
104A-1819	18	457	57	25.9
104A-1819WT (bolt down)	18	457	57	25.9

* Finger Grip Cover Manhole

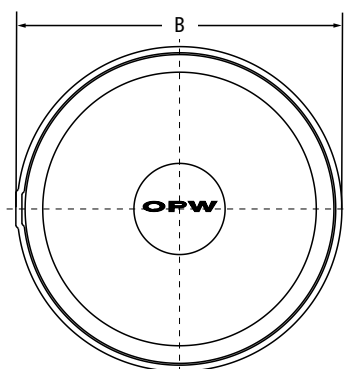

OPW 104A & 104FG Cover

Replacement Parts

Part #	Description
E00508M	Cover for 8" 104A-0800
E00510M	Cover for 12" 104A-1200
E00584M	Cover for 12" 104FG-1200
E00512M	Cover for 18" 104A-1800
206118	Cover for 8" 104A-0800WT
206119	Cover for 12" 104A-1200WT
206120	Cover for 18" 104A-1800WT

Replacement Parts

Part #	Description
H12872M	Seal for 8" Ring
H12873M	Seal for 12" Ring
H12874M	Seal for 18" Ring

Dimensions

Product #	A		B		C	
	in	cm	in	cm	in	cm
104A-0800	8	20.3	10 ¹ / ₈	25.7	11 ¹ / ₄	28.6
104A/FG-1200	12	30.5	14 ¹ / ₄	36.2	11 ¹ / ₄	28.6
104A/FG-1219	12	30.5	14 ¹ / ₄	36.2	19 ¹ / ₄	48.9
104A-1800	18	45.7	20 ¹ / ₈	51.1	11 ¹ / ₄	28.6
104A-1819	18	45.7	20 ¹ / ₈	51.1	19 ¹ / ₄	48.9

OPW 110/120 Series Steel Round Manholes

OPW 110/120 Series Round Manholes are designed for use in a wide range of service station driveway, industrial and commercial applications. The 110s and 120s are used to provide access to all types of underground equipment, including vapor recovery connections, UST-monitoring equipment and submersible pumps. The 120 Series includes Roto-Lock fasteners on 24" and larger manholes.

Features

- ◆ **Standard and Rain-tight Models Available** – models include Buna-N gaskets and recessed hex-head bolts or Roto-Lock fasteners to help prevent water intrusion
- ◆ **Wide Range of Sizes** – sizes range from 24" to 48" (61 to 122 cm) to accommodate a wide range of applications. Custom sizes and configurations are also available
- ◆ **Easy Cover Removal** – an integral recessed handle is included on all

Materials

Skirt: Galvanized steel
Cover: Steel diamond plate
Ring: Cast iron or fabricated steel
Gasket: Nitrile

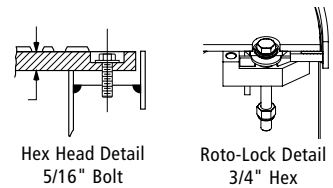
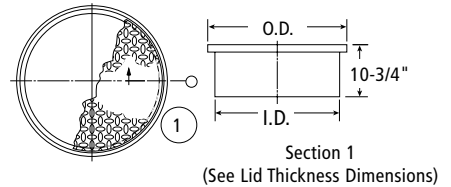

rain-tight and plain manholes 24" and larger. Manholes 42" and larger include dual recessed handles and provisions for a centered 1/2" - 13-threaded Allen-head blind plug for easy removal so that a 1/2" - 13 eyebolt can be threaded into the hole for easier removal of covers

- ◆ **Highway 20 Rated (H20/HS20)** – all OPW spill-containers and manholes exceed the requirements of the Highway 20 rating

Ordering Specifications

Model #	Description	Cover O.D.		Skirt I.D.		Thickness		Weight		Ring
		in.	cm	in.	cm	in.	cm	lbs.	kg	
6110-24WT	Rain-tight*	24	61	21 ⁵ / ₈	55	³ / ₈	.9	88	40	Fab. Steel
6110-2410	Standard*	24	61	21 ⁵ / ₈	55	³ / ₈	.9	88	40	Fab. Steel
6110-30WT	Rain-tight*	30	76	27 ⁵ / ₈	70	1/2	1.3	160	73	Fab. Steel
6110-3010	Standard*	30	76	27 ⁵ / ₈	70	³ / ₈	.9	160	73	Fab. Steel
6110-37WT	Rain-tight*	37	94	34 ⁵ / ₈	88	1/2	1.3	178	81	Fab. Steel
6110-3710	Standard*	37	94	34 ⁵ / ₈	88	³ / ₈ **	.9	178	81	Fab. Steel
6110-4010	Standard*	40	102	37 ⁵ / ₈	96	³ / ₈	.9	198	90	Fab. Steel
6110-42WT	Rain-tight*	42	107	39 ⁵ / ₈	101	1/2**	1.3	290	132	Fab. Steel
6110-4200	Standard	42	107	39 ⁵ / ₈	101	1/2**	1.3	290	132	Fab. Steel
6110-48WT	Rain-tight*	48	122	45 ⁵ / ₈	116	1/2**	1.3	390	177	Fab. Steel
6110-42WT18	Rain-tight with 18" skirt*	42	107	39 ⁵ / ₈	101	1/2**	1.3	290	132	Fab. Steel
6120-24WT	Roto-Lock Rain-tight 24WT*	24	61	22 ⁵ / ₈	58	³ / ₈	.9	88	40	Fab. Steel
6120-30WT	Roto-Lock Rain-tight 30WT*	30	76	28 ⁵ / ₈	72	1/2	1.3	160	73	Fab. Steel
6120-37WT	Roto-Lock Rain-tight 37WT*	37	94	35 ⁵ / ₈	91	³ / ₈	1.3	178	81	Fab. Steel
6120-42WT	Roto-Lock Rain-tight 42WT*	42	107	40 ⁵ / ₈	103	1/2**	1.3	290	132	Fab. Steel
6120-48WT	Roto-Lock Rain-tight 48WT*	48	122	46 ⁵ / ₈	118	1/2**	1.3	390	177	Fab. Steel

* Recessed Handle
 ** Reinforced Cover

Standard - Plain No Bolts
 Rain-tight - Bolt Down
 Deep skirts available upon request

Replacement Parts

Part #	Description
P110-8G	8" Replacement Gasket
P110-12G	12" Replacement Gasket
P110-16G	16" Replacement Gasket
P110-18G	18" Replacement Gasket
P110-24G	24" Replacement Gasket
P110-30G	30" Replacement Gasket
P110-37G	37" Replacement Gasket
P110-40G	40" Replacement Gasket
P110-42G	42" Replacement Gasket
P110-48G	48" Replacement Gasket
PROTO-LOCK	(1) Replacement Roto-Lock
P110-8L	Replacement Cover 8"
P110-12L	Replacement Cover 12"
P110-16L	Replacement Cover 16"
P110-18L	Replacement Cover 18"
P110-24L	Replacement Cover 24"
P110-30L	Replacement Cover 30"
P110-37L	Replacement Cover 37"
P110-40L	Replacement Cover 40"
P110-42L	Replacement Cover 42"
P110-48L	Replacement Cover 48"
P110-18WT	Replacement Cover 18" Bolt Down
P110-24WLT	Replacement Cover 24" Bolt Down
P110-30WLT	Replacement Cover 30" Bolt Down
P110-37WLT	Replacement Cover 37" Bolt Down
P110-42WLT	Replacement Cover 42" Bolt Down
P110-48WLT	Replacement Cover 48" Bolt Down
P120-37L	Replacement Cover 37" Roto-Lock
P120-42L	Replacement Cover 42" Roto-Lock
RPHK	Replacement Handle

Materials:

Cover: Fiberglass
Frame: Fiberglass
Skirt: Fiberglass

Cover Includes Frame
 and Skirt

Monitoring Well Manholes



Features & Benefits:

- ◆ UV resistant
- ◆ Round, square and rectangular (wide range of sizes)
- ◆ Anti-slip surface – no costly injury claims
- ◆ Will not corrode
- ◆ Watertight, sealed design
- ◆ No bolts required
- ◆ Ergonomic, single-person removal and replacement with Fibrelite lifting handle

Ordering Specifications - Monitoring Well Manholes

Part #	Description	Color	Skirt I.D.	Cover O.D.	Skirt Length	Wt.
FL120BLACK-MW	Flat Sealed Composite Cover - Labeled	Black	12"	15"	3.91"	13 lbs
FL120BLACK-MW-SK12	Bonded	Black	12"	15"	12"	26 lbs

Bonded - Assembled Cover, Ring And Skirt

Fibrelite Composite Monitoring Manholes

Fibrelite offers the retail-petroleum industry's leading watertight, easy to remove, non-bolted composite manhole covers in a large selection of shapes and sizes. From general tank-sump access to multiport and single-port fill-sump applications to interstitial sumps and monitoring-wells, Fibrelite has every application covered.

Multiple colors are available – Contact OPW Customer Service for pricing, availability, and lead times.

Replacement Covers

FL120BLACK-MW

Sealed - Labeled Monitoring Well Cover

Color	Skirt I.D.	Cover O.D.	Cover Ht.	Wt.
Black	12"	15"	3.91"	13 lbs

OPW Monitoring/Observation Well Manholes

Designed to be installed at grade-level over a slotted PVC monitoring-well where limited access and clear identification are essential. Ring gasket prevents water contamination.

Materials

Body Ring: Cast iron
Cover: Cast iron
Skirt: Steel (104 AOW)
Gasket: Neoprene

104AOW-1200

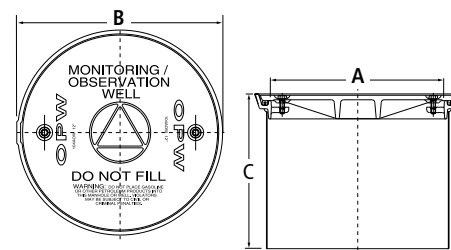

Ordering Specifications

Product #	ID (in.)	ID (mm)	lbs.	kg
104AOW-0800	8	203	15	6.8
104AOW-1200	12	305	28	12.7
104AOW-1219	12	305	33	15.0
104AOW-1800	18	457	50	22.7
104AOW-1819	18	457	57	25.9

Replacement Parts

Part #	Description
E00514I	Cover for 8" 104AOW-0800
E00515I	Cover for 12" 104AOW-1200
E00514I	Cover for 8" 104MW-0800
E00516I	Cover for 18" 104AOW-1800
H12872M	Gasket for 104AOW 8"
H12873M	Gasket for 104AOW 12"
H12874M	Gasket for 104AOW 18"

Dimensions

Product #	A		B		C	
	in.	mm	in.	mm	in.	mm
104AOW-0800	8	203	10 ¹ / ₈	257	11 ¹ / ₄	286
104AOW-1200	12	305	14 ¹ / ₄	362	11 ¹ / ₄	286
104AOW-1219	12	305	14 ¹ / ₄	362	19 ¹ / ₄	489
104AOW-1800	18	457	20 ¹ / ₈	511	11 ¹ / ₄	286
104AOW-1819	18	457	20 ¹ / ₈	511	19 ¹ / ₄	489



Brine-Monitoring Reservoir

Deep solid-base sump, with a spill-container, integrated drainback system to the tank

Ordering Specifications

Part #	Description	Weight (lbs)
S45-1180BL	18" dia. x 18" DP FRP Sump w/ FL180F & FL180BLACK Cover	76
S45-1180G	18" dia. x 18" DP FRP Sump w/ FL180F & FL180GRAY Cover	76



Replacement Manhole Covers (Old & New)

Product #	Replacement Cover	Cover O.D.
104A-1066	D00173M	13 ¹ / ₈ "
104A-0800	E00508M	9 ¹ / ₂ "
104A-1200 & 1219	E00510M	13 ¹ / ₂ "
104A-1800 & 1819	E00512M	19 ¹ / ₂ "
104AOW-0800	E00514M	9 ¹ / ₂ "
104AOW-1200 & 1219	E00515I	13 ¹ / ₂ "
104AOW-1800 & 1819	E00516I	19 ¹ / ₂ "

Aboveground Products

Setting the Industry Standard for More Than 120 Years

Conventional Automatic Nozzles

- Automatic Nozzles 141 - 157
- Extreme Cold-Weather Nozzles 148
- Custom Hand Insulator Imprinting 149
- OPW AdMaster™ 149
- Factory-Assembled Hose Kits 150
- 11AF® 3/4" Automatic Nozzles 151
- Heavy-Duty, High-Flow Truck, Bus & Fleet Nozzles 152 - 153
- OPW NEWGARD™ Hand Insulators 154
- 21Gu™ DEF Nozzle 155 - 157

Swivels and Breakaways

- Swivels and Breakaways 159 - 166
- Flow Limiters 167

Vacuum-Assist Swivels and Breakaways

- 12VW Vacuum-Assist Nozzle 169 - 170
- Vacuum-Assist Swivels, Breakaways and Accessories 171 - 172

Balance Vapor Recovery Hanging Hardware

- Balance Breakaways & Accessories 176

Industrial Products

- DEF Bulk Nozzle 178
- Automatic Bulk-Fueling & Aircraft Nozzles 179 - 183
- Manual High-Flow Bulk-Fill Nozzles 184 - 188
- Manual Nozzle Accessories 189
- Manual Utility Farm Nozzle 190
- Swivels and Breakaways 191 - 192

Retractors

- Spring-Balance Hose Retractors 193 - 196
- Counterweight Hose Retractors (MPD) 197

OPW AUTOMATIC NOZZLE FEATURES – MULTIPLE SOLUTIONS FOR MULTIPLE CUSTOMERS

The diagram shows a detailed view of an OPW automatic nozzle. Red lines connect various parts of the nozzle to callout boxes, each describing a specific feature and its benefits.

- No-Pressure No-Flow Device**
 - ◆ Safety feature to prevent spills when system is not pressurized
- Accu-Stop™ Flow Control**
 - ◆ Allows customer to top off tank to exact amounts
 - ◆ Easily stops the flow of gasoline precisely
- Durable Spout**
 - ◆ Highest flow rates in industry
 - ◆ Quick/easy replacement
 - ◆ Stainless-steel tip (11B only)
- Automatic Shut-Off Sensing Port**
 - ◆ Highly accurate sensing port ensures nozzle shut off reliability
- Flow Lock™**
 - ◆ Shuts off nozzle automatically when spout is tipped up, limiting spillage
- Hand Insulator**
 - ◆ Attractive visual appeal
 - ◆ Comfortable to the touch in cold or hot weather
 - ◆ Ergonomic for smaller hands
 - ◆ Available in a variety of colors
- Low-Profile Aluminum Body**
 - ◆ Lightweight and durable
 - ◆ Attractive design
- Duratuff® Lever & Guard**
 - ◆ Toughest, most durable handguard & lever in the industry
 - ◆ Comfortable to the touch in hot or cold weather
- Blocker on the Lever Guard**
 - ◆ Prevents use of foreign objects to jam nozzle open in pre-pay applications
- Trigger Spring**
 - ◆ Great durability & service life
 - ◆ Improves clip disengagement at shut off
- Hold-Open Rack**
 - ◆ Easy, one-finger control to set flow rate

OPW CARB-Certified 14E ECO Enhanced Conventional Gasoline Nozzle

The OPW 14E ECO Enhanced Conventional Gasoline Nozzle is part of the new OPW 14 Series cleaner fueling experience nozzles, featuring innovative patented* driplless free-draining spout technology. Other driplless technologies capture fuel in the spout where it is allowed to evaporate and increase VOC emissions.

The new OPW 14E driplless-spout technology is designed to keep gasoline from dripping on your customers' hands, clothing, vehicles and the ground to provide a cleaner, greener, and more satisfying customer experience.

The CARB ECO OPW 14E utilizes a special interlock system inside the bellows to activate the flow of fuel.

CARB exec order in Listings and Certifications section of this catalog.

Driplless Nozzle Technology

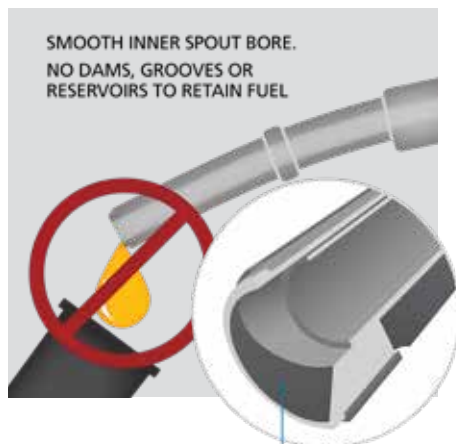
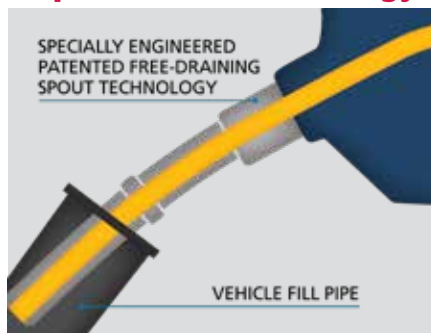

UNIQUE SPOUT DESIGN PREVENTS FUEL DRIPS ONCE THE NOZZLE AUTOMATIC SHUTOFF FEATURE IS ACTIVATED

MATERIALS

- Body:** Aluminum
- Lever & Lever Guard:** Duratuff®
- Packing:** Graphite with Teflon®
- Disc:** Viton®
- Spout:** Aluminum with Stainless-Steel tip and Teflon®-coated inside
- Inlet Size:** 3/4" NPT
- Weight:** 2.73 lbs. each
1.25 kg each



FEATURES & BENEFITS

Safe for Use

- ◆ True Driplless Technology* – patented driplless, free-draining spout with no dams or hidden reservoirs to catch liquid. Designed to exceed CARB driplless requirements.
- ◆ Rugged Durability – designed to meet the rigorous demands of high-volume sites.
- ◆ FlowLock™ allows nozzle to shut off when falling out of a vehicle or is tipped up, limiting spillage and unsafe conditions.
- ◆ Enhanced Drip Control (14E Models only) - specially designed interlock prevents fuel from flowing unless the spout is fully inserted in the vehicle fill pipe and the actuator is engaged. This is a CARB requirement.

Durable and Long-Lasting Design

- ◆ Cycle tested and proven to last longer than 1 million cycles.

- ◆ Durable lever guard that won't scratch your customers' vehicles – made from Duratuff®.

Cleaner Fueling Experience for Customers

- ◆ Easy to use – utilizing Accu-Stop® to-the-penny Flow Control Technology.
- ◆ Attractive two-piece hand-insulator which includes NEWGARD™ barrel cover and colored scuff guard, is the most comfortable nozzle in the industry to use.
- ◆ Convenient – one-finger hold-open clip that is easy to set the flow rate.

Design Working Pressure

- ◆ 50 psi (3.45 bar) maximum pressure.

LISTINGS & CERTIFICATIONS



*US PATENTS 7,134,580 AND 9,126,820. OTHER PATENTS-PENDING

ORDERING SPECIFICATIONS

Scuff Guard Color	14E Unleaded Nozzles
Green	14E-0100
Red	14E-0300
Black	14E-0400
Blue	14E-0500
Yellow	14E-0900
14E Replacement Kit	5BE-0100

Contact customer service for hose-assembly kits.

GPM FLOW CHART

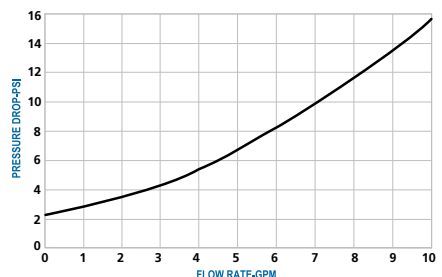

OPW 14BP Gasoline Nozzle

The OPW 14BP Conventional Gasoline Nozzle is part of the new OPW 14 Series cleaner fueling experience nozzles, featuring innovative patented and patent-pending dripless-spout technology.

The new OPW 14BP dripless nozzle spout technology is designed to keep gasoline from dripping on your customers' hands, clothing, vehicles and the ground to provide a cleaner, greener and more satisfying customer experience.

The OPW 14BP is a standard fueling nozzle without the interlock device.

Dripless Nozzle Technology

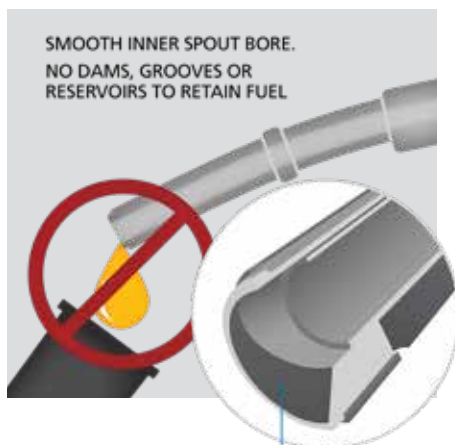
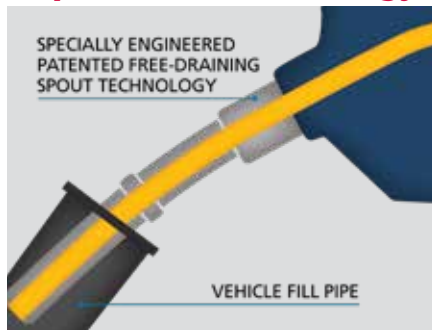

UNIQUE SPOUT DESIGN PREVENTS FUEL DRIPS ONCE THE NOZZLE AUTOMATIC SHUTOFF FEATURE IS ACTIVATED

MATERIALS

- Body:** Aluminum
- Lever & Lever Guard:** Duratuff®
- Packing:** Graphite with Teflon®
- Disc:** Viton®
- Spout:** Aluminum with Stainless-Steel tip and Teflon®-coated inside
- Inlet Size:** 3/4" NPT
- Weight:** 2.73 lbs. each
1.25 kg each



FEATURES & BENEFITS

Safe for Use

- ◆ True Dripless Technology* – patented and patent-pending, dripless-spout, no dams or hidden reservoirs to catch liquid. Designed to exceed CARB dripless requirements.
- ◆ Rugged Durability – designed to meet the rigorous demands of high-volume sites.
- ◆ FlowLock™ allows nozzle to shut off when falling out of a vehicle or is tipped up, limiting spillage and unsafe conditions.

Durable and Long-Lasting Design

- ◆ Cycle tested and proven to last longer than 1 million cycles.
- ◆ Durable lever guard that won't scratch your customers' vehicles – made from Duratuff®.

Cleaner Fueling Experience for Customers

- ◆ Easy to use – utilizing Accu-Stop® to-the-penny Flow Control Technology.
- ◆ Attractive two-piece NEWGARD™ Hand Insulator is the most comfortable nozzle in the industry to use.
- ◆ Convenient – one-finger hold-open clip that is easy to set the flow rate.

Design Working Pressure

- ◆ 50 psi (3.45 bar) maximum pressure.

LISTINGS & CERTIFICATIONS



*US PATENTS 7,134,580 AND 9,126,820. OTHER PATENTS-PENDING

ORDERING SPECIFICATIONS

2-Piece Hand Insulator Color	14BP Unleaded
Green	14BP-0100
Red	14BP-0300
Black	14BP-0400
Blue	14BP-0500
Yellow	14BP-0900

Contact customer service for hose-assembly kits.

GPM FLOW CHART

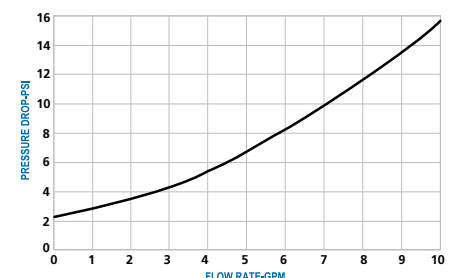

OPW 14C Diesel-Capture Technology Nozzle

The OPW 14C is part of the new OPW 14 Series cleaner fueling experience nozzles, featuring innovative patented* diesel-capture technology. This innovation is designed to provide a cleaner, greener fueling experience for customers while keeping diesel fuel off their hands and off the ground.

Diesel-Capture Technology

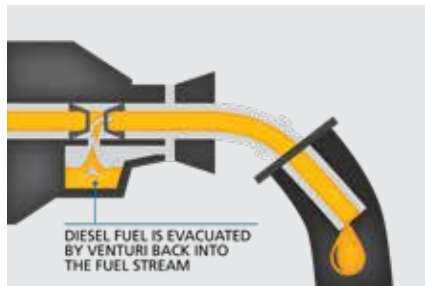
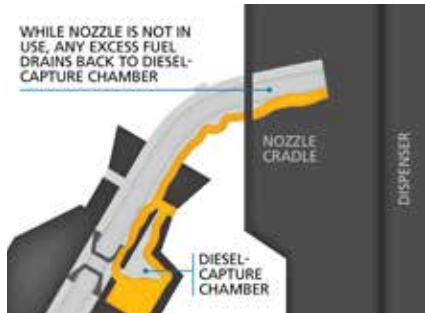
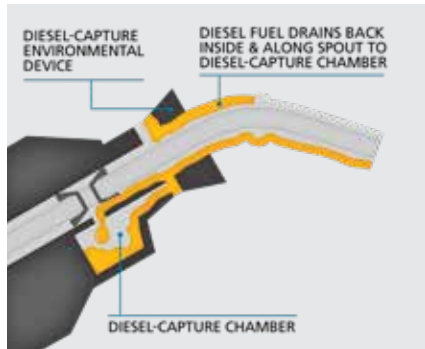
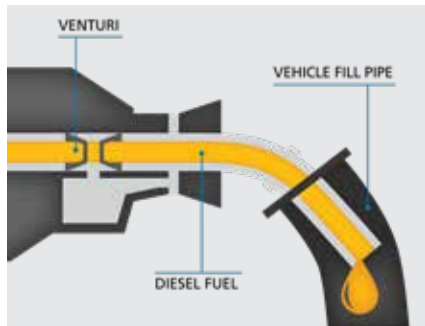

MATERIALS

- Body:** Aluminum
- Lever & Lever Guard:** Duratuff®
- Packing:** Graphite with Teflon®
- Disc:** Viton®
- Spout:** Aluminum
- Inlet Size:** 3/4" NPT
- Weight:** 2.73 lbs. each
1.25 kg each



FEATURES & BENEFITS

Safe for Use

- ◆ Diesel-Capture Technology* – the patented technology allows excess diesel fuel to drain into a uniquely engineered chamber located in the body of the nozzle located at the base of the spout. This excess diesel fuel is then introduced back into the fuel stream.
- ◆ Drip Guard – designed to capture any fuel that runs out onto the outside of the nozzle.
- ◆ Compatible for diesel-fuel blends up to B20.
- ◆ Rugged Durability – designed to meet the rigorous demands of high-volume sites.
- ◆ FlowLock™ allows nozzle to shut off when falling out of a vehicle or is tipped up, limiting spillage and unsafe conditions.

Durable and Long-Lasting Design

- ◆ Cycle tested and proven to last longer than 1 million cycles.

- ◆ Durable lever guard that won't scratch your customers' vehicles – made from Duratuff®.

Cleaner Fueling Experience for the Customer

- ◆ Easy to use – utilizing Accu-Stop® to-the-penny Flow Control Technology.
- ◆ Attractive two-piece hand-insulator which includes NEWGARD™ barrel cover and colored scuff guard, is the most comfortable nozzle in the industry to use.
- ◆ Convenient – one-finger hold-open clip that is easy to set the flow rate.

Design Working Pressure

- ◆ 50 psi (3.45 bar) maximum pressure.

LISTINGS & CERTIFICATIONS



*US PATENTS 7,134,580 AND 9,126,820.
OTHER PATENTS-PENDING

ORDERING SPECIFICATIONS

Scuff Guard Color	14C Diesel Nozzles
Green	14C-0100
Red	14C-0300
Black	14C-0400
Blue	14C-0500
Yellow	14C-0900

GPM FLOW CHART

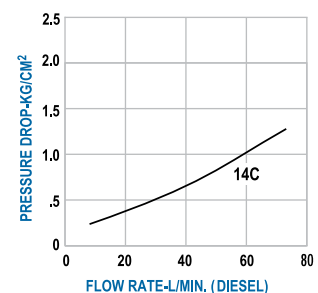

OPW 14HC Hi-Flo Diesel-Capture Technology Nozzle

The OPW 14HC Hi-Flo is part of the new OPW 14 Series cleaner fueling experience nozzles, featuring innovative patented* diesel-capture technology. This innovation is designed to provide a cleaner, greener fueling experience for retail and commercial high-speed truck-stop lanes.

Diesel-Capture Technology

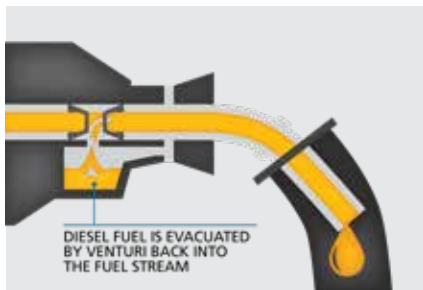
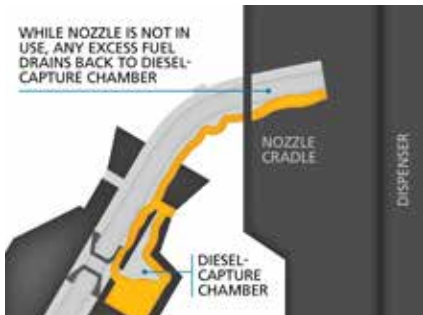
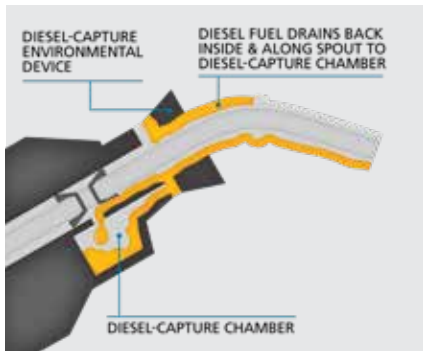
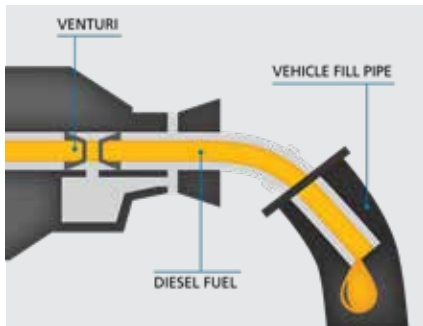

MATERIALS

- Body:** Aluminum
- Lever & Lever Guard:** Duratuff®
- Packing:** Graphite with Teflon®
- Disc:** Viton®
- Spout:** Aluminum
- Inlet Size:** 1" NPT
- Weight:** 2.73 lbs. each
1.25 kgs. each



FEATURES & BENEFITS

Safe for Use

- ◆ Diesel-Capture Technology* – the patented technology allows excess diesel fuel to drain into a uniquely engineered chamber located in the body of the nozzle located at the base of the spout. This excess diesel fuel is then introduced back into the fuel stream.
- ◆ Drip Guard – designed to capture any fuel that runs out onto the outside of the nozzle.
- ◆ Compatible for diesel-fuel blends up to B20.
- ◆ Rugged Durability – designed to meet the rigorous demands of high-volume sites.
- ◆ FlowLock™ allows nozzle to shut off when falling out of a vehicle or is tipped up, limiting spillage and unsafe conditions.

Durable and Long-Lasting Design

- ◆ Cycle tested and proven to last longer than 1 million cycles.
- ◆ Durable lever guard that won't scratch your customers' vehicles – made from Duratuff®.

Cleaner Fueling Experience for the Customer

- ◆ Easy to use – utilizing Accu-Stop® to-the-penny Flow Control Technology.
- ◆ Attractive two-piece hand-insulator which includes NEWGARD™ barrel cover and colored scuff guard, is the most comfortable nozzle in the industry to use..
- ◆ Convenient – one-finger hold-open clip that is easy to set the flow rate.

Design Working Pressure

- ◆ 50 psi (3.45 bar) maximum pressure.

ORDERING SPECIFICATIONS

B-20 Nozzles compatible up to B20 (20% Biodiesel)

Hand Warmer Color	14HC 1" Truck	14HC Extreme Cold 1" Truck	14HC Canada Nozzle, Extreme Cold, NoText
Green	14HC-0100	14HC-0100-XC	14HC-0100NC-XC
Black	14HC-0400	14HC-0400-XC	14HC-0400NC-XC
Yellow	14HC-0900	14HC-0900-XC	14HC-0900NC-XC

Listings and Certifications

*US PATENTS 7,134,580 AND 9,126,820.
OTHER PATENTS-PENDING

GPM FLOW CHART

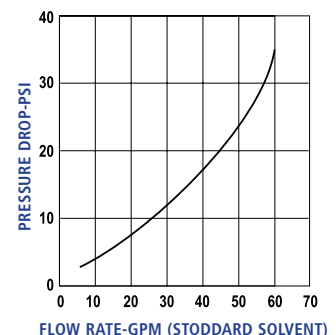

OPW 11A® and 11B® Automatic Nozzles

The OPW 11® Series Automatic Nozzles are OPW's premium conventional nozzles for safe retail and commercial petroleum filling. The OPW 11® Series is the most trusted conventional nozzle in the world for full-service use. The OPW 11B® Series is designed for use in retail and commercial filling applications including prepay, self- and full-service, credit/debit card readers or card-lock systems to help prevent gasoline spills. The OPW 11B® will not open until the pumping system is pressurized, and closes automatically when the pressure is removed.

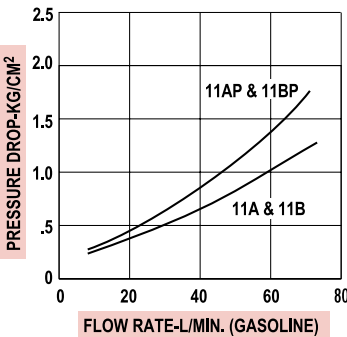
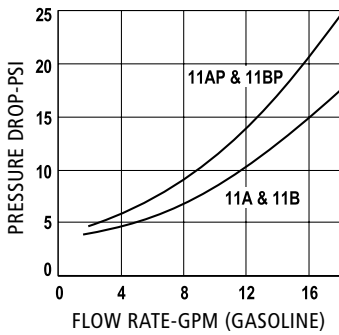

Replacement Parts

Name	Product #	Description	Used For:
11A Leaded Spout Kit	5BS-2110	11A, 15/16" O.D. Leaded Spout	11A Spout Replacement
11AP Unleaded Spout Kit	5BPS-2117	11AP, 13/16" O.D. Unleaded Spout	11AP Spout Replacement
11B Leaded Spout Kit	5BBS-2135	11B, 15/16" O.D. Leaded Spout	11B Spout Replacement
11BP Unleaded Spout Kit	5BBPS-2137	11BP, 13/16" O.D. Unleaded Spout	11BP Spout Replacement
NEWGARD Kits	See pg. 154	Replacement Hand Insulators	11A, 11AP, 11B, 11BP NEWGARD Replacements
Instruction Sheet	H15985M	Installation and Instruction Sheet	11A, 11AP, 11B, 11BP Instruction Sheet

Materials

- Body:** Aluminum
- Lever & Lever Guard:** Duratuff®
- Packing:** Graphite with Teflon®
- Disc:** Viton®
- Spout:** Aluminum
- Inlet Size:** 3/4" NPT
- Weight:** 2.73 lbs. each, 43.1 lbs./case of 15
1.25 kg each, 19.9 kg/case of 15

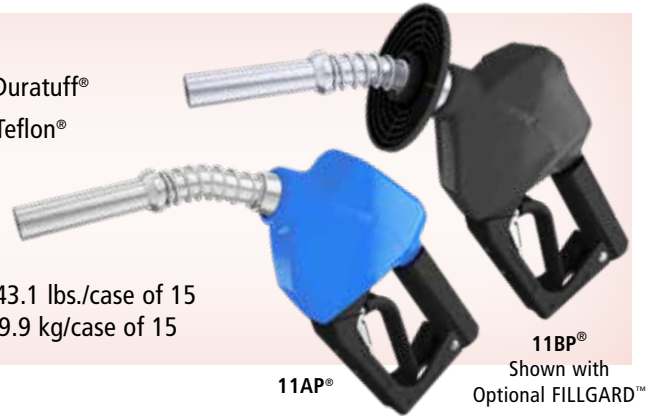

Features

Safe for Use

- ◆ UL- and ULc-Listed for use in gasoline, diesel, and up to 10% ethanol blends. Specific listings available at www.opwglobal.com.
- ◆ Prevents gasoline spills in prepay or card-lock systems utilizing OPW's unique No-Pressure - No-Flow Device. The nozzle cannot be opened until the pumping system is pressurized, and closes automatically when the pressure is removed (11B Series only).
- ◆ Prevents consumer from jamming the nozzle in an open position – blocker on lever guard.
- ◆ FlowLock™ allows nozzle to shut off when falling out of a vehicle and is tipped up, limiting spillage and unsafe conditions.

Durable and Long-Lasting Design

- ◆ Cycle-tested and proven to last longer than 1 million cycles – better than any other nozzle available on the market today.

- ◆ Durable lever guard that won't scratch your customers' vehicles – made from Duratuff®.
- ◆ New hold-open clip spring lasts longer than previous designs.

Appealing to Customers

- ◆ Easy to use – utilizing Accu-Stop® to-the-penny Flow Control Technology.
- ◆ Attractive 2-Piece NEWGARD™ Hand Insulator is the most comfortable nozzle in the industry to use.
- ◆ Convenient – one-finger hold-open clip that is easy to set the flow rate (not on all models).

Design working pressure

- ◆ 50 psi (3.45 bar) maximum pressure.



285-0350
Bushing Adaptor



28R-2404
Bushing Adaptor

Accessories

Name	Product #	Description	Used For:
3/4" to 1" Bushing	285-0350	3/4" MNPT to 1" FNPT Bushing	Converting 11 Series Nozzle for use on 1" Hose
1" to 3/4" Bushing	28R-2404	1" MNPT x 3/4" FNPT Bushing	Converting 7 Series Nozzle for use on 3/4" Hose

Listings and Certifications



See pages XXX - XX for certification number

Materials

- Body:** Aluminum w/nickel plating
- Lever & Lever Guard:** Duratuff®
- Packing:** Graphite with Teflon®
- Seals:** Viton®
- Spout:** Aluminum w/ nickel plating
- Inlet Size:** 3/4" NPT
- Weight:** 2.73 lbs. each
1.25 kg each



11BP-0992-E85

Features

Safe for Use

- ◆ UL-Listed for up to 85% Ethanol.
- ◆ Prevents gasoline spills in prepay or card-lock systems utilizing OPW's unique No-Pressure - No-Flow Device. It cannot be opened until the pumping system is pressurized, and closes automatically when the pressure is removed.
- ◆ Prevents consumer from jamming the nozzle in an open position – blocker on lever guard.
- ◆ FlowLock™ allows nozzle to shut off when falling out of a vehicle, and is tipped up, limiting spillage and unsafe conditions.

Durable and Long Lasting Design

- ◆ Cycle-tested and proven to last longer than 1 million cycles – Better than any other nozzle available on the market today.

- ◆ Durable lever guard that won't scratch your customers' vehicles – made from Duratuff®.
- ◆ New hold-open clip spring lasts longer than previous designs.

Appealing to Customers

- ◆ Easy to use – utilizing Accu-Stop® to-the-penny Flow Control Technology.
- ◆ Attractive 2-Piece NEWGARD™ Hand Insulator is the most comfortable nozzle in the industry to use.
- ◆ Convenient – one-finger hold-open clip that is easy to set the flow rate (not on all models).

Design working pressure

- ◆ 50 psi (3.45 bar) maximum pressure.

Ordering Specifications

E-85 Nozzles compatible up to E85 (85% Ethanol)

Handwarmer Color	11BP Unleaded 2 Piece Handwarmer
■ Green	11BP-0192-E85
■ Red	11BP-0392-E85
■ Black	11BP-0492-E85
■ Yellow	11BP-0992-E85

241TPS Ordering Specifications E85-Approved

Product #	Inlet/Outlet	Length A	Depth B
241TPS-0492	3/4" F x 3/4" M (NPT) 19 mm x 19 mm	4 7/8" 124 mm	2 7/16" 56 mm

OPW 11BP E-85 Series Ethanol Nozzles

The OPW 11BP E-85 Series nozzles are designed and rigorously tested for use with today's alternative fuels. It's the first nozzle of its kind to be UL-Listed for use in Ethanol-blended fuels up to 85%.

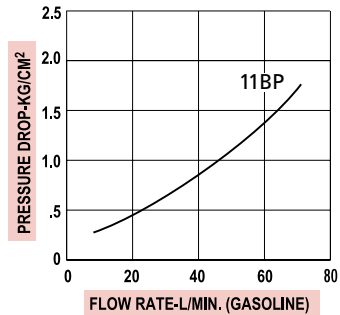
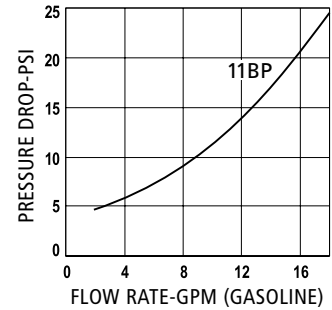

Listings and Certifications



UL-Listed for up to 85% Ethanol

Replacement Parts

Product	Product #	O.D.	Length	Weight
		in. mm	in. mm	lbs. kg
11BP spout replacement kit	5BBPI-0492	13/16" 21	7" 178	.47 .22

NEWGARD™ Kits See page 154.
11BP Instruction Sheet Order Number: H15889PAE

66V Ordering Specifications E85-Approved

Product #	Size	Weight	Pull Force
	in. mm	lbs. kg	
66V-0492	3/4" F x 3/4" F (NPT) 19 F x 19 F	0.60 0.27	300 lbs.

66V Series 3/4" Instruction Sheet Order Number: H10993PA

Ordering Specifications

E-10 Automatic Nozzles compatible up to E10 (10% Ethanol)

Handwarmer Color	11AP Unleaded* 2 Piece Handwarmer without Hold-Open Devices	11BP Unleaded 2 Piece Handwarmer with Hold-Open Devices
Green	11AP-0100	11BP-0100
Silver	11AP-0200	11BP-0200
Red	11AP-0300	11BP-0300
Black	11AP-0400	11BP-0400
Blue	11AP-0500	11BP-0500
Gold	11AP-0750	11BP-0750
Orange	11AP-0800	11BP-0800
Yellow	11AP-0900	11BP-0900
Bare	11AP-0009	11BP-0009

*11A Nozzles are no longer permitted and sold with Hold-Open Clips per UL-2586 requirements.

E-25 Nozzles compatible up to E25 (25% Ethanol)

Handwarmer Color	11AP* Unleaded 2 Piece Handwarmer	11BP Unleaded 2 Piece Handwarmer
Green	11AP-0100-E25	11BP-0100-E25
Red	11AP-0300-E25	11BP-0300-E25
Black	11AP-0400-E25	11BP-0400-E25
Blue	11AP-0500-E25	11BP-0500-E25
Orange	11AP-0800-E25	11BP-0800-E25
Yellow	11AP-0900-E25	11BP-0900-E25

*11A Nozzles are no longer permitted and sold with Hold-Open Clips per UL-2586 requirements.

E-85 Nozzles compatible up to E85 (85% Ethanol)

Handwarmer Color	11BP Unleaded 2 Piece Handwarmer
Green	11BP-0192-E85
Red	11BP-0392-E85
Black	11BP-0492-E85
Yellow	11BP-0992-E85

B-5 Nozzles compatible up to B5 (5% Biodiesel), Fuel Oil and Kerosene

Handwarmer Color	11A Leaded* 2 Piece Handwarmer	11B Leaded 2 Piece Handwarmer
Green	11A-0100	11B-0100
Silver	11A-0200	-
Red	11A-0300	11B-0300
Black	11A-0400	11B-0400
Blue	11A-0500	11B-0500
Gold	11A-0750	11B-0750
Orange	11A-0800	11B-0800
Yellow	11A-0900	11B-0900
Bare	11A-0009	11B-0009

*11A Nozzles are no longer permitted and sold with Hold-Open Clips per UL-2586 requirements.

B-20 Nozzles compatible up to B20 (20% Biodiesel)

Handwarmer Color	11A Leaded* 2 Piece Handwarmer	11B Leaded 2 Piece Handwarmer
Green	11A-0100-B20	11B-0100-B20
Black	11A-0400-B20	11B-0400-B20
Yellow	11A-0900-B20	11B-0900-B20

*11A Nozzles are no longer permitted and sold with Hold-Open Clips per UL-2586 requirements.



OPW 11A® AND 11B® Automatic Nozzles

The OPW 11® Series automatic nozzles are OPW's premium conventional nozzles for safe retail and commercial petroleum filling. The OPW 11® Series is the most trusted conventional nozzle in the world for full-service use. The OPW 11B® Series is designed for use in retail and commercial filling applications including prepay, self and full service, credit/debit card readers or card-lock systems to help prevent gasoline spills. The OPW 11B® will not open until the pumping system is pressurized, and closes automatically when the pressure is removed.

OPW 7H® AND 7HB® Automatic Shut-OFF Nozzles

For Heavy-Duty, High-Flow Truck, Bus & Fleet Service

If you operate a full-service truck stop, refuel your own fleet or manage a card-lock refueling location, the low-cost, long life and durability of the OPW 7H® high-flow nozzle can help increase your productivity, sales and profits. The OPW 7HB® will not open until the pumping system is pressurized, and closes automatically when the pressure is removed.

Listings and Certifications



See pages 168 - 174 for certification number

Materials

- Body:** Aluminum
- Lever & Lever Guard:** Duratuff®
- Packing:** Graphite with Teflon®
- Disc:** Viton®
- Weight:** 2.73 lbs. each, 43.1 lbs./ case of 15
1.25 kg each, 19.9 kg/ case of 15

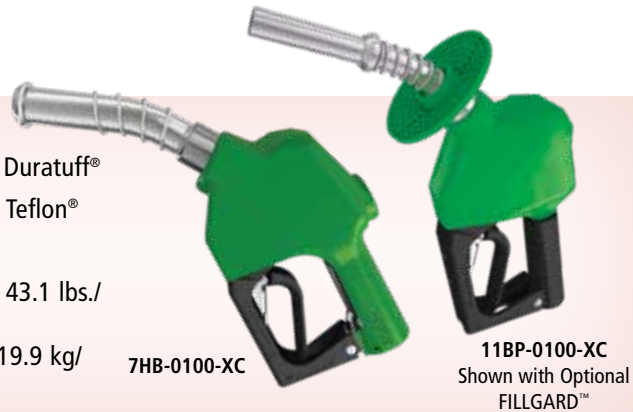

Nozzles (above) shown with optional hand-insulator. Hand insulator not included.

Features

Safe for Use

- ◆ UL-Listed for use in gasoline, diesel, and up to 10% ethanol blends. Specific listings available at www.opwglobal.com
- ◆ Prevents gasoline and/or diesel spills in prepay or card-lock systems utilizing OPW's unique No-Pressure - No-Flow Device. The nozzles cannot be opened until the pumping system is pressurized, and close automatically when the pressure is removed. (OPW 11B® and 7HB® Series Only)
- ◆ Prevents consumer from jamming the nozzle in an open position – Blocker on lever guard.
- ◆ FlowLock™ allows nozzle

to shut off when falling out of a vehicle, and tipped up, limiting spillage and unsafe conditions.

Durable & Long Lasting Design

- ◆ Compatible to -54°C [-65°F]
- ◆ Cycle-tested and proven to last longer than 1 million cycles - Better than any other nozzle available on the market today.
- ◆ Durable lever guard that won't scratch your customers' vehicles – made from Duratuff®.
- ◆ New hold-open clip spring lasts longer than previous designs. (OPW 11B® and 7HB® Series Only)
- ◆ Easy to use – Utilizing Accu-Stop® to-the-penny Flow Control Technology.

Ordering Specifications

Product #	Description
11B-0100-XC	Extreme Cold-Weather, 3/4" NPT Auto-Diesel Nozzle, 11B, Green
11B-0400-XC	Extreme Cold-Weather, 3/4" NPT Auto-Diesel Nozzle, 11B, Black
11B-0900-XC	Extreme Cold-Weather, 3/4" NPT Auto-Diesel Nozzle, 11B, Yellow
11BP-0100-XC	Extreme Cold-Weather, 3/4" NPT Gasoline Nozzle, 11BP, Green
11BP-0300-XC	Extreme Cold-Weather, 3/4" NPT Gasoline Nozzle, 11BP, Red
11BP-0400-XC	Extreme Cold-Weather, 3/4" NPT Gasoline Nozzle, 11BP, Black
7HB-0100-XC	Extreme Cold-Weather, 1" NPT Diesel Nozzle, 7HB, Green
7HB-0400-XC	Extreme Cold-Weather, 1" NPT Diesel Nozzle, 7HB, Black
7HB-0900-XC	Extreme Cold-Weather, 1" NPT Diesel Nozzle, 7HB, Yellow
11B-0100-XCB20	Extreme Cold-Weather, 3/4" NPT Auto-Diesel Nozzle, 11B, B20, Green
11B-0400-XCB20	Extreme Cold-Weather, 3/4" NPT Auto-Diesel Nozzle, 11B, B20, Black
11B-0900-XCB20	Extreme Cold-Weather, 3/4" NPT Auto-Diesel Nozzle, 11B, B20, Yellow
14C-0100XC	Extreme Cold-Weather, 3/4" NPT Gasoline Nozzle, 14C, Green
14HC-0100-XC	Extreme Cold-Weather, 1" NPT Truck Diesel Nozzle, B20, Green
14HC-0400-XC	Extreme Cold-Weather, 1" NPT Truck Diesel Nozzle, B20, Black
14HC-0900-XC	Extreme Cold-Weather, 1" NPT Truck Diesel Nozzle, B20, Yellow

Replacement Parts

Name	Product #	Description	Used For:
11AK Leaded Spout Kit	5BS-2110XC	11A, 1 1/16" O.D. Leaded Spout	11AK Spout Replacement
11AKP Unleaded Spout Kit	5BPS-2117XC	11AP, 1 3/16" O.D. Unleaded Spout	11AKP Spout Replacement
11B Leaded Spout Kit	5BBS-2135XC	11B, 1 5/16" O.D. Leaded Spout	11B Spout Replacement
11BP Unleaded Spout Kit	5BBPS-2137XC	11BP, 1 3/16" O.D. Unleaded Spout	11BP Spout Replacement

*Beginning April 30, 2015, nozzles with Hold-Open clips must have a B-Cap no-pressure no-flow device or an Interlock feature to be UL-2586 approved.

Customize and Colorize



Imprint your company logo or custom message to any color hand-insulator

OPW can help you enhance your brand image, drive traffic into your store, and deliver important messages to your customers with its new Enhanced Nozzle Program.

Now you can imprint company names, logos and/or special promotional messages on to your nozzles!

Differentiate your store from all others. Choose from a wide array of standard hand-insulator colors or create your own custom color hand-insulator.

We offer you the convenience of choice.

Simply provide high-resolution PDF of your Logo Artwork.

OPW AdMaster™

A highly effective and affordable way of advertising that drives traffic from the island to your in-store profit centers.

- ◆ Installs quickly and easily on your OPW nozzle!
- ◆ Increase In-store Sales - get customers from the island into your profit centers
- ◆ Puts your message right in your customer's hand
- ◆ Replaceable - easily updated to current promotions
- ◆ Available on new nozzles or can be installed quickly on existing nozzles
- ◆ Available in a variety of colors



Easy Snap-on Rubber Cover



Clear Cover

3 in. x 3 in.
Message Area

Ordering Specifications

Part #	Description
NTK11-0100	11 Series GREEN Advertising Insulator and Clear Cover Kit
NTK11-0200	11Series SILVER Advertising Insulator and Clear Cover Kit
NTK11-0300	11 Series RED Advertising Insulator and Clear Cover Kit
NTK11-0400	11 Series BLACK Advertising Insulator and Clear Cover Kit
NTK11-0500	11 Series BLUE Advertising Insulator and Clear Cover Kit
NTK11-0800	11 Series ORANGE Advertising Insulator and Clear Cover Kit
NTK11-0900	11 Series YELLOW Advertising Insulator and Clear Cover Kit
206252	Clear Cover



OPW Factory-Assembled Hose Kits

Factory-assembled OPW Hose Kits include all components from the whip hose to the nozzle. Each connection is tested for pressure tightness and continuity. Customize your hose kits by choosing from a variety of nozzles, swivels, breakaways and hoses. By selecting an OPW Hose Kit, you'll save time and money as opposed to purchasing and installing each item separately.

Features

- ◆ Quick and easy installation
- ◆ Save costs vs. purchasing items separately
- ◆ Reduce downtime
- ◆ Quality components
- ◆ Customizable
- ◆ Various renewable fuels, biodiesel, ethanol blends available
- ◆ Each hose kit is tested

Unleaded and Diesel Packages Include

A Nozzles (Standard colors available)

11BP	3/4" Unleaded, No Pressure - No Flow
14E	3/4" Unleaded, CARB-Approved, Dripless
14BP	3/4" Unleaded, Automatic Dripless
11B	3/4" Leaded/Diesel, Automatic Standard
14C	3/4" Auto-Diesel, Diesel Capture Technology
7HB	1" High-Flow Diesel, No Pressure - No Flow
14HC	1" High-Flow Diesel, Diesel Capture Technology

B Swivels

241TPS	3/4" & 1" Gasoline & Diesel, 2-plane, 270-degree rotation
45	3/4" & 1" Gasoline & Diesel, 2-plane, 360-degree rotation
66SB	3/4" & 1" Gasoline & Diesel, Swivel Breakaway

Contact OPW Customer Service for renewable fuel, ethanol, biodiesel blends – and for vapor-recovery system conversions.

FEATURED HOSE KITS

Unleaded

PK-EZR0300	11BP Nozzle (Red), 68EZR Breakaway, 241TPS Swivel, Std. Hose Length
PK-EZR0400	11BP Nozzle (Black), 68EZR Breakaway, 241TPS Swivel, Std. Hose Length
PK-EZR0500-E25	11BP-E25 Nozzle (Blue), 68EZR-75RF Breakaway, 241TPS-75RF Swivel, Std. Hose Length
PK-66V0992-E85	11BP-E85 Nozzle (Yellow), 66V-0492 Breakaway, 241TPS-0492 Swivel, E85 Hose Std. Length
PK-14E0400241EZR-LP	14E Nozzle (Black), 68EZR Breakaway, 241TPS Swivel, Low Perm Hose Std. Length

Diesel (Auto & High-Flow)

PK-EZR0100-L1	11B Nozzle (Green), 68EZR Breakaway, 241TPS Swivel, Std. Hose Length
PK-14C0100241EZR-L1	14C Nozzle (Green), 68EZR Breakaway, 241TPS Swivel, Std. Hose Length
PK-EZR7HB0100-45-8H	7HB Nozzle (Green), 68EZR Breakaway, 45 Swivel, 8 ft Curb Hose
PK-14HC241EZR0100-H12	14HC Nozzle (Green), 68EZR Breakaway, 241TPS Swivel, 12 ft Curb Hose



Listings and Certifications



C Breakaways

66V	3/4" & 1" Gasoline & Diesel, Single-Use
66REC	3/4" Gasoline & Diesel, Reconnectable
66SB	3/4" & 1" Gasoline & Diesel, Swivel Breakaway
68EZR	3/4" & 1" Gasoline & Diesel, Enhanced Reconnection Technology

D Curb Hoses

66H	3/4" & 1" Gasoline & Diesel, E25, E85, Low-Perm Available
-----	---

E Whip Hoses

66H	3/4" & 1" Gasoline & Diesel, E25, E85, Low-Perm Available
-----	---

F Splash Guard

FILLGARD Splash Guard will match nozzle's hand insulator on 11BP, 14BP, 11B, 7HB

Contact Customer Service for additional configurations.

Materials

- Body:** Aluminum
- Lever & Lever Guard:** Duratuff®
- Packing:** Graphite with Teflon®
- Disc:** Viton®
- Spouts:** Aluminum
- Inlet Size:** 3/4" NPT
- Weight:** 2.85 lbs. each, 44.90 lbs./case of 15
1.3kg each, 20.4kg/case of 15

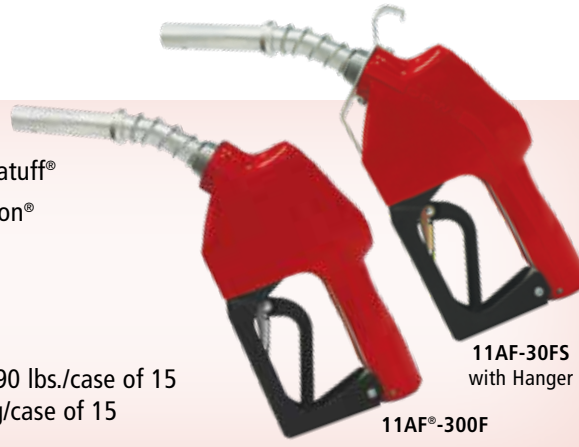

OPW 11AF® 3/4" Automatic Nozzles

The OPW 11AF® Nozzle is a sturdy industry-proven standard used primarily for fueling up to 15 gallons per minute. The 11AF® is an automatic dispensing nozzle designed for use in transfer pump. This nozzle should not be used for retail applications, and does not include a No-Pressure - No-Flow or Interlock Device.

Features

- ◆ The new and improved farm hanger is now made from stamped metal and bolted to the nozzle, making it stronger and sturdier than ever.
- ◆ UL- and ULc-Listed for use in gasoline, diesel and up to 10% ethanol blends. Specific listings available at www.opwglobal.com.
- ◆ New bleeder poppet orifices allow for use in transfer pumps with or without air-elimination systems.
- ◆ Prevents consumer from jamming the nozzle in an open position – blocker on lever guard.
- ◆ Durable lever guard that won't scratch your customers' vehicles – made from Duratuff®.
- ◆ Easy to use – utilizing Accu-Stop® to-the-penny Flow Control Technology.
- ◆ Works with self-priming and non-self-priming pumps.

Design working pressure

- ◆ 50 psi (3.45 bar) maximum pressure.

Ordering Specifications

Full Hand Insulator Color	Includes spout, hanger, spring and no hold-open rack		Includes spout, standard spring and no hold-open rack		Includes spout, hanger, spring and no hold-open rack	
	For Unleaded Service	For Diesel Service	For Unleaded Service	For Diesel Service	For Leaded Service	For Unleaded Service
Green	11AF-10FS					
Red	11APF-30FS		11AF-300F	11APF-300F		
Black	11APF-40FS	11AF-40FS			11AF-4FSC	11APF-4FSC

*Beginning April 30, 2015; nozzles without a no-pressure no-flow or interlock device may not be ULc-listed with Hold-Open Clips.

Replacement Spout Kits

Product #	O.D.		Length		Weight		Used On
	in.	mm	in.	mm	lbs.	kg	
5BF-0112	15/16	24	7	178	.59	.27	11AF®
5BPF-0172	13/16	21	7	178	.59	.27	11APF

NEWGARD™ Kits See page 156.

Listings and Certifications



See pages 168 - 174 for certification number

WARNING

Do not use OPW 11AF Nozzles for any retail application. It is only intended for use in non-retail applications. Use of foreign objects to hold open automatic nozzles could result in failure to shut off and personal injury.

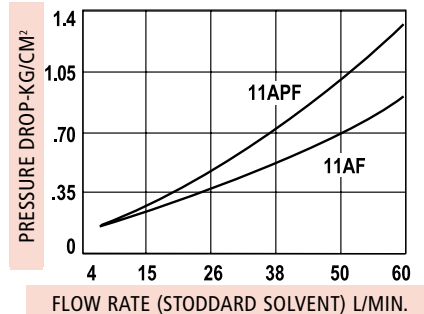
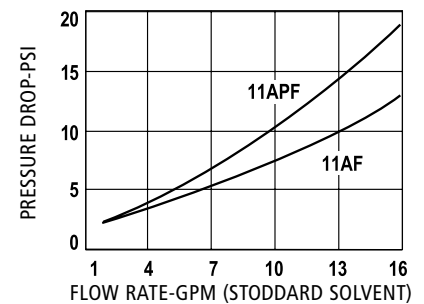

FIRST to Meet NEW UL-2586 Requirements

OPW 7H® and 7HB® Automatic Shut-off Nozzles

For Heavy-Duty, High-Flow Truck, Bus & Fleet Service

If you operate a full-service truck stop, refuel your own fleet or manage a card-lock refueling location, the low-cost, long-life and durability of the OPW 7H® high-flow nozzle can help increase your productivity, sales and profits.

Materials

- Body:** Aluminum
- Lever & Lever Guard:** Duratuff®
- Packing:** Graphite with Teflon®
- Disc:** Viton®
- Spout:** Aluminum
- Inlet Size:** 1" NPT
- Weight:** 3.35 lbs. each, 52.05 lbs./case of 15
1.51 kg each, 23.6 kg/case of 15



7H®

7HB®

Features

Safe for Use

- ◆ UL- and ULc-Listed for use in gasoline, diesel and up to 10% ethanol blends. Specific listings available at www.opwglobal.com.
- ◆ Prevents gasoline spills in prepay or card-lock systems utilizing OPW's unique No-Pressure - No-Flow Device. The nozzle cannot be opened until the pumping system is pressurized, and closes automatically when the pressure is removed. (7HB Series only)
- ◆ Prevents consumer from jamming the nozzle in an open position – blocker on lever guard.
- ◆ FlowLock™ allows nozzle to shut off when falling out of a fill pipe, and is tipped up, limiting spillage and unsafe conditions.
- ◆ Reliably low shut off – specifically designed to ensure proper automatic shut off as low as 5 gallons per minute.

Durable and Long Lasting Design

- ◆ Cycle-tested and proven to last longer than 1 million cycles – better than any other nozzle available on the market today.*

- ◆ Durable lever guard that won't scratch your customers' vehicles – made from Duratuff®.
- ◆ New hold-open clip spring lasts longer than previous designs.

Appealing to Customers

- ◆ Easy to use – utilizing Accu-Stop® to-the-penny Flow Control Technology.
- ◆ Easy to open, even at high pressures, utilizing Dual Poppets.
- ◆ Even, smooth spray pattern – minimizes diesel foaming and false shut offs.
- ◆ Smooth closing action and reduced line shock from incorporated dashpot technology.
- ◆ Convenient – one-finger hold-open clip that is easy to set the flow rate. (not on all models)
- ◆ Spout Retaining Ring – adds extra measure in securing nozzle spout in fill pipe where required. (not on all models)

Design working pressure

- ◆ 50 psi (3.45 bar) maximum pressure.
- * **OPW internal lab-testing results as of August 2010.**

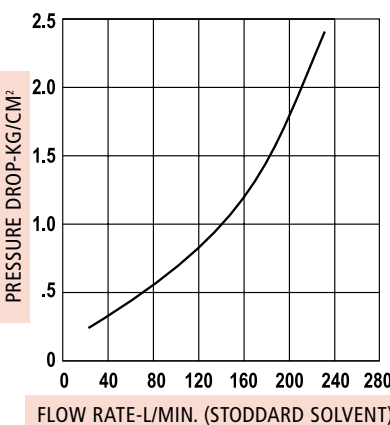
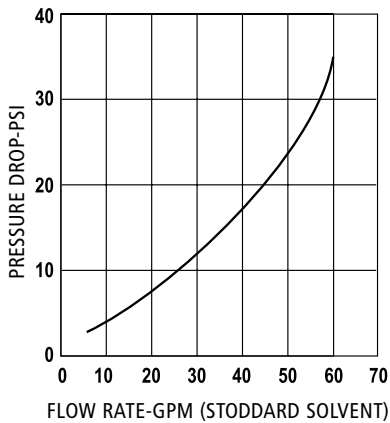

Listings and Certifications

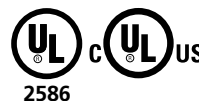

See pages 168 - 174 for certification number

⚠ WARNING

In order to be UL-2586 approved effective April 30, 2015, the use of a Hold-Open device is only permitted on dispensing nozzles equipped with a "B-Cap" (no-pressure - no-flow) or interlock feature. The use of foreign objects to hold open automatic nozzles could result in shut off failure and personal injury.

Ordering Specifications

B-5 Nozzles compatible up to B5 (5% Biodiesel), Fuel Oil and Kerosene				
Handwarmer Color	7H** with Spout Ring	7H** without Spout Ring	7HB® with Spout Ring	7HB® without Spout Ring
Green	7H-0100	7H-5100	7HB-0100	7HB-5100
Black	7H-0400	7H-5400	7HB-0400	7HB-5400
Yellow	7H-0900	7H-5900	7HB-0900	7HB-5900
Bare	-	-	7HB-0090	7HB-5009

NOTE: All new 7H and 7HB nozzles now come with FILLGARD™. For replacement FILLGARDs, see page 154.
*7H Nozzles are no longer permitted and sold with Hold-Open Clips per UL-2586 requirements.

B-20 Nozzles compatible up to B20 (20% Biodiesel)				
Handwarmer Color	7H** with Spout Ring	7H** without Spout Ring	7HB® with Spout Ring	7HB® without Spout Ring
Green	7H-0100-B20	7H-5100-B20	7HB-0100-B20	7HB-5100-B20
Black	7H-0400-B20	7H-5400-B20	7HB-0400-B20	7HB-5400-B20
Yellow	7H-0900-B20	7H-5900-B20	7HB-0900-B20	7HB-5900-B20

NOTE: All new 7H and 7HB nozzles now come with FILLGARD™. For replacement FILLGARDs, see page 154.
*7H Nozzles are no longer permitted and sold with Hold-Open Clips per UL-2586 requirements.

Replacement Parts

Product	Part #	O.D.*		Length		Weight		Used On
		in.	mm	in.	mm	lbs.	kg	
7H Spout Kit w/ spout ring	5BH-0115	1 3/16*	30	7	178	.66	.30	7H®
7H Spout Kit w/o spout ring	5BH-5115	1 3/16	30	7	178	.66	.30	7H® (w/o ring)
12-inch 7H Spout Kit	5BHB-0125	1 3/16	30	12	305			7H®

NEWGARD™ Kits See page 154

Product	Part #	O.D.*		Length		Weight		Used On
		in.	mm	in.	mm	lbs.	kg	
7HB Spout Kit w/ spout ring	5BBH-0136	1 3/16*	30	7	178	.65	.30	7HB®
7HB Spout Kit w/o spout ring	5BBH-5136	1 3/16	30	7	178	.66	.30	7HB® (w/o ring)

NEWGARD™ Kits See page 154

* Spout end with anchor ring is 1 31/64" O.D.

7H®, 7HB® Series Instruction Sheet Order Number: **H15985M**

Custom Colors

With minimum quantities.
Contact OPW customer service.

Blue

Red

Silver



OPW 5BH
7H° Spout with ring



OPW 5BBH
7HB° Spout without ring

NOTE: See OPW's Website at www.opwglobal.com for product instruction sheets, troubleshooting guides, how-to-use guide and to view the Do's & Don'ts at the Gas Pump video.

**OPW NEWGARD™
Full Hand Insulator**

All OPW 7 Series, Astro Series, and 11A® Series nozzles are furnished complete with NEWGARD™ hand-insulators. Available in a variety of colors.

**OPW NEWGARD™
Two-Piece Hand Insulator**

OPW 11A® and 11B® nozzles are furnished complete with NEWGARD™ 2-piece hand-insulators. For a more unique appearance, try our new two-piece design. OPW NEWGARD™ 2-piece hand-insulators make it easy to match new color schemes or replace soiled insulators without removing the nozzle from the hose.

**OPW 8 FILLGARD™
Splash Guard**

FILLGARD™ also enhances the appearance of your gasoline nozzle, and makes dispensing gasoline more pleasant for your customers. FILLGARD™ won't deform or crack in cold weather. FILLGARD™ is not standard on new 7 Series nozzles.



Ordering Specifications

Hand Insulator Color	NEWGARD™ 1 piece	NEWGARD™ 2 piece		FILLGARD™	
	7HB®	11A®	11B®	11A® & 11B®	7H® / 7HB®
Green	E00325M	D01773M	D01529M	8G-0100	8HG-0100
Silver		205217	D02078M	8S-0200	
Red	211218	D01775M	D01789M	8R-0300	8HR-0300
Black	E00324M	D01719M	D01532M	8BL-0400	8HBL-0400
Blue	H14846M	D01774M	D01790M	8B-0500	
Yellow	H11923M	D01776M	D01791M	8Y-0900	8HY-0900
Gold		205219	205206	8GL-0750	
Orange	205599	205248	205252	8O-0800	8HO-0800
		D01530M Barrel			

Note: Barrel and Hand Insulator sold separately.

Custom Colors: With minimum quantities. Contact OPW Customer Service.

- White
- Azure Blue
- Brown
- Light Red
- Dark Blue

Notes:

- 1) OPW may add or delete colors without notice.
- 2) Actual color may vary from production run to production run.
- 3) Custom colors available, minimum quantities applicable.**
- 4) Custom logos available for additional charge.**

** For ordering specifications not listed in this catalog, visit our website at www.opwglobal.com or contact Customer Service at 1-800-422-2525.

Materials

- Body:** Special resin- coated aluminum
- Lever & Lever Guard:** Duratuff®
- Seals:** Viton®
- Inlet Size:** M34
(adaptor required for each nozzle)
- Weight:**
2.41 lbs. each, 36 lbs./case of 15
1.1 kg each, 16.5 kg/case of 15



OPW 21Gu™ DEF Nozzle

The Industry's Most Comprehensive DEF-Filling Solution

- ◆ End-to-end dispensing hardware solution for reliable, efficient DEF-filling
- ◆ Industry standard DEF-filling solution in Europe
- ◆ Unique Mis-Filling Prevention Device (MFPD) provides unparalleled filling assurance and peace of mind
- ◆ Affordable mis-filling prevention insurance designed to protect your investment against potential mis-filling mishaps

Features – Benefits

- ◆ Automatic Shutoff Feature shuts off nozzle when the tank is full
- ◆ Mis-filling prevention device eliminates the risk of accidental DEF filling or environmental contamination.
- ◆ Spout with magnetic interface prevents mis-filling mishaps.
- ◆ Durable streamlined nozzle design for easy, comfortable nozzle handling makes it easy to differentiate DEF products.
- ◆ Total end-to-end affordable solution is a convenient and complete system from the Industry Leader.

- ◆ Comes with Integral Contaminant-Prevention Filter; this replaceable, stainless-steel, 40-mesh filter provides an added level of protection against DEF contaminants.
- ◆ Outfitted in that familiar and unmistakable "DEF Blue" with slogan badge for instant product identification.



21GU-FLTR



Maximum pressure and flow rate

- ◆ 40 psi (2.75 bar) maximum pressure.
- ◆ 10 gpm (37.8 lpm) maximum flow rate

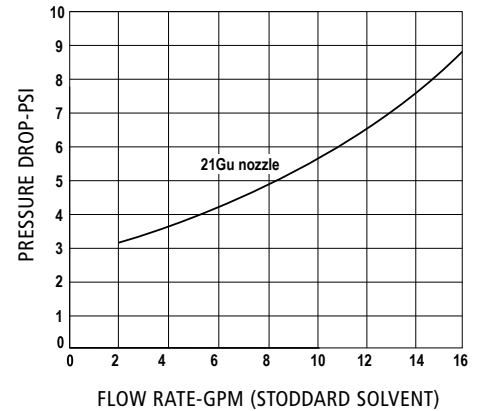

MIS-FILLING PREVENTION

Mis-Filling Prevention Device (MFPD)

WITH the OPW 21Gu nozzle and Mis-Filling Prevention Device (MFPD), your investment is safe.

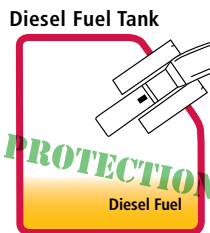
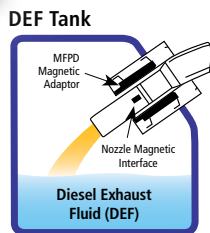

Nozzle Magnetic Interface is Not Actuated and DEF Cannot Contaminate Your Diesel Fuel Tank

Yes

Other DEF Nozzle

WITHOUT the OPW 21Gu nozzle and Mis-Filling Prevention Device (MFPD), your investment is at risk.

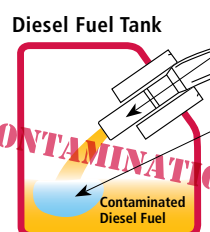
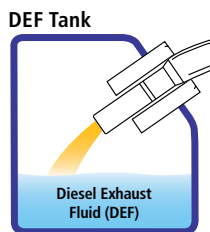

There is Nothing to Stop the Nozzle from Contaminating Your Diesel Fuel Tank

No

Are You Protected?

A fixed magnetic field within the Mis-Filling Prevention Device actuates a magnetic interface in the spout of the 21Gu nozzle to allow the flow of DEF. Without the Mis-Filling Prevention Device, the DEF nozzle will not flow. Put the nozzle in the wrong tank – say, your diesel tank – no problem, the nozzle will not flow. No other DEF-filling nozzle has this DEF mis-filling protection capability.

Listings and Certifications

ISO 22241 Compliant

Nozzle Ordering Specifications

Product #	Description
21GU-0400	Wayne® / Bennett® / Gasboy® (Model 9862XX-ZWW) Nozzle designed for use WITHOUT Mis-Filling Prevention Device
21GU-040G	Gilbarco® / Gasboy® (Model 9862KX-Z) Nozzle designed for use WITHOUT Mis-Filling Prevention Device
21GU-0500	Wayne® / Bennett® / Gasboy® (Model 9862XX-ZWW) Nozzle designed for use WITH Mis-Filling Prevention Device
21GU-050G	Gilbarco® / Gasboy® (Model 9862KX-Z) Nozzle designed for use WITH Mis-Filling Prevention Device

NOTE: Each nozzle requires one adaptor fitting to convert from M34 to 1" BSPP threads.



21GU-0500

21GU-050G

Replacement Parts

Product #	Description
212686	21GU-0500 & 050G Blue Hand Insulator
211817	21GU-0400 & 040G Black Hand Insulator
21GU-SPOUT -SA	DEF Replacement Spout designed for use WITH Mis-Filling Prevention Device
21GU-SPOUT-SA-N	DEF Replacement Spout WITHOUT Mis-Filling Prevention Device
215556	DEF Replacement Slogan Badge
21GU-FLTR	Strainer and Spacer Washer
212691	Blue Product Sleeve
211752	Black Product Sleeve

21Gu Nozzle Adaptor Ordering Specifications

Product #	Description
21GU-SSB	DEF Stainless-Steel Reconnectable Breakaway/Swivel - NOTE: One (1) 21GU-SSB is required for each nozzle. Hose connection end is 1" BSPP male thread.
21GU-BCS	Replacement DEF Swivel/Breakaway Cover Sleeve (Comes with 21GU-SSB)



21GU-SSB
Stainless-Steel Swivel/
Reconnectable Breakaway



21GU-BCS

Features

- ◆ SST construction and compatible with ISO 22241 Standard
- ◆ Converts nozzle from M34 threads to 1" BSPP
- ◆ Integral reconnectable breakaway 175-330 (lbs.) 80-150 (kg)
- ◆ Includes 21GU-BCS for attractive installation and protection of vehicles

OPW MIS-FILLING PREVENTION DEVICE (MFPD)

DEF mis-filling can be expensive. The OPW 21Gu MFPD offers the industry's most effective and affordable insurance policy against mis-filling mishaps – actually stopping them before they happen. There is no better way to protect your investment and the environment.



21Gu Mis-Filling Prevention Device

Product #	Description
MFPD	21Gu Mis-Filling Prevention Device (MFPD). Order one MFPD or Bulk Packed for OEM sales (420 per case) NOTE: The MFPD is permanently installed in DEF tank fill pipe. Contact your vehicle supplier and specify the OPW DEF Mis-Filling Prevention Device.
MFPD-Pak	Retail Packaged Mis-Fill Prevention (Each)

Materials

Hose:

O.D.: 1" (26 mm)

I.D.: 5/8" (16 mm)

Minimum bend radius: 3-1/2" (90 mm)

Thread connections: 1" BSPP female at both ends

Torque specification: 30-37 ft. lbs (40-50 Nm)



Features

- ◆ Specially designed for DEF-flow applications.
- ◆ Lightweight and highly flexible for easy customer handling.
- ◆ Smooth bore, seamless fluoropolymer lining for exceptional flow performance.
- ◆ Swivel end couplings provide easy installation.
- ◆ Durable, reliable, long-life performance and maximum flow efficiency.
- ◆ Anti-kinking sleeve at nozzle end to reduce wear on hose during use.

Ordering Specifications (standard lengths)

Product #	Description
21GU-H11	DEF Hose Assembly, 11 ft. for Bennett® & Gasboy® Dispensers
21GU-H12	DEF Hose Assembly, 12 ft.
21GU-H15	DEF Hose Assembly, 15 ft. for Separation by Design® Dispensers
21GU-H17G	DEF Hose Assembly, 17.4 ft. for Gilbarco® Retail and Wayne® Dispensers
21GU-H21	DEF Hose Assembly, 21 ft.
21GU-HRS	DEF Hose Replacement Seals (10 per pack)
204129	DEF Hose Coupling (comes with hose seal)
204130	DEF Anti-kinking Sleeve

Note: Need a different custom length? Contact OPW customer service at 1-800-422-2525.

OPW 21Gu Hose Assembly

The OPW 21Gu Series DEF Hose is the de facto standard for hoses in Europe. Designed with integral swivel couplings and an anti-kinking sleeve, the 21Gu hose is easy to install and use. The OPW 21Gu Hose meets compatibility testing as specified in ISO 22241 so that you can rest assured that your hose will last.

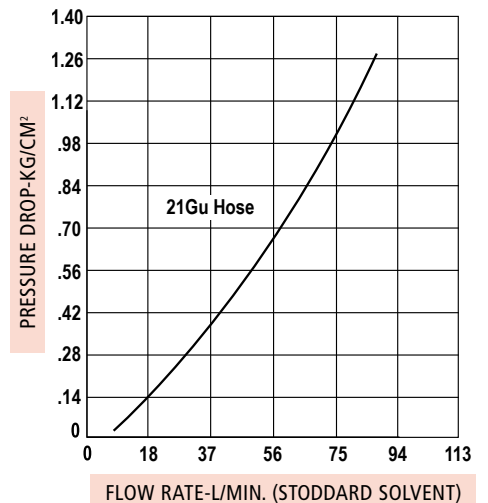
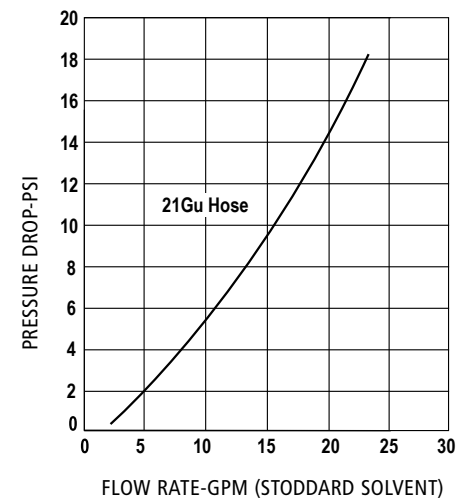

Conventional Swivels & Breakaways



- Swivel Breakaway Selection Chart..... 159
- Hose Swivels..... 160 - 161
- Swivel & Breakaways..... 162
- Reconnectable Breakaways 163 - 164
- Single-Use Breakaways..... 165
- 66H Series Hose..... 165
- Flow Limiters 167

SWIVELS

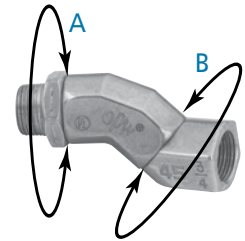
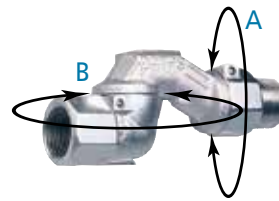

Model	365	241TPS	45
Rotation A	360°	360°	360°
Rotation B	N/A	270°	360°
O-Ring Design	Dual O-Ring – Viton®/Buna-N	Dual O-Ring – Viton®/Buna-N	Dual Seal – Viton®
3/4" Model	Yes	Yes	Yes
1" Model	Yes	Yes	Yes
Page	160	161	160
Cold-Weather Option	No	Yes (241TPS-0241C)	No

BREAKAWAYS



Model	66V	68EZR	66REC	66SB
Style	Single-Use	Reconnectable	Reconnectable	Reconnectable
Cost	<ul style="list-style-type: none"> • Low Initial Unit Cost • Requires Service Call To Replace 	<ul style="list-style-type: none"> • Higher Initial Unit Cost • No Service Call Required To Reconnect 	<ul style="list-style-type: none"> • Higher Initial Unit Cost • No Service Call Required To Reconnect 	<ul style="list-style-type: none"> • Higher Initial Unit Cost • No Service Call Required To Reconnect
Application	<ul style="list-style-type: none"> • High Hose Dispensing • Requires Whip Hose 	<ul style="list-style-type: none"> • High Hose Dispensing • Requires Whip Hose 	<ul style="list-style-type: none"> • High Hose Dispensing • Requires Whip Hose 	<ul style="list-style-type: none"> • No Whip Hose Required
3/4" Model	Yes	Yes	Yes	Yes
1" Model	Yes	Yes	N/A	Yes
Other Features	Available with a Whip Hose Combination	Audible Click	Audible Click	Combines Swivel & Breakaway
Page	165	163	164	162
Cold-Weather Option	No	Yes	Yes	Yes

OPW 45 Hose Swivel

The OPW 45 swivel is designed for gasoline self-service applications where easy nozzle and hose handling is important for customer convenience. The 45 is installed between the nozzle and hose to reduce strain, providing flexibility so fueling hoses last longer.

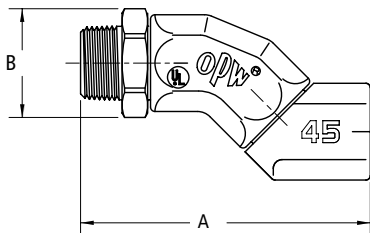
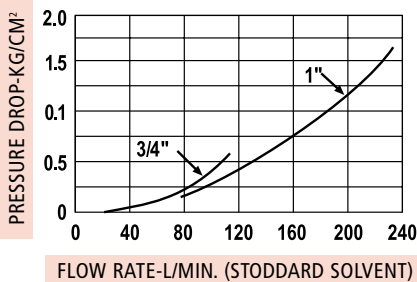
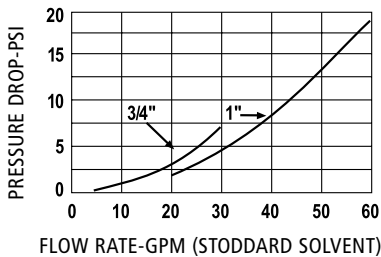

OPW 36S Hose Swivel

Designed for use with fuel-oil nozzles (at inlet only), the OPW 36S provides 360° swivel action. The full-circle swivel reduces the physical strain of aligning the nozzle with the fill pipe.

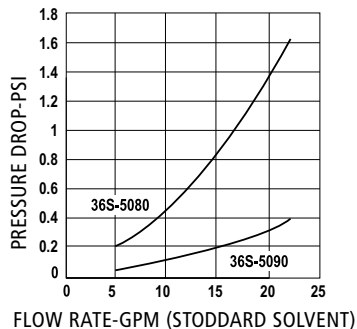

Materials

- Body:** Aluminum
- Outlet Adaptor:** Zinc
- Inlet Adaptor:** Zinc
- Seals:** Buna-N
- Weight:** 3/4": .65 lbs. each; .30 kg
1": 1.16 lbs. each; .53 kg
- Packed:** 20 per Case (45-5060)
30 per Case (45-5075)



Features

- ◆ UL and ULC-listed for use in gasoline, diesel, and up to 10% ethanol blends. Specific listings available at www.opwglobal.com.
- ◆ Compact, attractive profile for a sleek, modern appearance.
- ◆ Secure design not repairable or rebuildable for certainty of operation. Every OPW 45 is factory assembled and tested.
- ◆ Better flow performance and less restriction means higher refueling speeds.
- ◆ Unique 2 planes of rotation for easy nozzle positioning and hose life.
- ◆ 50 psi (3.45 bar) maximum pressure.

Ordering Specifications

Product #	Size	Overall Length		Across Corners		Weight	
		A	B	lbs.	kg		
45-5060	3/4" F x 3/4" M (NPT)	4 1/8"	1 3/16"	.65	.30		
20 per case	19 mm x 19 mm	105 mm	40 mm				
45-5075	1" F x 1" M (NPT)	4 3/4"	1 7/8"	1.16	.53		
20 per case	25 mm x 25 mm	121 mm	48 mm				

Materials

- Body:** Aluminum
- Adaptor:** Zinc
Aluminum
- Seals:** Buna-N O-Ring,
Viton® O-Ring
- Bearings:** Nylon



Ordering Specifications

Product Number	Inlet Thread x Outlet Thread	lbs.	kg
36S-5080	3/4" M x 3/4" F (NPT)	0.30	0.14
	(19 mm x 19 mm)		
36S-5090	1" M x 1" F (NPT)	0.40	0.18
	(25 mm x 25 mm)		

Listings and Certifications



NOTE: See OPW's Website at www.opwglobal.com for product instruction sheets, troubleshooting guides, how-to-use guide and to view the Do's & Don'ts at the Gas Pump video.

OPW 241TPS Series Hose Swivels

The OPW 241TPS Series of swivels are designed and rigorously tested for applications where easy nozzle and hose handling is important for customer convenience. Swivels are installed in between the nozzle and the hose to provide flexibility in the system to reduce customer strain, position the nozzle properly and reduce premature hose wear.

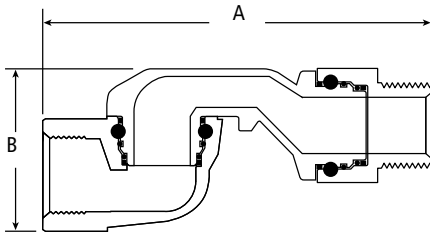
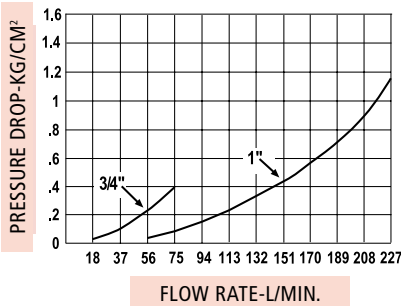
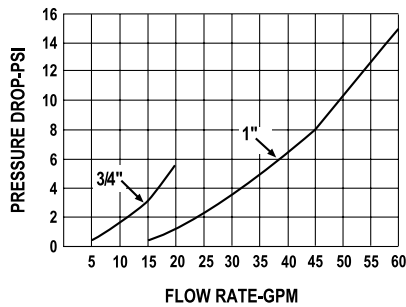

Materials

- Body:** Aluminum
- Inlet Adaptor:** Zinc
- Outlet Adaptor:** Zinc
- Seals:** Buna-N, Viton®
- Bearing:** Nylon
- Weight:** 3/4": .65 lbs., .30 kg
1": 1.55 lbs., .70 kg
- Packed:** 60 per Case



Features

- ◆ UL and ULc-listed for use in gasoline, diesel, and up to 10% ethanol blends. Specific listings available at www.opwglobal.com.
- ◆ Allows for easy nozzle positioning in fill pipes – utilizing two planes of rotation.
- ◆ Reduces premature hose wear – utilizing two planes of rotation.
- ◆ Added protection vs. thermal and chemical degradation – Dual Seals.
- ◆ 50 psi (3.45 bar) maximum pressure.

Ordering Specifications

Product #	Inlet/Outlet	Length A	Depth B
241TPS-0241	3/4" F x 3/4" M (NPT)	4 7/8"	2 3/16"
241TPS-0492* (E85)			
241TPS-75RF** (E25/B20)	19 mm x 19 mm	124 mm	56 mm
241TPS-1000	1" F x 1" M (NPT)	6 1/32"	2 17/32"
241TPS-10RF*** (B20)	25 mm x 25 mm	153 mm	64 mm

*241TPS-0492 is UL-listed for up to 85% Ethanol.

**241TPS-75RF is UL-listed for up to 25% Ethanol and 20% Biodiesel.

***241TPS-10RF is UL-listed for up to 20% Biodiesel.

Listings and Certifications



NOTE: See OPW's Website at www.opwglobal.com for product instruction sheets, troubleshooting guides, how-to-use guide and to view the Do's & Don'ts at the Gas Pump video.

Materials

- Body:** Aluminum
- Sleeve:** Nylon, HDPE
- Seals:** Viton®
- Spring:** Stainless-steel
- Poppet:** Aluminum
- Packed:** 20 per Case

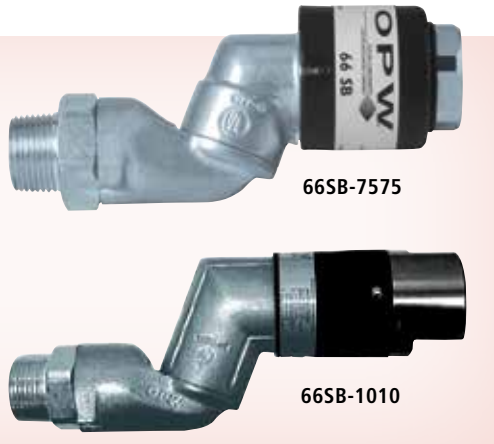

OPW 66SB Swivel Breakaway

The OPW 66SB Swivel Breakaway is intended for easy installation at the nozzle inlet. The compact, lightweight design incorporates a 360° swivel rotation at both the male end and middle joint, with a simple and easily reconnectable breakaway on the opposite end.

Features

- ◆ UL and ULc-listed for use in gasoline, diesel and up to 10% ethanol blends. Specific listings available at www.opwglobal.com.
- ◆ Pull Force – the 66SB will break away with a pull force of no more than 350 lbs.
- ◆ Easily Reconnected at Waist Height – after relieving line pressure, simply push coupling halves together until latched. Reconnection force is approximately 15 lbs.
- ◆ Protected Coupling and Poppet – the breakaway’s poppet and sealing surface are protected from impact during separation by a plastic sleeve.

- ◆ Reduces Connections – the single-unit design replaces the standard swivel, breakaway and whip hose, eliminating possible leak points.
- ◆ Double O-Ring Seal – both swivel joints are protected by a double O-Ring design.

Design working pressure

- ◆ 50 psi (3.45 bar) maximum pressure.

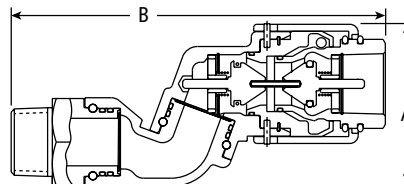

Ordering Specifications

Product #	Size	Weight	
		lbs.	kg
66SB-7575	3/4" x 3/4" (NPT)	1	0.45
66SB-1010	1" x 1" (NPT)	1.82	0.83

Dimensions

Product #	A		B	
	in.	mm	in.	mm
66SB-7575	2 1/2"	64	5 29/32"	150
66SB-1010	3 11/32"	85	8 1/2"	216

66SB Instruction Sheet Order Number: F-69

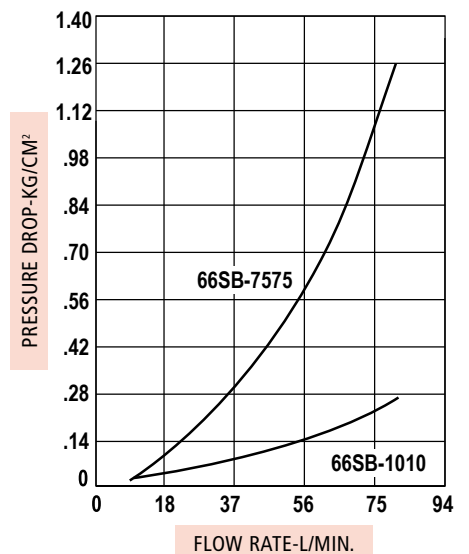
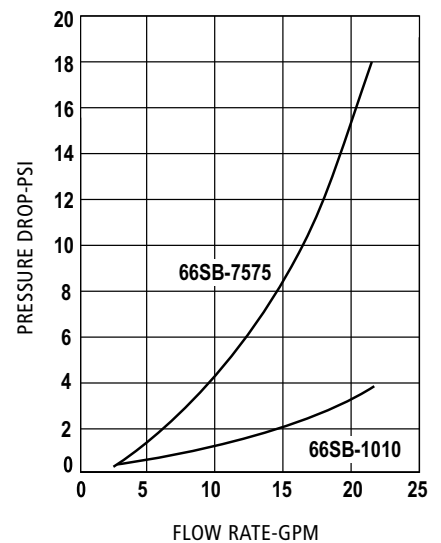

Listings and Certifications

OPW 68EZR Series 3/4" and 1" Dry- Reconnectable Breakaway

The OPW 68EZR Reconnectable Breakaway has been designed for retail-fueling operations to deliver an increased level of security in the event of a drive off. Not only is it the fastest and easiest breakaway in the industry to reconnect, but also the one that delivers the greatest peace of mind that it is securely reconnected. Built on the 66REC breakaway technology platform, the 68EZR delivers trusted OPW quality and proven technology at the lowest cost of ownership. The 68EZR is installed on fuel-dispensing hoses and will separate when subjected to a designated pull force. Upon separation, the dual valves seat automatically, stopping the flow of fuel and limiting any fuel spillage, while protecting the dispensing equipment. For proper operation on high-hanging hoses, the OPW 68EZR must always be installed with a "straightening" hose, such as the OPW 66H. For low-hose applications, the OPW 68EZR should be installed downstream of the retractor cable.

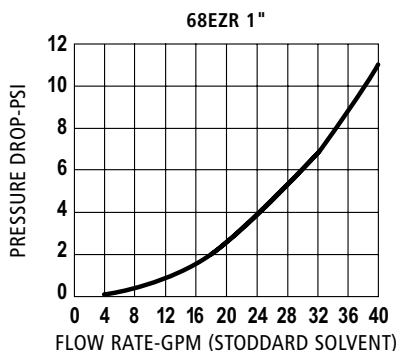
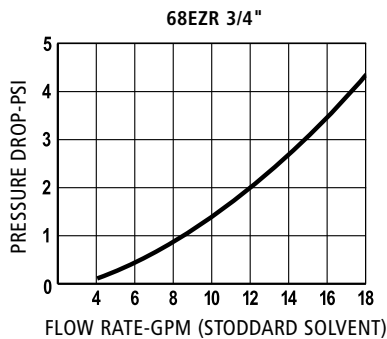

Materials

3/4" 68EZR

Body: Die-cast zinc
Protective Sleeves: Impact-Resistant Super-tough Nylon
Main Seals: Viton® & Fluorosilicone
Main Spring: Stainless-steel
Guide and Poppets: Acetal/Delrin
Packed: 20 per Case

1" 68EZR

Body: Aluminum
Protective Sleeves: Impact-Resistant Super-tough Nylon
Main Seals: Viton® & Fluorosilicone
Main Spring: Stainless-steel
Guide and Poppets: Acetal/Delrin
Packed: 20 per Case



Features

- ◆ UL and ULC-listed for use in gasoline, ethanol blends up to 25% (E25), diesel, and biodiesel blends up to 20% (B20). Specific listings available at www.opwglobal.com.
- ◆ Pull Force – the 68EZR will break away with a pull force of no more than 350 lbs.
- ◆ Unique Double-Poppet Design – features low pressure drop.
- ◆ Coupling Halves – protected by proven plastic sleeves.
- ◆ Easily Reconnected – features "Push-Twist-Click" technology; simply realign the valve, push in and then twist until you hear the audible click.
- ◆ Cold-weather compatible
- ◆ Reconnection force of approximately 7 lbs.
- ◆ Line Shock – the OPW 68EZR is able to absorb the effects of normal line shock through the unique design of the disconnecting features.
- ◆ 50 psi (3.45 bar) maximum allowable operating pressure.

Ordering Specifications

Product #	Size	mm	Weight	
			lbs.	kg
68EZR-7575	3/4" (NPT)	19	1.2	0.54
68EZR-75RF*	3/4" (NPT)	19	1.2	0.54
68EZR-1010	1" (NPT)	25	1.2	0.54
68EZR-10RF**	1" (NPT)	25	1.2	0.54

*68EZR-75RF is UL and ULC-listed for use in gasoline, ethanol blends up to 25% (E25), diesel, and biodiesel blends up to 20% (B20).

**68EZR-10RF is UL and ULC-listed for use in diesel, and biodiesel blends up to 20% (B20).

Replacement Parts

Part #	Description
211143	3/4" Main Seal
8509	1" Main Seal

68EZR Series Instruction Sheet Order Number: 208080

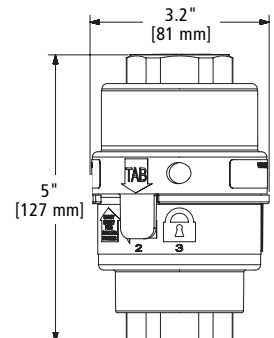
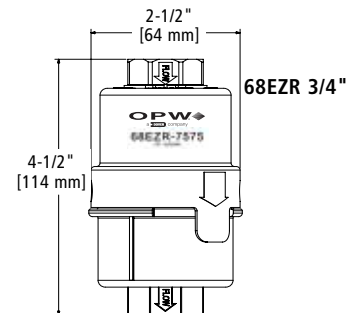

Listings and Certifications



U.S. PAT. 9,528,648

Materials

- Body:** Die-cast zinc
- Protective Sleeves:** Impact-resistant nylon
- Main Seals:** Viton®
- Main Spring:** Stainless-steel
- Guide and Poppets:** Acetal
- Packed:** 20 per Case

66REC



**OPW 66REC
3/4" Dry-Reconnectable
Breakaway**

The OPW 66REC is the first dry-reconnectable breakaway for the conventional dispensing market. It is designed to be installed on fuel-dispensing hoses and will separate when subjected to a designated pull force. The dual valves seat automatically, stopping the flow of fuel and limiting any fuel spillage, while protecting the dispensing equipment. When reconnecting the separated halves, the 66REC seals tightly on an O-ring before the poppet stems engage to open the valve. For proper operation on high-hanging hoses, the OPW 66REC 3/4" must always be installed with a "straightening" hose with a minimum length of 9", such as the OPW 66H. For low-hose applications, the OPW 66REC should be installed downstream of the retractor cable.

Features

- ◆ UL and ULc-listed for use in gasoline, diesel and up to 10% ethanol blends. Specific listings available at www.opwglobal.com.
- ◆ Pull Force – the 66REC-1000 will break away with a pull force of no more than 350 lbs.
- ◆ Unique Double-Poppet Design – features low pressure drop.
- ◆ Coupling Halves – protected by proven plastic sleeves.
- ◆ Easily Reconnected – just "push and twist" until you hear the audible click, signifying the unit has been correctly reconnected. Reconnection force approximately 15 lbs.
- ◆ May be reconnected under wet or dry hose conditions.
- ◆ Cold-weather compatible
- ◆ Line Shock – the OPW 66REC is able to absorb the effects of normal line shock through the unique design of the disconnecting features.

Design working pressure

- ◆ 50 psi (3.45 bar) maximum pressure.

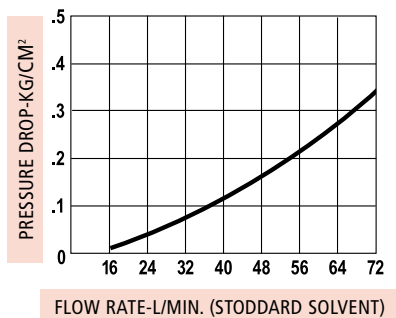
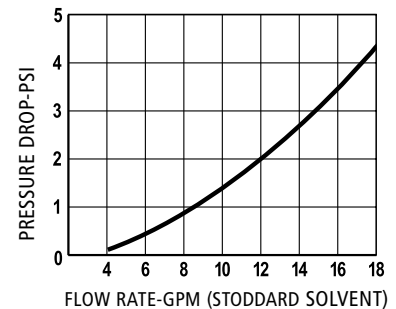
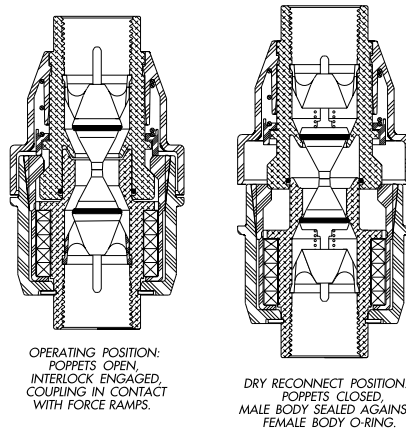

Ordering Specifications

Product #	in.	mm	lbs.	kg
66REC-1000	3/4" (NPT)	19	1.2	.54

NOTE: See OPW's Website at www.opwglobal.com for product instruction sheets, troubleshooting guides, how-to-use guide and to view the Do's & Don'ts at the Gas Pump video.

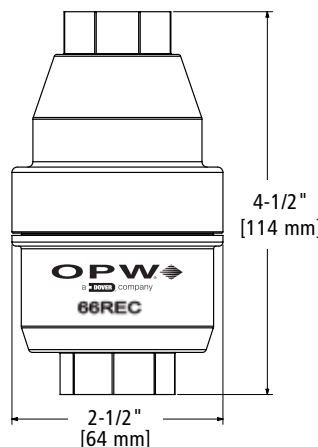

**Listings and
Certifications**



Materials

Body: Aluminum
Seals: Buna-N and Viton®
Weight: See matrix below



OPW 66V Series Breakaways

The OPW 66V Series Breakaways are designed and rigorously tested for use in today's fuels. Installed on fuel-dispensing hoses, they will separate at the designed pull force, reducing expensive damage to the dispenser and piping system. Internal dual valves close automatically during separation, stopping the flow of fuel from both the dispenser and the separated hose, reducing environmental and health risks of potential spilled fuel.

Features

- ◆ UL and ULc-listed for use in gasoline, diesel and up to 10% ethanol blends. Specific listings available at www.opwglobal.com.
- ◆ Prevents Costly Damage to Dispensers – pulls apart at less the designed pull force during drive-offs.
- ◆ Certainty of Operation – designed for single-use, so you know it is replaced instead of re-assembled.
- ◆ Prevents Hazardous and Costly Clean Up – unique double-poppet design closes leak path from both dispenser and separated hose side.

Design working pressure

- ◆ 50 psi (3.45 bar) maximum pressure.

NOTE: OPW 66V Series Breakaways must always be installed with a "straightening" hose with a minimum length of 9" for the 3/4" Series and a minimum length of 12" for the 1" Series, such as the 66H Series hoses.

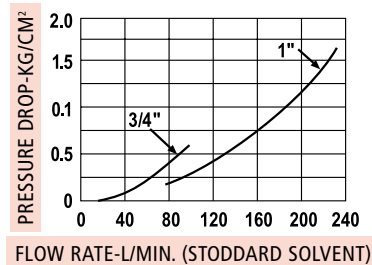
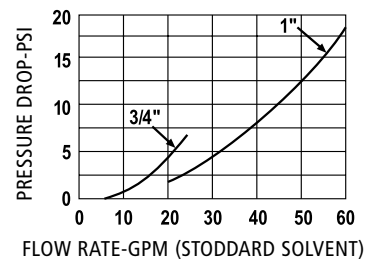

66V Series 3/4" Instruction Sheet Order Number: H10993PA
 66V Series 1" Instruction Sheet Order Number: H10993PA
 66S Series Instruction Sheet Order Number: H11015PA

Ordering Specifications

Product #	Connection Size		Weight		Description - Pull Force
	in.	mm	lbs.	kg	
66V-0300	3/4" F x 3/4" F (NPT)	19 F x 19 F	0.60	0.27	Valve / Single-Use Breakaway, 300 lb.
66V-030RF**	3/4" F x 3/4" F (NPT)	19 F x 19 F	0.60	0.27	Valve / Single-Use Breakaway, 300 lb.
66V-0492*	3/4" F x 3/4" F (NPT)	19 F x 19 F	0.60	0.27	Valve for up to E85 / Single-Use Breakaway/ 300 lb.
66V-1300	1" F x 1" F (NPT)	25 F x 25 F	0.98	0.45	Valve / Single-Use Breakaway/ 300 lb.
66V-130RF***	1" F x 1" F (NPT)	25 F x 25 F	0.98	0.45	Valve / Single-Use Breakaway/ 300 lb.
66V-1350	1" F x 1" F (NPT)	25 F x 25 F	0.98	0.45	Valve / Single-Use Breakaway/ 350 lb.
66V-135RF***	1" F x 1" F (NPT)	25 F x 25 F	0.98	0.45	Valve / Single-Use Breakaway/ 350 lb.

* 66V-0492 is UL-listed for up to 85% Ethanol
 ** 66V-030RF is UL-listed for up to 25% Ethanol and 20% Biodiesel
 *** 66V-130RF and 66V-135RF are UL-listed for up to 20% Biodiesel

Accessories

Product #	Connection Size	Length	Weight	Description
		in.	lbs.	
66-0075	3/4" F x 3/4" M (NPT)	19 F x 19 M	1.46	Valve w/ 9" Hose / No More Than 300 lb.
66-1300	1" F x 1" M (NPT)	25 F x 25 M	2.50	Valve w/ 12" Hose / Maximum 300 lb.
66S-0075	3/4"	19	0.20	Black Vinyl Scuff Guard Cover
66S-1300	1"	25	0.20	Black Vinyl Scuff Guard Cover

Listings and Certifications



66H Series of Hoses

The 66H Series Hoses are UL-approved, steel-reinforced hardwall flexible to -40°F. with 3/4-inch inside diameter with 3/4 inch male NPT chrome crimped ends. Compatible with fuel blends up to E15 and B20. Maximum working pressure of 50PSI. Also available in low-permeation per UL330.



Ordering Specifications

Product #	Length	Connection Size		Weight		Description
		in.	mm	lbs.	kg	
66H-0975	9 inch (23 cm)	3/4" M x 3/4" M (NPT)	19 M x 19 M	0.75	0.34	Straightening Hose
66H-0975-LP	9 inch (23 cm)	3/4" M x 3/4" M (NPT)	19 M x 19 M	0.75	0.34	Straightening Hose LOW PERMEATION per UL330
66H-1300	12 inch (30 cm)	1" M x 1" M (NPT)	25 M x 25 M	1.40	0.63	Straightening Hose
66H-08575	8.5 feet (2.6 m)	3/4" M x 3/4" M (NPT)	19 M x 19 M	4	1.8	Curb Hose
66H-08575-LP	8.5 feet (2.6 m)	3/4" M x 3/4" M (NPT)	19 M x 19 M	4	1.8	Curb Hose LOW PERMEATION per UL330

We don't stop at the nozzle.
We've got you covered with swivels, breakaways and hoses.

OPW Swivel Compatibility



Model	36S	241TPS	45
Up to E10	36S-5080	241TPS-0241	45-5060
Up to E25		241TPS-75RF	
Up to E85		241TPS-0492	
Up to B5	36S-5080 36S-5090	241TPS-0241 241TPS-1000	45-5060 45-5075
Up to B20		3/4" 241TPS-75RF 1" 241TPS-10RF	

OPW Breakaway Compatibility



Now Approved
 For E25,
 Ethanol Blend



Model	66V	68EZR	66REC	66SB
Up to E10	66V-0300	68EZR-7575	66REC-1000	66SB-7575 66SB-1010
Up to E25	66V-030RF	68EZR-75RF		
Up to E85	66V-0492			
Up to B5	66V-0300 66V-1300 66V-1350	68EZR-7575 68EZR-1010	66REC-1000	66SB-7575 66SB-1010
Up to B20	3/4" 66V-030RF 1" 66V-130RF 1" 66V-135RF	68EZR-75RF 68EZR-10RF		

Hose Compatibility



Straightening Hose:
 66H-0975 - 9 inch (23 cm)



Curb Hose:
 66H-08575
 8.5 foot (2.6 m)

Model	Whip Hose (9 in)	Curb Hose (8.5 ft)
Up to E10	66H-0975	66H-08575
Up to E25	66H-0975-E25	66H-08575-E25
Up to E85	66H-0975-E85	66H-08575-E85
Up to B5	66H-0975	66H-08575
Up to B20	66H-0975	66H-08575
Low Perm	66H-0975-LP	66H-08575-LP



E25, B20
Hose Kits Available
 Contact Your OPW Distributor
 or Sales Representative

Materials

- Body:** Aluminum nickel-plated
- Spring:** Steel zinc-plated
- Guide:** Ceramic-filled plastic
- Adaptor:** Steel zinc-plated
- Inlet and Outlet Size:** 3/4" NPT



44-0044

44N-1044

Features

- ◆ UL and ULC-listed for use in gasoline, diesel and up to 10% ethanol blends. Specific listings available at www.opwglobal.com.
- ◆ Compact, attractive profile – for a sleek, modern appearance.
- ◆ Includes a 3/4" NPT pipe nipple.
- ◆ The OPW 44-0044 is designed to be installed at the dispenser outlet or between the dispenser and the

breakaway valve, thus removing it from the abusive action sometimes seen at the nozzle.

- ◆ A flow-indication arrow – is indicated on the flow limiter for easy installation.

Design working pressure

- ◆ 50 psi (3.45 bar) maximum pressure.

OPW 44 Flow Limiters

The OPW 44 Flow Limiters allow your customers to comply with the EPA's 10-gallon maximum flow-rate mandate which went into effect July 1, 1996. The OPW 44-0044 Flow Limiter is designed to control the maximum fuel flow rate to 10 gpm.

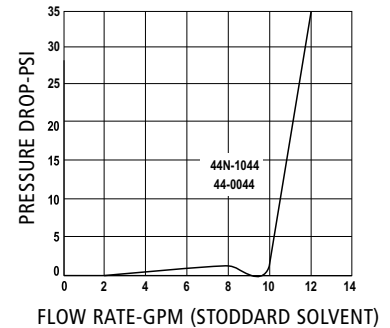

44-0044

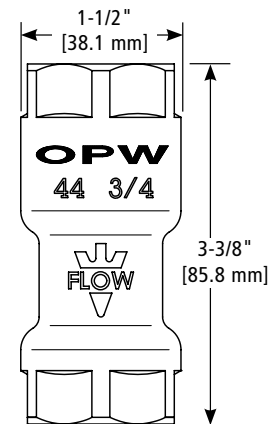

Ordering Specifications

Product #	Length		Weight	
	in.		lbs	kg
44-0044	3/4 F x 3/4 F (NPT)		1.2	.54

44 Series Instruction Sheet Order Number: **H12918PA**

NOTE: See OPW's Website at opwretailfueling.com for product instruction sheets, troubleshooting guides, how-to-use guide and to view the Do's & Don'ts at the Gas Pump video.

Listings and Certifications



See pages 258 - 266 for certification number

Vacuum-Assist Vapor Recovery Hanging Hardware



- 12VW Nozzles..... 169
- Vapor Recovery Nozzle Accessories & Replacement Parts 170
- Hose Swivels..... 171
- Reconnectable Swivel & Breakaways 172
- Dry-Reconnect Inverted Breakaways 173

Materials

Body: Aluminum
Lever & Lever Guard: Duratuff®
Packing: Graphite with Teflon®
Disc: Viton®
Spout: Aluminum w/Stainless-Steel tip
Inlet Size: M34 Metric
Weight: 3.1 lbs. each; 31.0 lbs./case of 10
 1.41 kg each; 14.1 kg/case of 10



12VW

Features

Safe for Use

- ◆ UL-listed for use in gasoline, diesel and up to 10% ethanol blends. Specific listings available at www.opwglobal.com.
- ◆ Prevents gasoline spills in prepay or card-lock systems utilizing OPW's unique No-Pressure - No-Flow Device. – The nozzle cannot be opened until the pumping system is pressurized and closes automatically when the pressure is removed.
- ◆ Prevents consumer from jamming the nozzle in an open position – blocker on lever guard.
- ◆ Vapor Escape Guard (VEG) improves vapor collection.
- ◆ Lever-activated vapor valve only opens when product is flowing controlling the amount of vapors collected from the vehicle.

Durable and Long Lasting

- ◆ Cycle tested and proven to last longer than 1 million cycles – better than any other nozzle available on the market today*.

- ◆ Stainless-steel insert in spout to last longer than standard aluminum-only spouts.
- ◆ Durable lever guard that won't scratch your customers' vehicles – made from Duratuff®.
- ◆ New hold-open clip spring lasts longer than previous designs.
- ◆ Internal vapor path – no replacement parts needed.

Appealing to Customers

- ◆ Easy to use – utilizing Accu-Stop® to-the-penny Flow Control Technology.
- ◆ Attractive 2-Piece NEWGARD™ Hand Insulator is the most comfortable nozzle in the industry to use.
- ◆ Convenient – one-finger hold-open clip that is easy to set the flow rate (not on all models).

Design working pressure

- ◆ 50 psi (3.45 bar) maximum pressure.
- * OPW internal lab-testing results as of August 2010.**

OPW 12VW Vacuum-Assist Nozzles

The OPW 12VW Series automatic nozzles are one of OPW's premium nozzles for Vacuum-Assist vapor recovery systems. Designed with an integrated vapor valve, they are certified on the most used vapor recovery systems in the world. The 12VW is the most trusted vapor recovery nozzle in the world for the applications it is certified on including:

- Dresser/Wayne Wayne® Vac
- Gilbarco® VaporVac®
- Schlumberger
- Vacurite

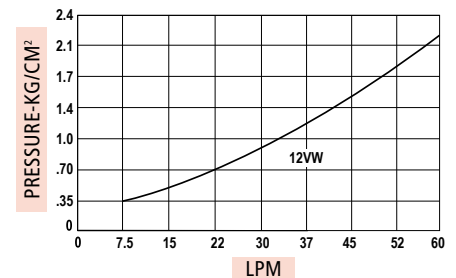
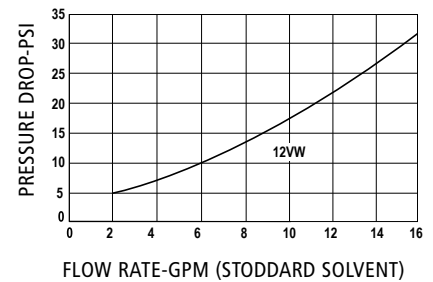

Listings and Certifications



CARB

California Air Resources Board

Listings and Certifications

Certifications and Listings

Gilbarco® VaporVac®

CARB Initial Certification Date	April 2000	July 2000
CARB Certification Number	G-70-153* / G-70-199**	G-70-150* / G-70-199**

* Latest version.

**Approval for 350ml liquid-retention requirement.

Ordering Specifications

Standard Hand Insulator Color	12VW New Unleaded, with Hold-open Rack	12VW w/ AdMaster™
Green	12VW-0100	
Silver	12VW-0200	
Red	12VW-0300	
Black	12VW-0400	12VW-0400-AD
Blue	12VW-0500	
Gold	12VW-0750	
Yellow	12VW-0900	
Bare	12VW-0000	

Replacement and Repair Parts

Product	Description	Part#
Spout Kit	Replacement aluminum unleaded spout with VEG	5VW-2000
ECD Kit	Replacement ECD and hardware	3VW-0450

12VW Series Instruction Sheet Order Number: H15890PAE

Typical Installation

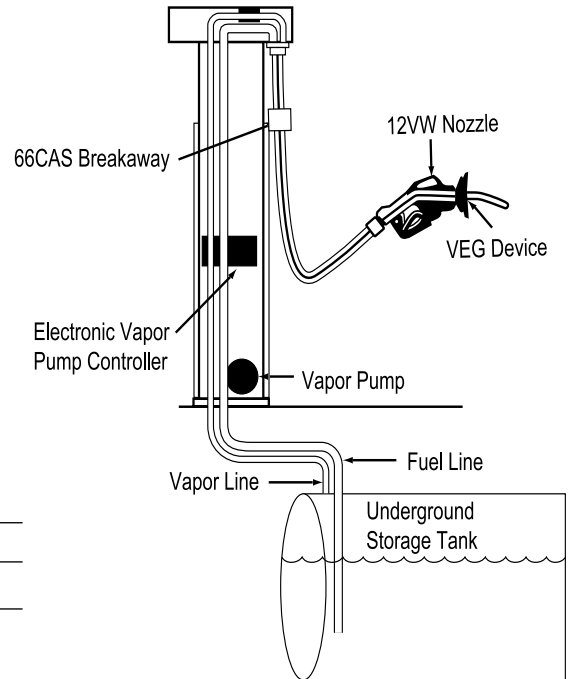

OPW 6 NEWGARD™ Two-Piece Hand Insulator

Ordering Specifications

Hand Insulator Color	12VW New Unleaded, with Hold-Open Rack
Green	H13964M
Silver	H14662M
Red	H13942M
Black	H13941M
Blue	H14580M
Gold	H14661M
Yellow	H13943M
Hand Insulator Barrel	D02141M



Materials

- Body:** Aluminum
- Outlet Adaptor:** Aluminum
- Inlet Adaptor:** Aluminum
- Seals:** Viton® and Buna-N
- Weight:** 1.5 lbs. each, 0.68 kg

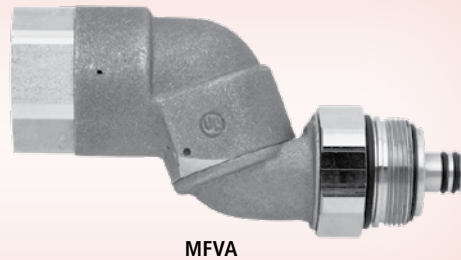

MFVA

Features

- ◆ **UL-listed** for use in gasoline, diesel and up to 10% ethanol blends. Specific listings available at www.opwglobal.com.
- ◆ **Easier Hose Movement** – filling the vehicle is much easier, because hoses do not kink and are much freer to move.
- ◆ **Improved Wear** – reduces stress and wear on hoses.
- ◆ **Two-Plane Rotation** – the first swivel plane allows for 360° of motion perpendicular to the axis of the nozzle.
- ◆ The second swivel plane allows for 360° of motion parallel to the axis of the nozzle for easy nozzle positioning in the fill pipe.
- ◆ **Compact, Attractive Profile** – provides a sleek, modern appearance, allowing hoses to hang straight down instead of at an angle.
- ◆ **Secure Design** – not repairable or rebuildable for certainty of operation. Every MFVA is factory assembled and tested.
- ◆ **Special Swivel Outlet Design** – male adaptor is specially designed so that tightening of the threaded joint will not inhibit swivel rotation.

Design working pressure

- ◆ 50 psi (3.45 bar) maximum pressure.

OPW MFVA Inverted Swivel

The OPW MFVA Inverted Swivel is designed for vapor recovery applications where easy nozzle and hose handling are important for customer convenience. When attached between the nozzle and the hose, the OPW MFVA two-plane swivel allows your customer a much fuller range of motion in positioning the nozzle to fill the vehicle. Your customer can access the fill pipe from virtually any angle with minimal effort. The OPW MFVA attaches between the hose and the nozzle to reduce strain, providing flexibility so fueling hoses last longer. The OPW MFVA provides 360° swivel action for easy nozzle positioning into the fill pipe.

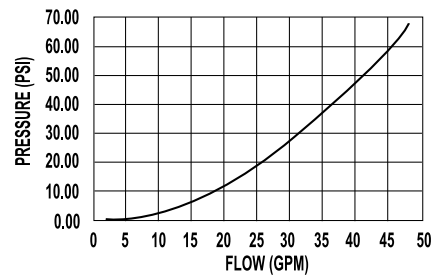
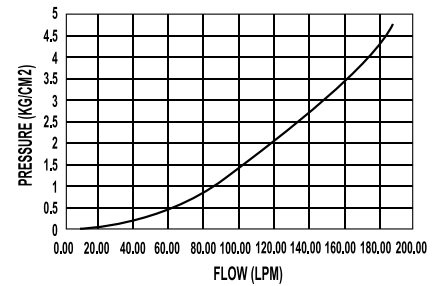

Ordering Specifications

Product #	Description	Threads
MFVA	Vacuum-Assist Swivel	M34 Metric

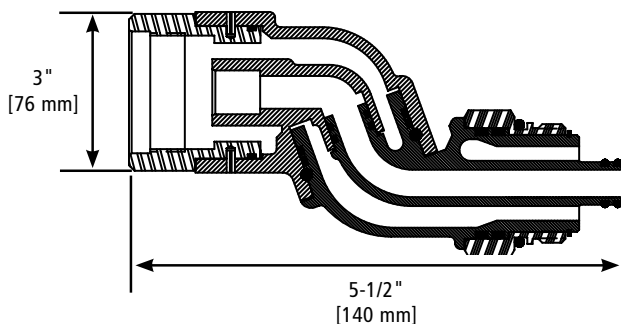

Listings and Certifications



CARB

California Air Resources Board

OPW 66ISB Vacuum-Assist Stage II Vapor Recovery Reconnectable Swivel/Breakaways

Reconnectable, vapor-poppeted Vacuum-Assist Swivel/Breakaways available. Designed for those who want to provide customers with the convenience of a 2-plane swivel and the added safety of a breakaway.

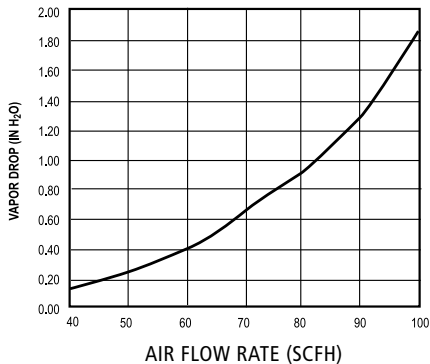

Materials

- Body: Aluminum
- Sleeve: Nylon, HDPE
- Seals: Viton®
- Spring: Stainless-steel
- Poppet: Aluminum
- Weight: 1.3 lbs., 0.60 kg



66ISB-5100

Features

- ◆ UL and ULc-listed for use in gasoline, diesel and up to 10% ethanol blends. Specific listings available at www.opwglobal.com.
- ◆ Breakaway separates at 350 pounds of axial force.
- ◆ 66ISB-5100 comes with vapor poppet.
- ◆ Swivel rotation of 360° in both planes.
- ◆ Push-back reconnect style.
- ◆ Easier reconnection at waist height.
- ◆ Extends hose life.
- ◆ Double O-rings at each joint.

Design working pressure

- ◆ 50 psi (3.45 bar) maximum pressure.

Ordering Specifications

Product #	Threads
66ISB-5100	M34 Metric Breakaway

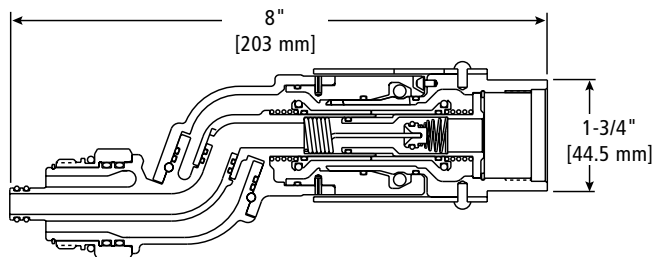

Listings and Certifications



California Air Resources Board

CARB Certified and UL-listed Per Standard 567.

Materials

- Body:** Aluminum
- Main Seals:** Viton®
- Guide and Poppets:** Acetal
- Protective Sleeves:** Impact-Resistant Nylon®
- Main Spring:** Stainless-steel
- Weight:** 1.0 lbs., 0.45 kg



66CAS-0300

Features

- ◆ UL-listed for use in gasoline, diesel and up to 10% ethanol blends. Specific listings available at www.opwglobal.com.
- ◆ Dual Poppets – close to prevent product spillage and vapor leakage.
- ◆ Dual-poppeted breakaways are recommended for use in any vacuum-assist systems, especially nozzles with integral vapor valves.
- ◆ Sleek, Attractive Appearance – to enhance station image.
- ◆ Quick Reconnect – requires only 15 lbs. of force to reconnect.
- ◆ Dry-Reconnect – designed to help prevent liquid from spraying the operator during the reconnection operation.
- ◆ Rugged, Durable Construction – outer sleeve to protect coupling and sealing parts from damage for long, trouble-free service life.

- ◆ Nozzle and Hose Compatibility – interfaces with Stage II vapor recovery nozzles by OPW, and with all manufacturers of vapor recovery hoses (features the popular M34 metric thread).

Construction/Design

- ◆ Outer sleeve to protect sealing and coupling parts in a drive-away.
- ◆ Field-proven, double-poppet design that seals both ends of the product line and the dispenser side of the vapor line in a drive-away.
- ◆ Inverted metric coaxial hose fitting for installation into any vacuum-assist dispenser.
- ◆ Easily replaces any inverted breakaway currently in use today.

Design working pressure

- ◆ 50 psi (3.45 bar) maximum pressure.

OPW 66CAS Dry-Reconnect Inverted Breakaways

The OPW 66CAS Dual-Poppeted, Dry-Reconnect Inverted Breakaway is designed to close off the liquid path and the vapor path in the event of a drive-away. Engineered to separate at a maximum of 300 pounds of axial pull force, the OPW 66CAS Breakaway is also designed to handle line shock better than a single-use breakaway, while protecting your dispensing system from catastrophic damage. The OPW 66CAS is developed for use with inverted coaxial metric hoses and designed to meet today's demanding standards.

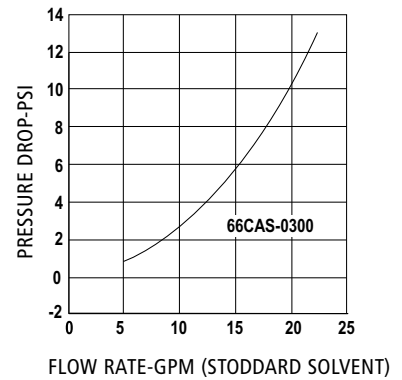

Ordering Specifications

Product #	Threads
66CAS-0300	M34 Metric Breakaway

66CAS Series Instruction Sheet
Order Number: H13008M

Replacement Parts

Product #	Threads
66SRK-1000	Seal Replacement Kit

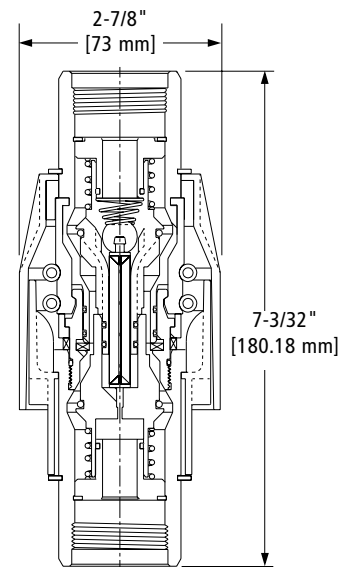

Listings and Certifications



CARB

California Air Resources Board

Balance Vapor Recovery Hanging Hardware



- Reconnectable Breakaways 175-176

Materials

Body: Aluminum
Seals: Buna-N
Weight: 0.75 lbs.,
 0.34 kg



VAR75

Features

- ◆ Lightweight, maintenance-free and easy to install.
- ◆ Adapts M-34 thread to a 3/4" NPT thread.

Design working pressure

- ◆ 50 psi (3.45 bar) maximum pressure.

Ordering Specifications

Part No.	Description
VAR75	Vac-assist to 3/4" NPT Conventional Converter

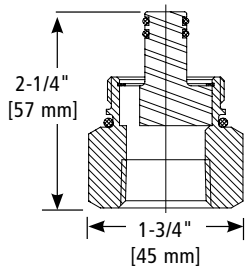

Materials

Body: Aluminum
Seals: Buna-N
Weight: 0.75 lbs.,
 0.34 kg



28C

Features

- ◆ Lightweight, maintenance-free and easy to install.
- ◆ Adapts 1-7/8 – 12 UN thread to a 3/4" NPT thread

Design working pressure

- ◆ 50 psi (3.45 bar) maximum pressure.

Ordering Specifications

Part No.	Description
28C-0028	Coax Vapor Recovery x 3/4" NPT Bushing

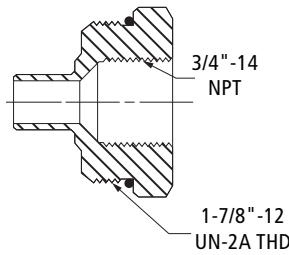

**OPW VAR75 Converter
 Vac-Assist to 3/4" NPT**

Converts vacuum-assist nozzle to a conventional hose or a vacuum-assist dispenser for use with a conventional hose.

**OPW 28C Balance
 Coax Adaptor**

The OPW Balance Adaptor is designed to convert Balance Coax dispensers into a conventional hose point. Simply remove the existing balance hose and thread the 28C into the existing dispenser, then thread in your new conventional hose.

Materials

- Body:** Die-cast zinc
- Protective Sleeves:** Impact-modified nylon
- Main Seals:** Viton®
- Main Spring:** Stainless-steel
- Guide and Poppets:** Acetal
- Weight:** 0.97 lbs., 0.44 kg

66CLP-5100



OPW 66CLP Balance Phase II Enhanced Vapor Recovery Reconnectable Breakaway

For more than a decade, the 66CLP has earned the reputation as the industry standard in preventing fuel vapors from escaping during a separation incident on balance systems. Its proven design minimizes downtime and allows all hose points to be put back in service as quickly and easily as possible after a separation event. The OPW 66CLP is also approved for VST Phase II Enhanced Vapor Recovery Systems.

Features

- ◆ UL-listed for use in gasoline, diesel and up to 10% ethanol blends. Specific listings available at www.opwglobal.com.
- ◆ Separates at 350 pounds of axial force.
- ◆ Push-back reconnect style.
- ◆ Durable, lightweight construction.
- ◆ Minimal pressure drop.

Design working pressure

- ◆ 50 psi (3.45 bar) maximum pressure.

Ordering Specifications

Product #	Description
66CLP-5100	Vapor Poppeted Reconnectable Balance Breakaway
66CLP Instruction Sheet Order Number: F-70	

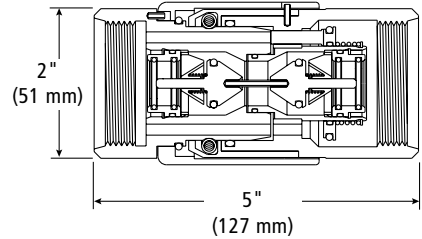

Replacement Parts

Product #	Description
204870	O-ring
204872	Spring
204811	Outer Cover

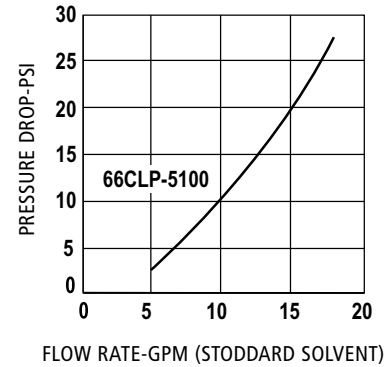

Listings and Certifications

CARB Certification Numbers	Executive Order VR-203-N (for Balance Phase II Enhanced Vapor Recovery (EVR) Systems Not Including In-Station Diagnostics (ISD))
	Executive Order VR-204-N (for Balance Phase II Enhanced Vapor Recovery (EVR) Systems Including In-Station Diagnostics (ISD) Systems)

Listings and Certifications



CARB
California Air Resources Board

Industrial Products



- DEF Bulk Nozzle..... 178
- Automatic Nozzles..... 179
- Overwing Aircraft Nozzles 180 - 183
- Manual High-Flow Bulk-Fill Nozzles 184 - 188
- Manual Nozzle Accessories..... 189
- Manual Utility Farm Nozzle 190
- Reconnectable Breakaways 191
- Hose Swivels..... 192



OPW 19DEF Series Industrial Automatic Nozzle

When you're responsible for ensuring the safe, reliable and affordable dispensing of Diesel Exhaust Fluid (DEF) for on-road, off-road, commercial and industrial heavy-duty trucks, farming or other diesel-powered vehicles, you rely on the most trusted name in dispensing nozzles – OPW.

The NEW OPW 19DEF Series Industrial Automatic Nozzle is specifically designed for your commercial and industrial fleet operations, offering unmatched reliability with the features you want.

OPW 19DEF Series Swivels

Reconnectable Swivel Breakaway



- Designed to connect to the inlet of the nozzle. - No whip hose needed
- The industry's best swiveling ability
- Breakaway is reconnectable with built in swivel; retaining jaws and seals are replaceable
- Breakaway will separate at no more than 350 pounds of force. (axial or angular)

Swivel



- The industry's best swiveling ability

Design Working Pressure

- ◆ 50 PSI (3.45 bar) maximum pressure

NOTE: The OPW 19DEF Equipment is for commercial-fleet applications only and is not UL-listed for gasoline-dispensing facilities.

Materials

- Packing & Disc:** Fluorocarbon
- Lever & Lever Guard:** Duratuff®
- Spout:** Stainless-Steel
O.D. 19mm (0.75 in) per ISO 22241 Specifications
- Inlet Size:** 3/4" NPT or 3/4" BSPP
- Weight:** 2.73 lbs. each, 43.1 lbs./case of 15, 1.25 kg each, 19.9 kg/case of 15



Features - Benefits

- ◆ Stainless-Steel Spout – provides optimum DEF purity and prevents corrosion
- ◆ Lowest Overall Cost of Ownership – reliable, long-lasting design based on proven OPW quality platform and industry standard-setting technology
- ◆ Ease of Use – sleek, lightweight design with patented Accu-Stop® Flow Control Technology and convenient one-finger hold-open clip to set flow rate
- ◆ User Comfort – attractive 2-Piece NEWGARD™ Hand Insulator is the most comfortable nozzle in the industry in hot or cold weather
- ◆ Vehicle Protection – our Duratuff® lever guard not only provides for rugged durability when dropped but also won't scratch your fleet vehicle
- ◆ Meets ISO 22241 Requirements – all materials of construction are 100% third-party tested and approved for DEF compatibility

Product #	Description
Nozzles	
19DEF-0500SS	Nozzle, DEF - 3/4" Female NPT inlet, for use WITHOUT Mis-Filling Prevention Device
19DEF-050LSS	Nozzle, DEF - 3/4" Female BSPP inlet, for use WITHOUT Mis-Filling Prevention Device
19DEFM-0500SS	Nozzle, DEF - 3/4" Female NPT inlet, for use WITH Mis-Filling Prevention Device
19DEFM-050LSS	Nozzle, DEF - 3/4" Female BSPP inlet, for use WITH Mis-Filling Prevention Device
Swivel Breakaway	
19DB-0075	Breakaway, DEF, 3/4" NPT
19DB-0075L	Breakaway, DEF, 3/4" BSPP
Hose Swivel	
19DHS-0075	Hose Swivel, DEF, 3/4" NPT
19DHS-0075L	Hose Swivel, DEF, 3/4" BSPP
Swivel	
19DS-0075	Swivel, DEF, 3/4" NPT
19DS-0075L	Swivel, DEF, 3/4" BSPP
Hose Adaptors	
19DM-0100	3/4" MNPT to 1" MNPT - Connecting nozzle to 1" NPT Female hose
19DF-0100	3/4" MNPT to 1" FNPT - Connecting nozzle to 1" NPT Male hose
19DML-0100	3/4" MBSPP to 1" MBSPP - Connecting nozzle to 1" BSPP Female hose
19DFL-0100	3/4" MBSPP to 1" FBSPP - Connecting nozzle to 1" BSPP Male hose
19DML-0075	3/4" MBSPP to 3/4" MBSPP - Connecting nozzle to 3/4" BSPP Female hose
205899	1" Male BSPP Adaptor
205900	1" Female NPT Adaptor

OPW 1291C Automatic Shut-Off Nozzles

For Heavy-Duty, High-Flow Truck, Bus and Home Fuel Oil Delivery Service

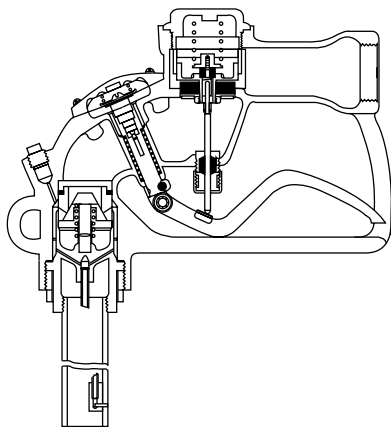
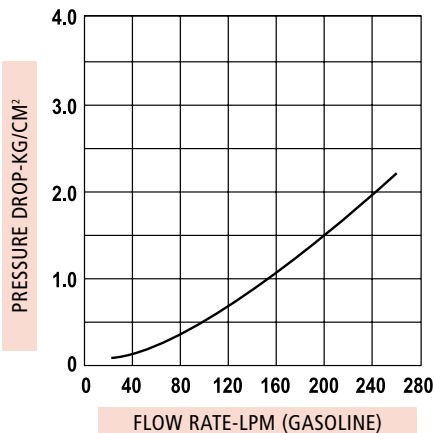
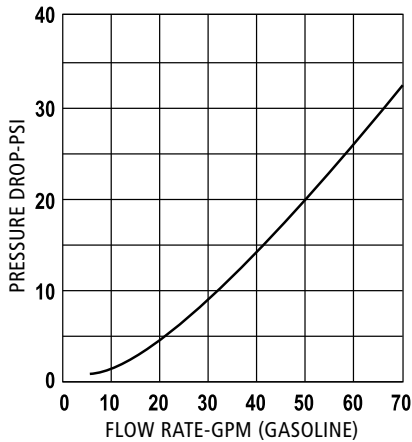

Materials

- Body: Aluminum
- Main stem: Stainless-steel
- Packing: Graphite with Teflon®
- Main Disc: Viton®
- Inlet Size: 1-1/2" NPT



1291C-0050

Features

- ◆ Venturi-Type Shut-Off Mechanism – for automatic shut off.
- ◆ Aluminum Body – lighter in weight and easier to maneuver than other nozzles on the market.
- ◆ Two-position hold-open device*.
- ◆ One-Hand Control of Hold-Open Mechanism – means easy setting of flow rate.
- ◆ Right-Angle Design – provides larger lever area for better grips and easier control, permitting the nozzle to fit into awkward spaces close to walls and into corners.
- ◆ Easy Spout Replacement – simply remove the spout's retainer nut.
- ◆ Built-In Outlet Check Valve – meets all known requirements of the Division of Measurement Standards.
- ◆ Dual Poppets – make nozzle easy to open against high inlet pressure.

Design working pressure

- ◆ 50 psi (3.45 bar) maximum pressure.
- ◆ Service Temperature range: -20° F to 140° F (-29°C to 60°C)

Ordering Specifications

Product #	Description	Inlet Thread			
		in.	mm	lbs.	kg
1290-0050	New	1 1/2"	38	6.8	3.1
1291C-0050*	New	1 1/2"	38	6.8	3.1
1290G-0050	New	1 1/2"	38	6.8	3.1

Government National Stock #s:
 1290-0050; NSN 4930-01-290-0756
 1290G-0050; NSN 4930-01-352-1660 green anodized
 1290GS-0050; NSN 4930-01-352-1661 tan anodized
 (1290GS-AR50; tan anodized without Kamlok coupler and dust plug)

Replacement Spout

Product #	Description	O.D.		Length		Weight	
		in.	mm	in.	mm	lbs.	kg
5D-0125	8-1/2", 1290, Spout Kit	1 3/8"	35	8 1/2"	215	1.5	0.68
5D-0126C	8-1/2", 1291C, Spout Kit	1 3/8"	35	8 1/2"	215	1.5	0.68

1290 Series Instruction Sheet Order Number: H09238PA

Listings and Certifications



***1291C Nozzles are not permitted and sold with Hold-Open Clips per ULc S620 requirements.**

Materials

- Body:** Cast aluminum
- Main Stem:** Stainless-steel
- Stem Seal:** Buna-N O-Ring
- Disc:** Viton®
- Spout:** Aluminum

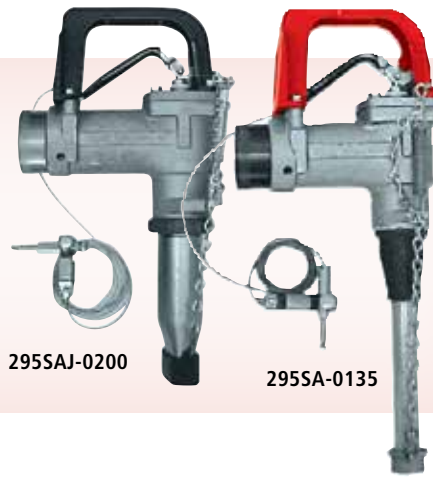

Features

- ◆ Aluminum Body – lighter weight, easier to maneuver.
- ◆ Dual Poppets – easy-to-open nozzle against high inlet pressures.
- ◆ Color-Coded Composite Lever Guards – helps distinguish between AVGAS and Jet A. Easily replaced in lever-guard kit.
- ◆ Right-Angle Design – provides larger lever area for better grip and easier control.
- ◆ Vinyl-Coated Lever – insulates fingers against cold.
- ◆ 100-Mesh Strainer – prevents foreign matter from entering fuel tank; easy to remove and clean.
- ◆ Dust Cap – keeps spout free from dirt and stops fuel drippage when connected.
- ◆ Adjustable Dash Pot – permits adjusting the main poppet closure rate over a wide range of flows to overcome line shock with minimum afterflow.
- ◆ Easy Spout Replacement – the spout is easily threaded into the body. Replacement spouts are readily available from OPW.
- ◆ Built-In Swivel – eliminates twisting and kinking of the hose. This swivel is electroless nickel-plated and has full-bearing surfaces.
- ◆ NPT Female Threads at Inlet End of 295SA – accepts all 1", 1-1/4" or 1-1/2" male connections.
- ◆ NPT Female Threads At Inlet End Of 295SAJ – accepts all 1-1/2" male connections.
- ◆ Unique Jet Aircraft Spout Design of 295SAJ – to help prevent inadvertent fueling of piston-engine aircraft with turbine fuel.
- ◆ Ground-Wire Assembly – included on all aviation nozzles.

Design working pressure

- ◆ 110 psi (7.58 bar) maximum pressure

Level Guard Replacement Kits

Product #	Nozzle
295KLG-0300	295SA-0135, 0136, 0137, 295SAC-0156, 0157 Red
295KLG-0350	295SA-0138, 275SAC-0158 Red
295KLG-0400	295SAJ-0200, 295SACJ-0200 Black

All lever-guard kits include new lever sub-assembly.
295 Series Instruction Sheet Order Number: **H09237PA**

Manual Overwing Aircraft Nozzles

295SA – AVGAS

295SAJ – Jet Fuel

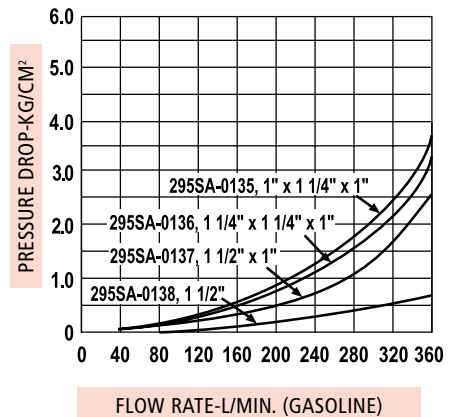
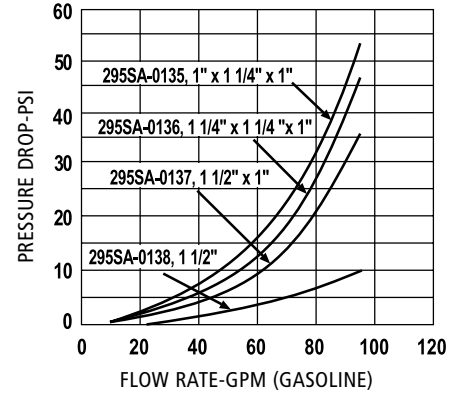

Ordering Specifications

Product #	Inlet Thread		Spout O.D			
	in.	mm	lbs.	kg	in.	mm
295SA-0135	1	25	4.60	2.10	1	25
295SA-0136	1/4	32	4.50	2.00	1	25
295SA-0137	1/2	38	4.50	2.00	1	25
295SA-0138	1/2	38	5.10	2.30	1 5/8	41
295SAJ-0200	1/2	38	5.60	2.50	2 2/3	67
295SAC-0156*	1/4	32	4.50	2.00	1	25
295SAC-0157*	1/2	38	4.50	2.00	1	25
295SAC-0158*	1/2	38	5.15	2.30	1 5/8	41
295SACJ-0200*	1/2	38	5.65	2.60	2 2/3	67

*Check Valve

NOTE: See OPW's Website at www.opwglobal.com for product instruction sheets, troubleshooting guides, how-to-use guide and to view the Do's & Don'ts at the Gas Pump video.

Replacement Parts - OPW 295SA/295SAC & 295SAJ

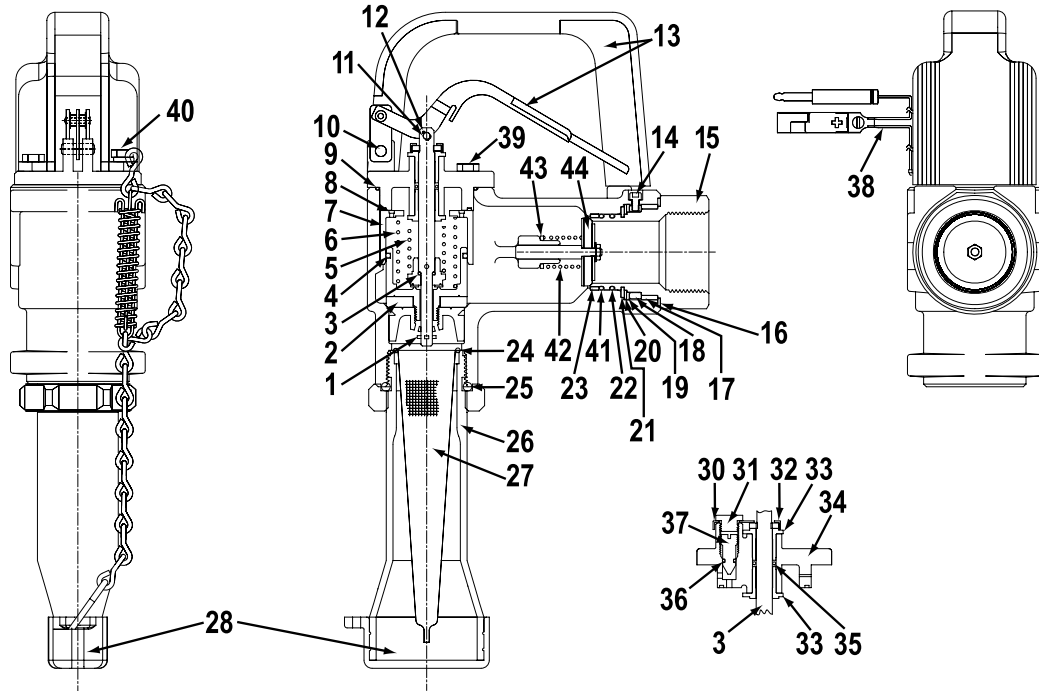

Key	Part #	Description	295SA-0135 inlet/ spout 1" x 1"	295SA-0136 & 295SAC- 0156 inlet/spout 1 1/2" x 1"	295SA-0137 & 295SAC- 0157 inlet/spout 1 1/2" x 1"	295SA-0138 & 295SAC- 0158 inlet/spout 1 1/2" x 1 1/2"	295SAJ-0200 & 295SACJ-0200 inlet/ spout 1 1/2" x 1 1/2"
1	H02477M	Cotter Pin	•	•	•	•	•
2	H07719	Main Poppet S/A	•	•	•	•	•
3	H09420	Stem & Sec. Poppet				•	•
3	H09417	Stem & Sec. Poppet	•	•	•		
4	H12706M	O-Ring	•	•	•	•	•
5	H09367M	Spring	•	•	•	•	•
6	H05064M	Spring	•	•	•	•	•
7	H05088M	Skirt	•	•	•	•	•
8	H05198M	Seal	•	•	•	•	•
9	H04828M	Seal	•	•	•	•	•
10	H03981RE	Pin	•	•	•	•	•
11	215290	Cotter Pin	•	•	•	•	•
12	H07580M	Rivet	•	•	•	•	•
13	295KLG-0300	Lever Guard Kit	•	•	•		
13	295KLG-0350	Lever Guard Kit				•	
13	295KLG-0400	Lever Guard Kit					•
14	H13774M	Screw (3 req'd)	•	•	•	•	•
15	295SWK-0007	Swivel Repair Kit	•				
15	295SWK-0009	Swivel Repair Kit		•			
15	295SWK-0014	Swivel Repair Kit				•	•
15	295SWK-0013	Swivel Repair Kit			•		
16	H08886M	Dust Seal				•	•
16	H01227M	Dust Seal	•	•	•		
17	H08887M	Bearing				•	•
17	H08879M	Bearing	•	•	•		
18	H09713RS	Retainer				•	•
18	H09712RS	Retainer	•	•	•		

Replacement Parts-OPW 295SA/SAC & SAJ Aircraft Nozzles

Key	Part #	Description	295SA-0135 inlet/ spout 1" x 1"	295SA-0136 & 295SAC- 0156 inlet/spout 1 1/2" x 1"	295SA-0137 & 295SAC- 0157 inlet/spout 1 1/2" x 1"	295SA-0138 & 295SAC- 0158 inlet/spout 1 1/2" x 1 1/2"	295SAJ-0200 & 295SACJ- 0200 inlet/spout 1 1/2" x 1 1/2"
19	H08881M	Thrust Bearing	•	•	•		
19	H08889M	Thrust Bearing				•	•
20	H08882M	Lock Ring	•	•	•		
20	H08890M	Lock Ring				•	•
21	H09365M	Retaining Ring	•	•	•		
21	H09366M	Retaining Ring				•	•
22	H12319M	O-Ring, Buna-N	•	•	•		
22	H12320M	O-Ring, Buna-N				•	•
23	H08884M	Bearing	•	•	•		
23	H08892M	Bearing				•	•
24	H06026M	O-Ring	•	•	•		
24	H07670M	O-Ring				•	
24	H11499M	O-Ring					•
25	H05297M	O-Ring	•	•	•		
25	H07766M	O-Ring				•	
25	H10458M	O-Ring					•
26	297SA-9050	Spout S/A	•	•	•		
26	297SA-9060	Spout S/A				•	
26	696J-7010	Spout S/A					•
27	190S-7063	Strainer	•	•	•		
27	153-0910	Strainer				•	
27	153J-0100	Strainer					•
28	H10387	Cap & Chain S/A	•	•	•		
28	H10388	Cap & Chain S/A				•	
28	296CJ-0100	Cap & Chain S/A					•
29	H09212	Body Cap S/A**	•	•	•		
29	H09213	Body Cap S/A**				•	•
30	H05135M	Retainer	•	•	•	•	•
31	H08441RS	Screw	•	•	•	•	•
32	H05087M	Felt Wiper	•	•	•	•	•
33	H05063M	Bushing	•	•	•	•	•
34	C02115A	Cap	•	•	•		
34	C02117A	Cap				•	•
35	H12707M	O-Ring	•	•	•	•	•
36	H12705M	O-Ring	•	•	•	•	•
37	H04825M	Adj. Screw	•	•	•	•	•
38	190WM-8001	Ground Wire S/A	•	•	•	•	•
39	H07062M	Screw (4 req'd)	•	•	•	•	•
40	H06045M	Screws (2 req'd)	•	•	•	•	•
41	H13776M	O-Ring, Viton®				•	•
41	H13775M	O-Ring, Viton®	•	•	•		

** Body Cap sub-assembly includes parts 30-37.

Replacement Parts - OPW 295SAC & 295SACJ Only

Key	Part #	Description	295SAC-0156	295SAC-0157	295SAC-0158	295SACJ-0200
42	H07595M	Spring SST	•	•		
42	H07593M	Spring SST			•	•
43	H07613M	Washer, nylon	•	•	•	•
44	H09214	Poppet S/A	•	•		
44	H09215	Poppet S/A			•	•

OPW 295AF Manual Aircraft Nozzles

For Overwing Aircraft Service

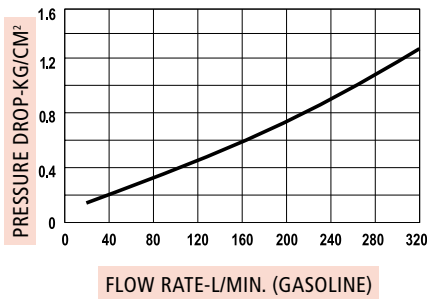
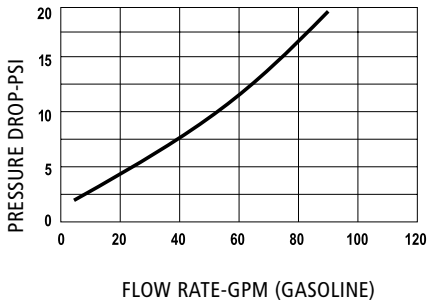

Replacement Parts

Part #	Description
153AF-0100	100-Mesh Strainer
190WF-8002	Ground Wire S/A w/ Dust Cap
C03420NM	Protector Ring
C03422	Dust Cap
297AF-9070	1 1/2" Aluminum Spout for 295AF
E00274AG	Arctic Guard for 295AF

Materials

- Body:** Cast aluminum
- Main Stem:** Stainless-steel
- Stem Seal:** Buna-N O-Ring
- Main Poppet Disc:** Viton®
- Spout:** 297AF-9070



Features

- ◆ Aluminum Body – lighter weight, easier to maneuver.
- ◆ Dual Poppets – easy-to-open nozzle against high inlet pressures.
- ◆ Replaceable Lever Guard – easy, low-cost replacement.
- ◆ Right-Angle Design – provides larger lever area for better grip and easier control.
- ◆ Vinyl-Coated Lever – insulates fingers against cold.
- ◆ 100-Mesh Strainer – prevents foreign matter from entering fuel tank; easy to remove and clean.
- ◆ Dust Cap – keeps spout free from dirt and stops fuel drippage when connected.
- ◆ Spout-Protector Ring – to protect aircraft tanks and wing surface; adjustable. Furnished as standard.
- ◆ Special Heavy-Duty Spout – knurled to facilitate daily strainer service.
- ◆ NPT Female Threads at Inlet End – standard pipe threads all 1-1/2" male connections.
- ◆ Static Ground Wire – with air-force plug meets MS 25384-5.
- ◆ Dash-Pot Action – for smoother closing action and reduced line shock.

Design working pressure

- ◆ 110 psi (7.58 bar) maximum pressure

Ordering Specifications

Product #	Inlet Thread			
	in.	mm	lbs.	kg
295AF-0100	1 1/2"	38	6.40	2.90

Gov't. Nat'l. Stock #: 4930-01-293-4472
 295 Series Instruction Sheet Order Number: **H09237PA**

Materials

- Body:** Cast aluminum
- Main Stem:** Stainless-steel
- Stem Seal:** Graphite with Teflon®
- Disc:** Viton®
- Spout:** OPW 296 brass or 297 aluminum (optional)



190-0115
(Spout optional, see Page 190)

Features

- ◆ Aluminum Body – lighter weight, easier to maneuver.
- ◆ Dual Poppets – allow for low-flow metering (this nozzle is not intended for high-pressure pump applications).
- ◆ Replaceable Hold-Open Rack – for use when fueling large-capacity tanks. Nozzle must be attended at all times during usage.
- ◆ Right-Angle Design – provides larger lever area for better grip and easier control; permits nozzle to fit into awkward spaces close to walls and into corners.
- ◆ Drag Lugs – protect the nozzle when dragged across rough surfaces; enhances long-life durability.
- ◆ Easy Spout Replacement – the spout is easily threaded into the body. Replacement spouts are readily available from OPW.
- ◆ NPT Female Threads at Inlet End – standard pipe threads accept all standard 1", 1-1/4", 1-1/2" and 2" male connections.

Design working pressure

- ◆ 50 psi (3.45 bar) maximum pressure

Ordering Specifications

Product #	Inlet Thread		Spout Diameter		lbs.	kg
	in.	mm	in.	mm		
190-0112	1"	25	1 1/4"	32	2.3	1.0
190-0113	1 1/4"	32	1 1/4"	32	2.3	1.0
190-0114	1 1/2"	38	1 1/2"	38	3.0	1.4
190-0115	2"	51	2"	51	5.8	2.6

OPW 190 High-Flow Manual Nozzles

For High-Flow, Bulk Fuel Oil Delivery Service

Designed to handle high flow when line pressure is not a critical consideration or otherwise absorbed.

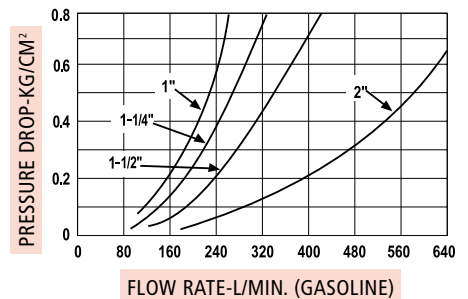
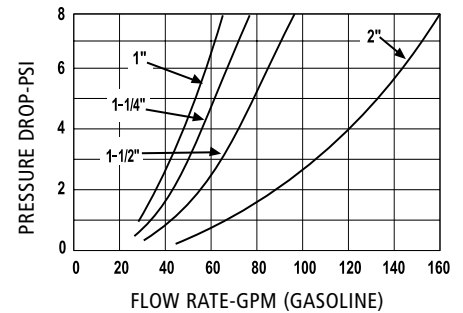

NOTE: See OPW's Website at www.opwglobal.com for product instruction sheets, troubleshooting guides, how-to-use guide and to view the Do's & Don'ts at the Gas Pump video.

Replacement Parts - OPW 190 Nozzles

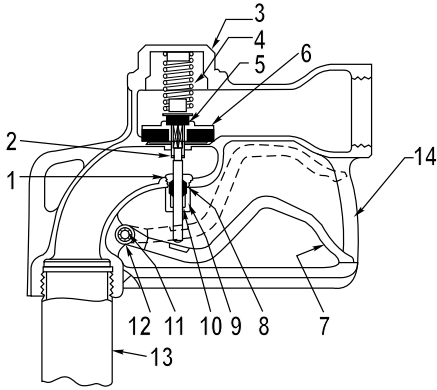

Key	Part #	Description	190-0112	190-0113	190-0114	190-0115	190-B104
1	H00195RB	Stuffing Box	•	•	•		•
1	H00250RB	Stuffing Box				•	
2	H00538RE	Stem	•	•	•		
2	H06742RE	Stem				•	
3	H09600AH	Cap	•	•	•		
3	H09601AH	Cap				•	
3	H11592AH	Cap					•
4	H00136M	Spring	•	•	•		•
4	H03666M	Spring				•	
5	190K-0001	Upper Poppet S/A	•	•	•		•
5	H01814	Upper Poppet S/A				•	
6	H01817	Lower Poppet S/A	•	•	•		•
6	H01818	Lower Poppet S/A				•	
7	H11925M	Lever	•	•	•		•
7	H06733M	Lever				•	
8	C04495M	Packing	•	•	•	•	•
9	H07012M	Packing Gland	•	•	•		•
9	H00520RB	Packing Gland				•	
10	H00113RA	Packing Nut	•	•	•		
10	H00252RA	Packing Nut				•	
10	H00113RAG	Packing Nut					•
11	H08163M	Push Nut	•	•	•	•	•
12	H08164RE	Pin	•	•	•		•
12	H08165RE	Pin				•	
13	297-9020	Spout (optional)	•	•			
13	297-9030	Spout (optional)			•		
13	297-9040	Spout (optional)				•	
13	296-0040	Spout, Brass (optional)		•			
13	296-0060	Spout, Brass (optional)			•		
13	296-0080	Spout, Brass (optional)			•		
14	C04698M	Rack	•	•	•	•	•
14	H14105M	Screw	•	•	•	•	•
Not Shown							
	296CA-4000	Dust Cap*					•
	153-0910	Strainer					•

*See page 148 for Dust Caps

Materials

- Body:** Cast aluminum
- Main Stem:** Stainless-steel
- Stem Seal:** Buna-N O-Ring
- Main Poppet Disc:** Viton®
- Spout:** OPW 297 aluminum (optional)



295SC-0141
(Spout optional, see Page 190)

Features

- ◆ Aluminum Body – lighter weight, easier to maneuver.
- ◆ Dual Poppets – easy-to-open nozzle against high inlet pressures.
- ◆ Replacement Hold-Open Rack – one-hand control of hold-open mechanism means easy setting of flow speed. Nozzle must be attended at all times during usage.
- ◆ Replaceable Composite Lever Guard – easy, low-cost replacement.
- ◆ Right-Angle Design – provides larger lever area for better grip and easier control; permits nozzle to fit into awkward spaces close to walls and into corners.
- ◆ Adjustable Dash Pot – permits adjusting the main poppet closure rate over a wide range of flows to overcome line shock with minimum afterflow.
- ◆ Built-In Swivel – eliminates twisting and kinking of the hose. This swivel is hard-coated aluminum and has full-bearing surfaces.
- ◆ Built-In Check Valve – prevents hose drainage after pump is turned off.
- ◆ Vinyl-Coated Lever – insulates fingers against cold.
- ◆ Easy Spout Replacement – the spout is easily threaded into the body. Replacement spouts are readily available from OPW.
- ◆ NPT Female Threads at Inlet End – standard pipe threads accept all 1-1/4" or 1-1/2" male connections.

Design working pressure

- ◆ 110 psi (7.58 bar) maximum pressure

Ordering Specifications

Product #	Inlet Thread		lbs.	kg
	in.	mm		
295SC-0139	1 1/4"	32	3.75	1.7
295SC-0141	1 1/2"	38	4.33	2.0

OPW 295SC High-Flow Manual Nozzles

For High-Flow, Bulk Fuel Oil Delivery Service

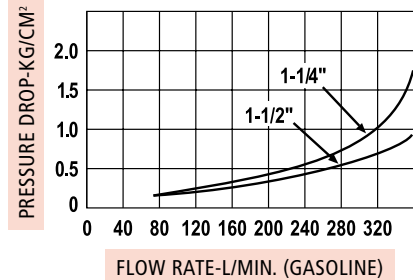
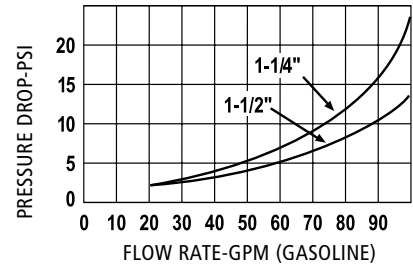

Lever Guard Replacement Kit

Part #	Description
295KLG-0200	Short Grey for 295SC-0139
295KLG-0250	Long Grey for 295SC-0141

295 Series Instruction Sheet Order Number:
H09237PA

NOTE: See OPW's Website at www.opwglobal.com for product instruction sheets, troubleshooting guides, how-to-use guide and to view the Do's & Don'ts at the Gas Pump video.

Replacement Parts - OPW 295SC High-Flow Nozzles

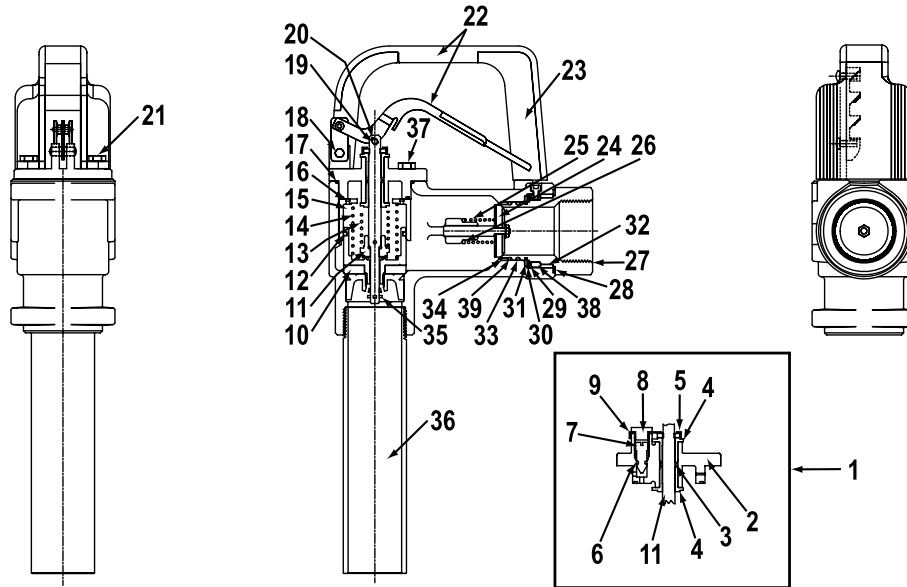

Key	Part #	Description	1 1/4" 1 1/2" NPT	1 1/2" 1 1/2" NPT
1	H09212	Cap S/A	•	
1	H09213	Cap S/A		•
2	C02115A	Cap	•	
2	C02117A	Cap		•
3	H12707M	O-Ring	•	•
4	H05063M	Bushing (2 req'd)	•	•
5	H05087M	Felt Wiper	•	•
6	H12705M	O-Ring	•	•
7	H04825M	Adjusting Screw	•	•
8	H08441RS	Screw	•	•
9	H05135M	Retainer	•	•
10	H07719	Main Poppet S/A	•	•
11	H09417	Stem & Sec. Poppet	•	
11	H09420	Stem & Sec. Poppet		•
12	H12706M	O-Ring	•	•
13	H09367M	Spring	•	•
14	H05064M	Spring	•	•
15	H05088M	Skirt	•	•
16	H05198M	Seal	•	•
17	H04828M	Seal	•	•
18	H03981RE	Pin	•	•
19	H05000M	Cotter Pin	•	•
20	H07580M	Rivet	•	•
21	H06045M	Screw (2 req'd)	•	•
22	295KLG-0200	Guard Kit	•	
22	295KLG-0250	Guard Kit		•
23	C04698M	Hold-Open Rack	•	•
23	H14105M	Screw	•	•
24	H09214	Poppet S/A	•	

Key	Part #	Description	1 1/4" 1 1/2" NPT	1 1/2" 1 1/2" NPT
24	H09215	Poppet S/A		•
25	H07593M	Spring		•
25	H07595M	Spring	•	
26	H07613M	Washer	•	•
27	295SWK-0009	Swivel Repair Kit	•	
27	295SWK-0014	Swivel Repair Kit		•
28	H08886M	Dust Seal		•
28	H01227M	Dust Seal	•	
29	H08881M	Thrust Bearing	•	
29	H08889M	Thrust Bearing		•
30	H08882M	Lock Ring	•	
30	H08890M	Lock Ring		•
31	H09365M	Retaining Ring	•	
31	H09366M	Retaining Ring		•
32	H08879M	Bearing	•	
32	H08887M	Bearing		•
33	H12319M	O-Ring	•	
33	H12320M	O-Ring		•
34	H08884M	Bearing	•	
34	H08892M	Bearing		•
35	H02477M	Cotter Pin	•	•
36	297-9020	Spout	•	
36	297-9030	Spout		•
37	H07062M	Screw (4 req'd)	•	•
38	H09712RS	Retainer	•	
38	H09713RS	Retainer		•
39	H13776M	O-Ring, Viton®		•
39	H13775M	O-Ring, Viton®	•	

Materials

- Body:** Cast aluminum
- Main Stem:** Stainless-steel
- Stem Seal:** Graphite with Teflon®
- Disc:** Viton®
- Spout:** OPW 296 brass or 297 alum. (optional)



210-0105
(Spout optional, see Page 190)

Features

- ◆ Aluminum Body – lighter weight, easier to maneuver.
- ◆ Dual Poppets – allows for low-flow metering.
- ◆ Replaceable Hold-Open Rack – for use when fueling large-capacity tanks. Nozzle must be attended at all times during usage.
- ◆ Dash Pot – non-adjustable, to minimize closing line shock.
- ◆ Right-Angle Design – provides larger lever area for better grip and easier control; permits nozzle to fit into awkward spaces close to walls and into corners.
- ◆ Drag Lugs – protect the nozzle when dragged across rough surfaces; adds to long life with rough usage.
- ◆ Easy Spout Replacement – the spout is simply threaded into the body. Replacement spouts are readily available from OPW.
- ◆ NPT Female Threads at Inlet End – standard pipe threads accept all standard 1 1/4" and 1 1/2" male connections.

Design working pressure

- ◆ 50 psi (3.45 bar) maximum pressure

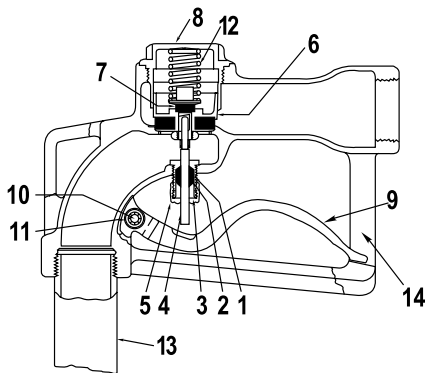

Ordering Specifications

Product #	in.	mm	lbs.	kg
210-0104	1 1/4"	32	3.95	1.8
210-0105	1 1/2"	38	4.40	2.0

NOTE: See OPW's Website at www.opwglobal.com for product instruction sheets, troubleshooting guides, how-to-use guide and to view the Do's & Don'ts at the Gas Pump video.

OPW 210 High-Flow Manual Nozzles

For High-Flow, Bulk Fuel Oil Delivery Service

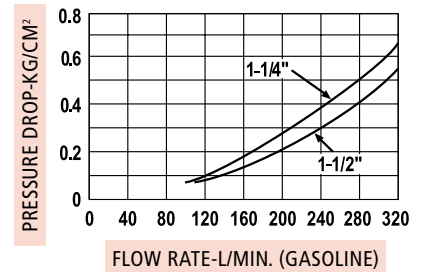
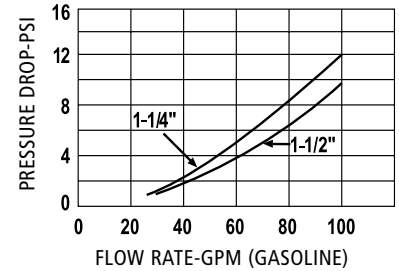

Replacement Parts

Key	Part #	Description
1	H00195RB	Stuffing Box
2	C04495M	Packing
3	H07012M	Packing Gland
4	H05719RE	Stem
5	H00113RA	Packing Nut
6	H01841	Lower Disc S/A
7	190K-0001	Upper Poppet
8	H01461AH	Cap
9	H00999M	Lever
10	H08165RE	Pin
11	H08163M	Push Nut (2 required)
12	H00136M	Spring
13	297-9020	Spout (optional) - 1 1/4" aluminum
13	297-9030	Spout (optional) - 1 1/2" aluminum
13	296-0040	Spout (optional) - 1 1/4" brass
13	296-0060	Spout (optional) - 1 1/2" brass
14	C04698M	Rack
14	H14105M	Screw

Materials

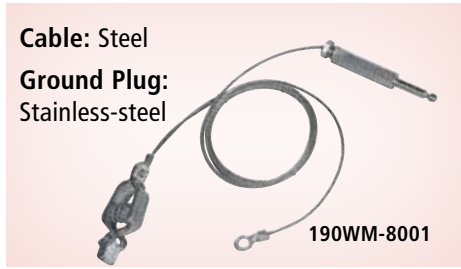

Ordering Specifications

Product #	Length		Used On
	ft.	m	
190WM-8001	6'	1.83	295SA
190WF-8002	6'	1.83	295AF

**Manual Nozzle Accessories
OPW 190 Ground Wire**

The OPW 190 ground-wire assembly is designed for use on 295 series aircraft nozzles. The OPW 190WM is designed for use with the 295SA and includes a cable, attaching eyelet, ground plug and clamp. The OPW 190WF is for use with the 295AF aircraft nozzle and includes a cable, eyelet, ground plug and dust cap.

Materials

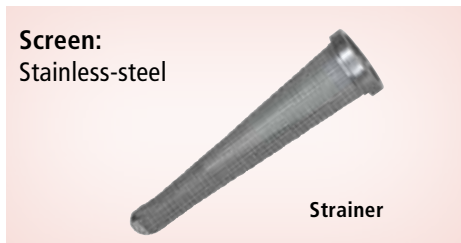

Ordering Specifications

Product #	Size		Used On
	in.	mm	
153-0910	1 1/2"	38	190G, 295SA
153J-0100	1 1/2"	38	295SAJ
190S-7063	1"	25	295SA Series w/ 1" Spout
153AF-0100	1 1/2"	38	295AF

OPW Strainers

OPW strainers prevent foreign matter from entering fuel tanks. They are held in position by a tube and have a 100-mesh screen.

Materials



Ordering Specifications

Product #	Size		Spout	Used On
	in.	mm		
296CA-4000	1 5/8"	41	296	190 1"
296CJ-0100	1 1/2"	38	696J only	295SAJ 1 1/2"
H10387	1"	26	297SA 1"	295SA
H10388	1 1/2"	38	297SA 1 1/2"	295SA

OPW 296 Protective Caps

OPW 296 Protective Caps are for use with OPW 296 and 297SA nozzle spouts. Each cap also comes with a chain and tension spring. The size ordered should be the same size as the spout O.D.

Spouts Ordering Specifications

Product #	Size		O.D.		Length		Weight		Used On	Description
	in.	mm	in.	mm	in.	mm	lbs.	kg		
297-9020	1 1/4 (NPT)	32	1 21/32	42	8	203	0.50	0.23	190-0113; 210-0104; 295SC-0139; 190-0112	Aluminum
297-9030	1 1/2 (NPT)	38	1 29/32	48	8	203	0.60	0.27	190-0114; 210-0105; 295SC-0141	Aluminum
297-9040	2 (NPT)	51	2 3/8	60	8	203	0.80	0.36	190-0115	Aluminum
297SA-9050	1 1/4 (NPSM)	32	1	25	9	229	0.60	0.27	295SA-0135, 0136, 0137 & 295SAC-0156	Aluminum
297SA-9060	1 1/2 (NPSM)	38	1 5/8	41	7	178	0.80	0.36	295SA-0138, 295SAC-0157, 295SAC-0158	Aluminum
696J-7010	1 1/2 (NPSM)	38	2 2/3	67	7 1/4	184	0.80	0.36	295SAJ-0200	Aluminum



OPW 297



OPW 297SA (9050)



OPW 297SA (9060)



OPW 696J

Materials

- Body:** Aluminum
- Main Stem:** Brass
- Main Poppet Disc:** Viton®
- Spout:** Aluminum
- Weight:** 0.5 lbs, 0.23 kg

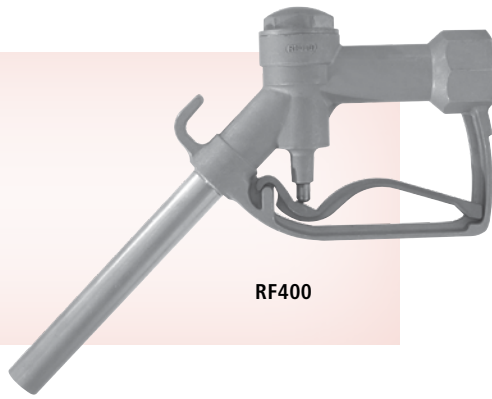

OPW RF400 Manual Utility Farm Nozzle

For General Utility Farm Usage

The OPW RF400 nozzle is designed for use in non-retail, commercial, industrial and agriculture use where an automatic nozzle is not needed.

Features

- ◆ UL-listed for use in gasoline, diesel and up to 10% ethanol blends. Specific listings available at www.opwglobal.com
- ◆ Manual Nozzle – no automatic shut off.
- ◆ Built-in hanger for quick use in field.
- ◆ **Design working pressure**
- ◆ 50 psi (3.45 bar) maximum pressure

Ordering Specifications

Product #	Description	Inlet Thread		Spout Diameter	
		in.	mm	in.	mm
RF400-75	3/4", leaded spout	3/4	19	1 3/16	34
RF400-75P	3/4", unleaded spout	3/4	19	1 3/16	30
RF400-10	1", leaded spout	1	25	1 3/16	34
RF400-10P	1", unleaded spout	1	25	1 3/16	30

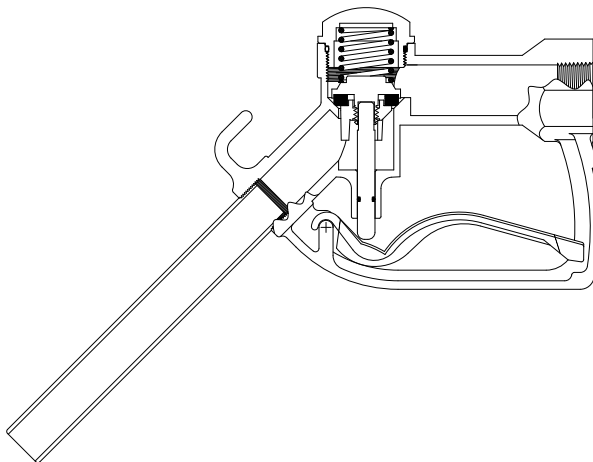
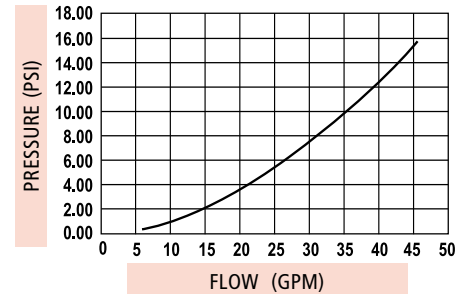
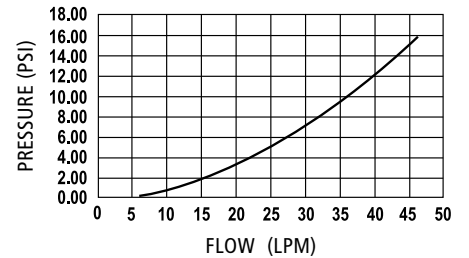

OPW 66SP High-Volume Breakaways

The 66SP is designed for installation on fuel-dispensing hoses that require a substantial volume of flow, and therefore the potential for a high-volume spill.

The 66SP utilizes shear-pin technology to ensure separation at proper pull forces, and limit unwanted valve closures that stop or limit fuel flow. Once separated, a qualified service technician can easily repair the breakaway with an OPW 66PRK Shear-Pin Replacement Kit.

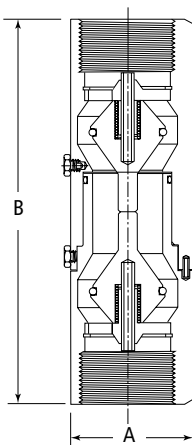
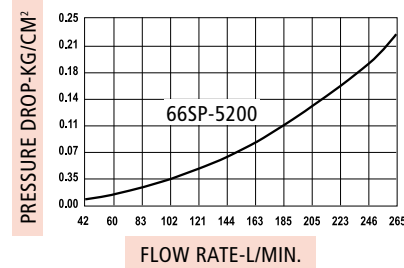
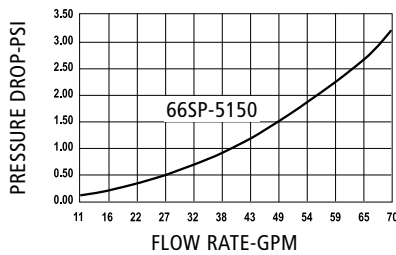

Materials

- Body:** Aluminum
- Seals:** Viton®, Buna-N and Fluorosilicone
- Spring:** Stainless-steel
- Poppet:** Aluminum
- Weight:**
66SP-5150: 1.93 lbs, .87 kg
66SP-5200: 3.80 lbs, 1.72 kg

66SP-5150



66SP-5200

Features

- ◆ Pull Force – the 66SP will separate with a maximum pull force of 600 lbs., and limits fuel spillage from either hose end.
- ◆ Easily Repaired – after separation, the 66SP can be repaired and put back in service with the OPW 66PRK Shear-Pin Replacement Kit.
- ◆ Heavy-Duty Construction – physically designed for durability in high-volume environments, including a protective, nickel-plated body.
- ◆ Low Pressure Drop – valve design ensures superior flow rate for high-volume fills.
- ◆ Special Seals – special fluorosilicone (66SP-5200 only) O-rings help protect the valve in harsh, high-volume environments.

Design working pressure

- ◆ 50 psi (3.45 bar) maximum pressure

Ordering Specifications

Product #	Inlet Thread	Weight		A		B	
		lbs.	kg	in.	mm	in.	mm
66SP-5150	1½" (NPT)	1.93	0.87	2¼"	57	7⅝"	194
66SP-5200	2" (NPT)	3.80	1.72	3½"	89	7¾"	197

Replacement Parts

Product #	Description
66PRK-5015	Shear Pin Replacement Kit for 66SP-5150
66PRK-5020	Shear Pin Replacement Kit for 66SP-5200

66SP Series Instruction Sheet Order Number: **H40128M**

Materials

Body: Aluminum

Adaptor: Zinc
Aluminum

Seals: Buna-N O-Ring,
Viton® O-Ring

Bearings: Nylon  UL-listed MH4542



36S-5080

Ordering Specifications

Product Number	Inlet Thread x Outlet Thread	lbs.	kg
36S-5080	3/4" M x 3/4" F (NPT) (19 mm x 19 mm)	0.30	0.14
36S-5090	1" M x 1" F (NPT) (25 mm x 25 mm)	0.40	0.18

OPW 36S Hose Swivel

Designed for use with fuel-oil nozzles (at inlet only), the OPW 36S provides 360° swivel action. The full-circle swivel reduces the physical strain of aligning the nozzle with the fill pipe.

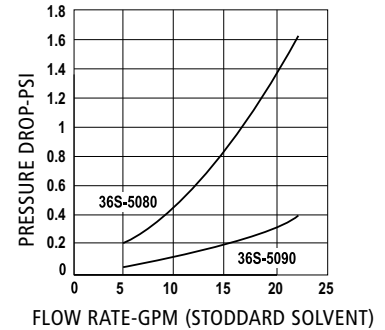

Materials

Body: Electroless nickel-plated

Bearings: Molded plastic

Seals: Buna-N O-Ring,
felt dust seal, Viton® O-Ring



25-0110

Ordering Specifications

Product #	Inlet Thread		Weight	
	in.	mm	lbs.	kg
25-0110	1 1/4" (NPT)	32	0.95	.43
25-0120	1 1/2" (NPT)	38	1.06	.48

OPW 25 Hose Swivel

Designed for use with fuel-oil nozzles (at inlet only), the OPW 25 provides 360° swivel action. The full-circle swivel reduces the physical strain of aligning the nozzle with the fill pipe.

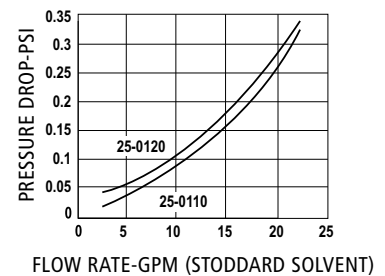
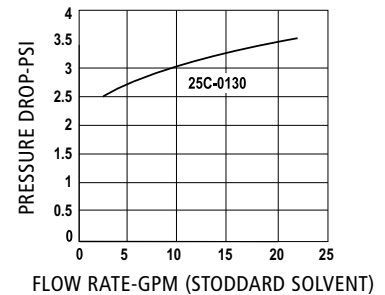

Hose Retractors



- Spring-Balance Hose Retractors 194 - 196
- Counterweight Hose Retractors (MPD) 197

Materials

Housing: Cast aluminum
Cable: Black polyester
Post: Aluminum



Nozzle Hook and Hood Kit Not Sold by OPW.

102 Spring-Balance Single-Hose Retractors

102 Spring-Balance Single-Hose Retractors keep excess hose off the ground and out of the way, prolonging hose life and reducing potential hazards. The 102 Spring-Balance Single Hose Retractor is a California Air Resources Board (CARB)-certified Stage II component for use with single and dual-hose dispensers as per Executive Order G-70-52-AM.

Features

- ◆ Easy to Use – the spring-loaded reel and stretch-resistant cable provide smooth and steady tension throughout hose extension and return.
- ◆ Easy to maintain – the removable sideplate provides full access to the mechanism for easy tension adjustment and unit maintenance. A convenient safety thumb screw is provided to lock the reel in place during tension adjustment.
- ◆ Field Adjustable for Various Hose, Nozzle, Swivel, Breakaway Combinations – no need for upgrading components if a breakaway or swivel is added to the hose assembly. Simply change the tension setting on the spring-loaded hose reel.
- ◆ Multiple Mounting Options – the 102 retractor housing is tapped on the top for bolting to overhead crossbars, and on the side for mounting to vertical posts. The 102 is available as a retractor kit (including post, retractor and mounting hardware) or as separate components. Models are also available for aboveground storage tank (AST) applications. AST models include a 44" (112cm) post with a freestanding base.

102 Spring-Balance Hose Retractor Instruction Sheet Order Number: **H15853PA**



Post Mounted

NOTE: See OPW's Website at www.opwglobal.com for product instruction sheets, troubleshooting guides, how-to-use guide and to view the Do's & Don'ts at the Gas Pump video.

Ordering Specifications

Vertical Retractor Kits (Box, Post, Bracket, Foot & Hardware)

Model Number	Mounting Method	Clamp Fits	Weight	
			lbs.	kg
6102-1039P	39" Retractor/Post Kit	(Hose Clamp Not Included)	12	5.4
6102-1078P	78" Retractor/Post Kit	(Hose Clamp Not Included)	14	6.4
6102-AST	44" AST Retractor /Post Kit	(Hose Clamp Not Included)	9	4.1

Ordering Specifications

Separate Retractor Components (Box Only)

Model Number	Description	Mounting Method	Clamp Fits				Weight	
			Hose O.D.		Hose I.D.		lbs.	kg
			in.	mm	in.	mm		
6102-1000	Standard Duty Retractor Box, 2 -10 lb retraction strength	Overhead Crossbar/Vertical Post	(Hose Clamp Not Included)				7	3.2
6102-1100	Heavy Duty Retractor Box, 12-20 lb retraction strength	Overhead Crossbar/Vertical Post					7	3.2
6102-4000		Overhead Crossbar/Vertical Post	1 ³ / ₈ "	35	1"	25	7	3.2
6102-6000		Overhead Crossbar	1 ¹ / ₃₂ "	26	⁵ / ₈ " or ³ / ₄ "	16 or 19	7	3.2
6102-8000		Overhead Crossbar	1"	25	⁵ / ₈ "	16	7	3.2

*OPW recommends using C05238M, C05261M or P100-3F/P100-44/P100-2AST for use with 102 Series retractors. Other size tubes and clamps available upon request.



Hose Clamp

Ordering Specifications

Hose Clamps

Model Number	Hose Clamp Size †
PB-1340	Coaxial Hose
PB-1344	Balanced Coaxial, Goodyear Premier
PB-1373	Standard 1" O.D. Hose (⁵ / ₈ " I.D.)
PB-1394	Standard 1 ¹ / ₈ " O.D. Hose (³ / ₄ " I.D.)
PB-1396	Standard 1 ³ / ₈ " O.D. Hose (1" I.D.)

† Other sizes available upon request

Options Replacement Parts

Model Number	Hose Clamp Size
C05238M	Post Kit, 39"(99 cm), 1 ¹ / ₈ " x 2"
C05261M	Post Kit, 78"(198 cm), 1 ¹ / ₈ " x 2"
H15212M	10 ft. Replacement Cable
P338SPOOL	Spool of Retractor Cable, 338 ft.
H15210M (P102-02)	Replacement Cable Guide
H15211M	Replacement Reel
P100-4STF	AST Replacement Base
P100-2AST	Sliding Bracket (AST)

Materials

Housing: Cast aluminum
Cable: Black polyester
Bracket: Steel

Features

- ◆ Easy to Install – each model number designates a custom-designed retractor package that mounts in the canopy of a particular manufacturer’s MPD. Packages are shipped complete with the appropriate number of retractors and all the necessary mounting hardware for a clean, professional installation.
- ◆ Easy to Use – the spring-loaded reels and stretch-resistant cables provide smooth and steady tension throughout hose extension and return.



- ◆ Easy to Maintain – the removable sideplate provides full access to the mechanism for easy tension adjustment and unit maintenance. A convenient safety thumb screw is provided on each retractor to lock the reel in place during tension adjustment.

102 Spring-Balance MPD Hose Retractor Packages

102 Spring-Balance MPD Hose Retractors keep excess hose off the ground and out of the way, prolonging hose life and preventing extra-length hoses from cluttering the island. The 102 MPD hose retractors are especially well-suited for use on Multiple-Product Dispensers (MPD) with Stage II Vapor Recovery hose/nozzle assemblies. The 102 MPD Hose Retractor is a California Air Resources Board (CARB)-certified Stage II component for use with MPDs as per Executive Order G-70-52-AM.



Ordering Specifications

Model Number	Manufacturer/Dispenser	Hoses Per Side***	Weight	
			lbs.	kg
6102-DW1037	Dresser Wayne (37" Frame)	1	40	18.2
6102-DW2037	Dresser Wayne (37" Frame)	2	50	22.7
6102-EC01	Gilbarco (Encore)	1	77	34.9
6102-EC02	Gilbarco (Encore)	2	77	34.9

*Specify dispenser model and serial number when ordering
 ***Hose clamps must be ordered separately for MPD models

NOTE: All 6102 MPDs come with two brackets and the number of hose retractors per side.

Options Replacement Parts

Model Number	Hose Clamp Size	Model Number	Hose Clamp Size
H15210M	Replacement Cable Guide	H15265M (P102-2)	Sliding Bracket
H15212M	Replacement Cable -10 ft.	C05239M	Foot (Bottom)
H15211M	Replacement Reel	D02628M	Bracket Only for 06102-DW3
D02147M	Replacement Housing		

OPW 100 Counterweight Hose Retractors

OPW 100 Counterweight Hose Retractors keep excess hose off the ground and out of the way, prolonging hose life and reducing potential hazards.

Materials

- Housing:** Impact-resistant plastic
- Cable:** Black polyester
- Post:** Aluminum (2" x 2")

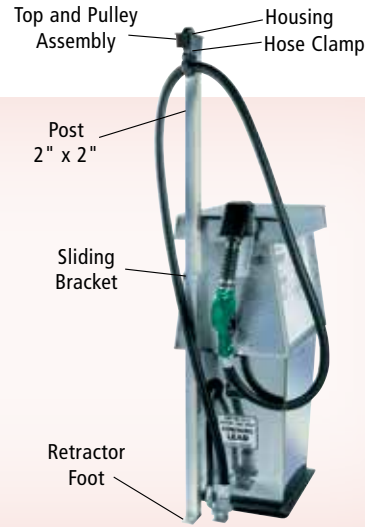

Features

- ◆ Easy to Use – counterweights are precisely matched to each hose configuration to ensure that a minimal pulling force is needed throughout hose extension.
- ◆ Easy to Maintain – the 100 has just two moving parts, ensuring a long service life with a minimum of maintenance.
- ◆ Multiple Hose Configurations – the 100 is available in a multitude of configurations to meet virtually any conventional or vapor recovery hose/nozzle configuration. Models are also available for air and water-hose applications to keep hoses clear of vehicles when not in use.

Ordering Specifications

Conventional and Vapor Recovery Applications

Model #	Hose Configuration	Hose Length		Clamp Fits		Hose I.D.		Height		Weight	
		ft.	m	Hose O.D. in.	Hose O.D. mm	in.	mm	in.	cm	lbs.	kg
6100-4000	Conventional	12-14	3.7- 4.3	1 1/8	35	1	25	79	201	33	15.0
6100-5000	Conventional	15-18	4.6 - 5.5	1 1/8	35	1	25	92	234	38	17.2
6100-6000	Conventional	12-14	3.7 - 4.3	1 1/32	26	5/8 or 3/4	16 or 19	79	201	30	13.6
6100-7000	Conventional	15-20	4.6 - 6.1	1 1/32	26	5/8 or 3/4	16 or 19	92	234	31	14.1
6100-8000	Conventional	12-14	3.7 - 4.3	1	25	5/8	16	79	201	29	13.2
6100-9000	Conventional	15-20	4.6 - 6.1	1	25	5/8	16	92	234	30	13.6
6100-AGNV	Inverted Coaxial	11-13	3.4 - 4.0	(Hose Clamp Not Included)				79	201	33	15.0
6100-AGLC	Coaxial	11-13	3.4 - 4.0	(Hose Clamp Not Included)				79	201	26	11.8
6100-AGBR	Coaxial w/ Breakaway	11-13	3.4 - 4.0	(Hose Clamp Not Included)				79	201	31	14.1

100 Series Counterweight Hose Retractor Instruction Sheet
Order Number: **H15852PA**

See page 19 for hose-clamp Ordering Specifications

Options and Replacement Parts

Part #	Description	Counterweight Length		Weight	
		in.	cm	lbs.	kg
H15262	Counterweight for 4000/AGNV Models	27	68.5	24	10.8
H15263	Counterweight for 5000 Model	31	78.7	27	12.2
H15260	Counterweight for 6000, 8000 and AGLC Models	20	50.8	17	7.7
H15261	Counterweight for 7000, 9000, AGBR Models	25	63.5	22	9.9
H15265M	Sliding Bracket, Dispenser Mount				
C05235M	Replacement Tube, 2" x 2" x 75" (191 cm)				
C05236M	Replacement Tube, 2" x 2" x 88" (224 cm)				

Part #	Description
D02671M	Replacement Housing, Plastic
H15266	Top and Pulley Assembly
H15264	12 ft. Replacement Cable
C05239M	Retractor Foot
P100-4STF	Freestanding Retractor Base
P338SPOOL	Replacement Cable Spool, 338 ft. of wire
H15210M	Cable Guide
H13588M	Retaining Ring

Aboveground Storage Tank Equipment

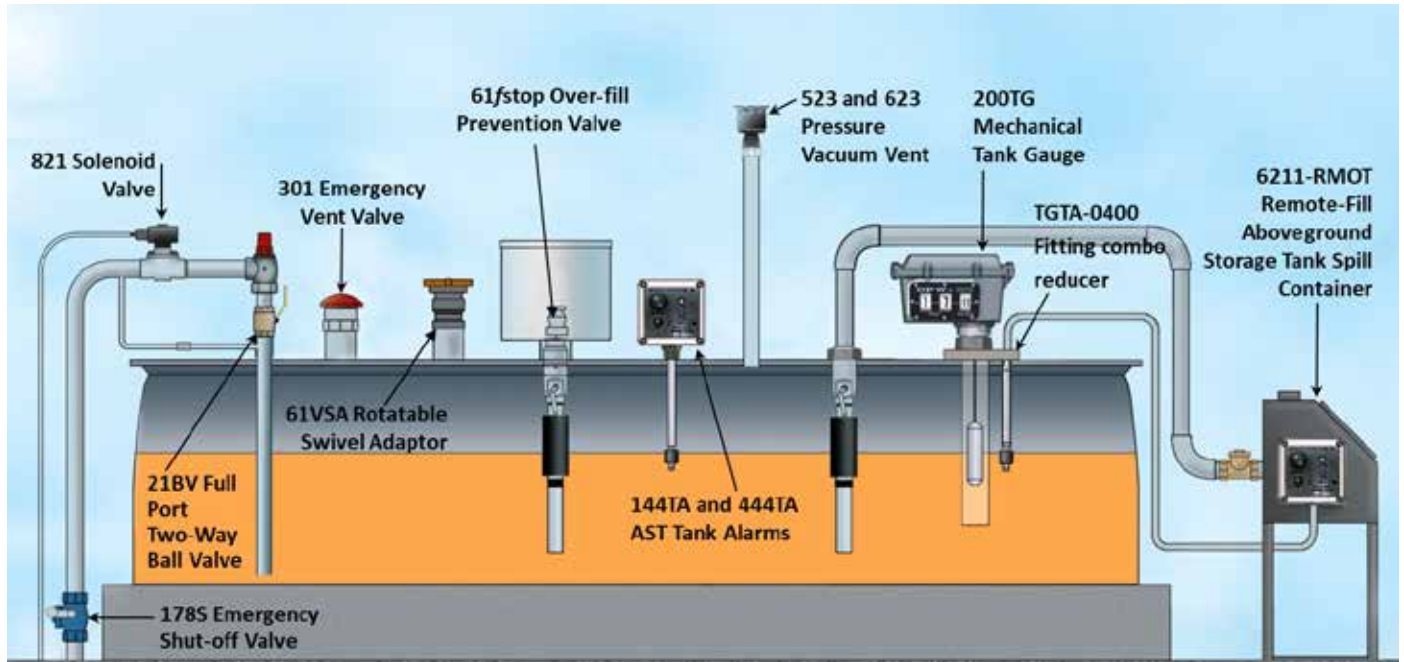

- Spill Containment 199 - 200
- Overfill-Prevention 201 - 202
- Fuel-Delivery Coupler/Accessories 203
- Mechanical Tank Gauges 204
- Tank Alarms 205
- Tank Venting 206 - 209
- Anti-Siphon Valves 210
- Solenoid Valves 211
- Emergency Shut-Off Valves 212

OPW 6221 AST Direct-Fill Aboveground Storage Tank Spill Containers

OPW Direct-Fill AST Spill Containers are designed to prevent spilled product from entering soil near the fill and vapor-return riser connections on an aboveground storage tank during normal tank-filling operation. The spill containers catch spillage to help prevent soil contamination and groundwater pollution. OPW Direct-Fill AST Spill Containers thread on the top of an aboveground tank and allow for drainage of spilled product back into the tank.

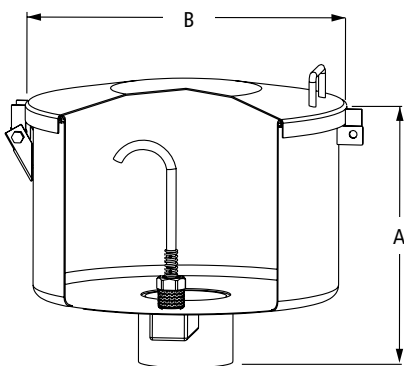

6221AST

Dimensions

Model #	Capacity		A		B	
	gal.	liter	in.	cm	in.	cm
6221	7	26.5	14½	37	17	43
	3.5	13.2	9¼	24	17	43

Features

- ◆ **Easy Installation** – 4" NPT threaded base screws directly to the tank riser pipe. No further adjustments are needed
- ◆ **Integral Drain Valve** – allows high-speed drainage of spilled product back into the tank
- ◆ **Capacity** – available in 7-gallon (26.5-liter) container capacity. Larger 7-gallon capacity spill containers provide additional clearance for 61 fSTOP Overfill-Prevention Valves (3.5 gallon-221 only)
- ◆ **Rain-Shedding Cover Design** – hooded cover design helps prevent water or snow entry by extending the lip of the cover over the body of the spill container
- ◆ **Welded-Hinge, Lockable Hatch** – the cover includes a provision for a padlock and a welded-hinge assembly for added security
- ◆ **12-Gauge Epoxy Powder-Coated Construction** – heavy-duty materials, compatible with hydrocarbons, for long service life and added security



6221AST

- ◆ **6221AST Spun-Steel Design** – spun-steel construction provides a lightweight, one-piece design for easy installation and a clean, sleek appearance on aboveground tanks.
- ◆ **All Models Are ULc-Listed** – clearly labeled to identify the listing

 Model 06221 Series only.

62121-AST Spill Containers
Instruction Sheet Order Number: 202207

Ordering Specifications:

CARB APPROVED AST EQUIPMENT

Product #	Description	Liters	lbs.	kg
6221-ASTW32	3.5 gallon, 2.0" NPT White - No Drain Valve	13.2 liter, 4.0" NPT	18	8.16
6221-ASTW34	3.5 gallon, 4.0" NPT White - No Drain Valve	13.2 liter, 4.0" NPT	19	8.61
6221-ASTW72	7 gallon, 2.0" NPT White	26.5 liter, 2.0" NPT	20	9.07
6221-ASTW74	7 gallon, 4.0" NPT White	26.5 liter, 4.0" NPT	25	11.33

Features

- ◆ **Easy Installation** – a 4" flexible boot on the back panel allows for a quick, simple connection to the remote-fill or vapor lines. Optional reducer inserts are available to accommodate 3" and 2" piping connections
- ◆ **Models to Accommodate Various Fill-Pipe Configurations** – available in 15-, 20- and 30-gallon container capacity. Smaller 15-gallon models are designed for a single-fill or vapor-return connection. Larger 20- and 30-gallon models accept both fill and vapor-return piping in a dual-port configuration. The 30-gallon model will accommodate both fill and vapor-return piping in a single-port configuration and allow the use of 3" Dry Disconnects (OPW 1611AN and 1711D) in a dual-port configuration
- ◆ **Rain-Shedding Cover Design** – hooded cover design helps prevent water or snow entry by extending the lip of the cover over the body of the spill container
- ◆ **12-Gauge Epoxy Powder-Coated Steel or 304 Stainless-Steel Containment Box** – heavy duty materials, compatible with hydrocarbons, for long service life and added security



See Product Configurator

6211-R

- ◆ **Welded-Hinge, Lockable Hatch** – cover includes a provision for a padlock and a welded-hinge assembly for added security
- ◆ **Easy Product Drainage** – lockable ball valve drain provides for quick and easy product removal
- ◆ **Height Adjustable** – adjustable legs enable the spill container to be set at a variety of heights, from 16 1/2" to 30". Each leg is independently adjustable to account for uneven ground conditions
- ◆ **Custom Sizes Available Upon Request**



Ordering Chart

6	R-				
211		15	0	B2	L
211SS		20	1	B3	LD
		30	2	B4	N
				N	ND

211 – 12-Gauge Powder-Coated Steel Construction
211SS – Stainless-Steel Construction

15 – 15-Gallon Capacity
20 – 20-Gallon Capacity
30 – 30-Gallon Capacity

0 – No entry holes
1 – 1, 4" Entry hole
2 – 2, 4" Entry holes (20 or 30 Gallon Only)

B – Booted entry fittings in holes
N – No fittings in holes
2 – 2" Fitting
3 – 3" Fitting
4 – 4" Fitting

L – Adjustable legs and No base drain valve
LD – Adjustable legs with base drain valve
N – No legs and No base drain valve
ND – No legs with base drain valve

Note: an item must be selected for each column.

Dimensions

	15 Gallon		20 Gallon		30 Gallon	
	in.	cm	in.	cm	in.	cm
A	18 1/4	46	24	61	21	53
B	7 3/8	19	7 1/2	19	10 1/2	27
C	13 3/8	35	16 1/2	42	16 1/2	42
D	16 1/2 to 30	42 to 76	16 1/2 to 30	42 to 76	16 1/2 to 30	42 to 76
E	18 1/4	46	24	61	34	86
F	9 1/8	23	12	30 1/2	9 1/2	24
G	47 to 60 1/2	119 to 154	56 1/2 to 80	144 to 203	56 1/2 to 80	144 to 203

OPW

211-RMOT Remote-Fill Aboveground Storage Tank Spill Containers

OPW Remote-Fill AST Spill Containers are designed to prevent spilled product from entering soil near the remote, horizontal-fill and vapor-return connections on an aboveground storage tank during normal tank-filling operation. The spill containers catch spillage to help prevent soil contamination and groundwater pollution. OPW Remote-Fill AST Spill Containers slip on the remote-fill and vapor-return piping connected to an aboveground tank. Compatible with methanol, ethanol, jet and AV-Gas fuels.

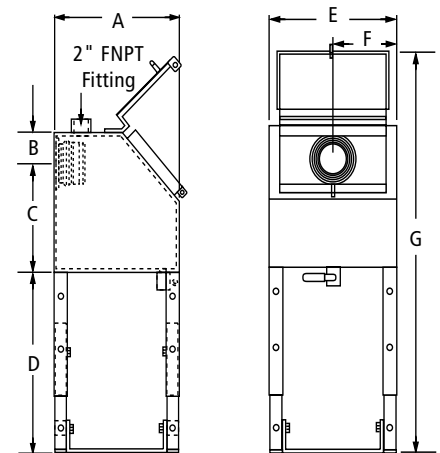

Replacement Parts

Part #	Description
201758	4 x 2 Reducer Insert
201759	4 x 3 Reducer Insert
PBOOT	Nitrile (Fuel-Resistant) Boot
H14228M	Band Clamp for PBOOT
202312	Aluminum Flange
21BV-0075	Fullport 3/4"
6211R-15-LegKit	Leg Kit - 15 Gal.
6211R-20-LegKit	Leg Kit - 20 Gal.
6211R-30-LegKit	Leg Kit - 30 Gal.
PC04427	Brass Drain Valve

211R Instruction Sheet Order Number: **H15857PA**

OPW 61fSTOP Overfill-Prevention Valves

The OPW 61fSTOP Overfill-Prevention Valve is designed to prevent overfilling of aboveground storage tanks by providing a positive shut-off during a pressurized-fill (pump-on fill) delivery. It threads into the fill opening and is an integral part of the fill tube. The 61fSTOP is fully adjustable to allow for easy installation in new or existing aboveground tanks of various heights and storage capacities.

The 61fSTOP is a single-action, complete shut-off valve. When the liquid-level rises to your specific, pre-determined tank capacity, the valve mechanism is released and automatically closes with the flow of the product. Any excess product left between the valve and the fuel-delivery coupler is drained into the tank through internal drain vents. The drain vents on the 61fSTOP act as an anti-siphon, by introducing air/vapor into the fill line, to help isolate the tank from a potential siphon due to a broken or leaking fill-pipe.

The 61fSTOP, available in either 2" or 3" full-flow models, maximizes flow rates and minimizes delivery times. The 2" 61fSTOP requires a 4" tank opening and minimum tank ullage (space from the top of the stored product to the inside top of the tank) of 8" on the 61fSTOP-1000 Cylindrical Float model and a minimum ullage of 4" on the 61fSTOP-2000 Float Arm model. The 61fSTOP-1000, with the cylindrical float, eliminates the need to position the valve to avoid tank walls or cross-bracing. The 61fSTOP-2000 with the float arm allows for increased usable storage capacity in the tank, and is well-suited for small-capacity rectangular ASTs. The 3" 61fSTOP requires a 6" tank opening and incorporates a cylindrical float requiring 8" of tank ullage space.

Materials

Valve Body, Adaptor and Collar:
Cast aluminum

Poppet: Cast aluminum, hard-coated

Cam: Stainless steel

Follower: Brass

Shaft: CRS zinc-plated

Bearing: Sintered bronze

Float: Closed-cell nitrile

Nipple: 2" - 3" schedule 40 steel pipe

Lower Nipple: 2" - 3" schedule 40 steel pipe with Duragard® coating



Features

- ◆ **A Special Crossbar Tank-Inlet Adaptor** – is provided with each Stopper to provide for tight-fills and help prohibit open-fills. Mounting hardware, upper drop tube and 14" lower drop tube provided (longer-length drop tubes can be purchased or added)
- ◆ **Completely Automatic Operation** – no pre-checks to perform, no resets, and no overrides to be broken or abused
- ◆ **Direct or Remote-Fill Compatible** – fuel-delivery couplers can be connected directly to the 61fSTOP, or steel pipe can be threaded into the top of the valve and piped to a remote location where the couplers are contained in a 211-RMOT Spill Container
- ◆ **Integral Anti-Siphon Valve** – drain vents on the 61fSTOP act as an anti-siphon, by introducing air/vapor into the fill line after the valve actuates, to help isolate the tank from a potential siphon due to a broken or leaking remote-fill-pipe
- ◆ **150-psi (10-bar) Pressure Rated* with Low Pressure Drop** – to enable quick, safe delivery of fuel into the tank
- ◆ **25 GPM (95 lpm) Minimum Flow Rate Required**
- ◆ **UL and ULc-Listed** – to satisfy third-party accreditation requirements of many jurisdictions
- ◆ **Test Kits Available** – to allow for testing shutoff functionality without removal of the valve.

*OPW does not recommend pumping pressures above 100 psi for Class 1B fuels and we make no warranties for products use in conjunction with the 61fSTOP.

NOTE: OPW recommends the use of the 61fSTOP with clean product only. Debris and other products such as contaminated waste oil may cause improper operation of the valve.

NOTE: The 61fStop can be used in gravity drop provided the minimum flow rate is maintained.

A tight shut-off is not achieved in the closed position. However with a minimum tank size of 1,000 gallons, the leak rate will provide a 30-minute warning before the tank is full.

Ordering Specifications and Dimensions

Product #	Description	A		B		C		D		E		F	
		in.	cm	in.	cm	in.	cm	in.	cm	in.	cm	in.	cm
61fSTOP-1000	2" Cyl. Float	3	7.6	10	25.4	2	5.1	9	22.4	3 ¹⁵ / ₁₆	10	n/a	n/a
61fSTOP-2000	2" Float Arm	3	7.6	10	25.4	1/2	1.3	9	22.4	1 ³ / ₂	5	6	15.2
61fSTOP-3050	3" Cyl. Float	3	7.6	10 ⁵ / ₈	27	2	5.1	8	20.3	5 ¹ / ₈	13	n/a	n/a

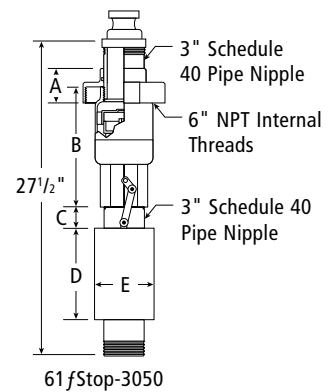
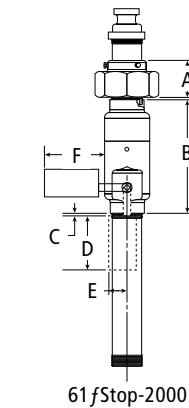
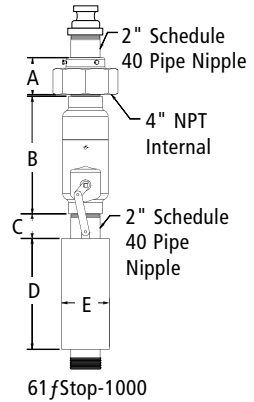

Testable Conversion Kits for 61fSTOP-1000 and -2000

Product #	Description
61TEST-2	2" fSTOP Test Kit
61TEST-3	3" fSTOP Test Kit

Replacement Parts 2"

Product #	Description
C04093M	4" Retaining Collar
C04114RS	14" Nipple

Replacement Parts 3"

Product #	Description
D02037M	6" Retaining Collar
C04474RS	14" Nipple

61fSTOP Weights

Product #	Weight	
	lbs.	kg
61fSTOP-1000	13	5.89
61fSTOP-2000	12	5.44
61fSTOP-3050	22	9.97

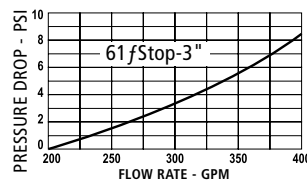
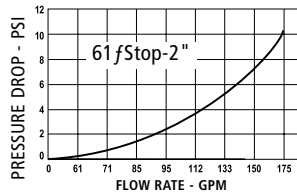

Replacement Parts 2"

Product #	Description
H12617M	Float for 1000 (4 pieces required)
61ARM-2000	Floating Arm Retrofit Kit For 2000

Replacement Parts 3"

Product #	Description
C04438M	Float (4 pieces required for 3050)

OPW 61FT Drop Tube

The OPW 61FT Drop Tube is designed to install on the bottom of the 61fSTOP AST Overfill-Prevention Valves when a lightweight, longer, lower drop tube is required. Constructed of extruded aluminum, the OPW 61FT is connected to the bottom of the 61fSTOP by a clevis and cotter-pin assembly, and allows for submerged filling of ASTs.

Ordering Specifications and Dimensions

CARB APPROVED AST EQUIPMENT

Product #	Description
61FT-0206	2" x 6' Drop Tube Kit
61FT-0312	3" x 12' Drop Tube Kit
205-0340	2- ¹³ / ₁₆ " x 1" Fill-Pipe Strainer

61FSTOP-1000 Instruction Sheet Order Number: H12676M
 61FSTOP-2000 Instruction Sheet Order Number: H13337M
 61FSTOP-3050 Instruction Sheet Order Number: H13315M
 61FT-0312, 0206 Instruction Sheet Order Number: H14428PA



Poppeted Kamvalok® Adaptors

The 1611AN Series Kamvalok® Adaptor is installed at the fill-pipe and contains an internal spring-loaded valve assembly that automatically closes to help prevent fuel spillage. The 1611AN mates with the 1711D Coupler to open the spring-loaded valve and proceed with a delivery.

Ordering Specifications

Product #	Seal	in.	mm
1611AN-0200	Remote-Fill with Buna Seal	2	51
1611AN-0300	Remote-Fill with Buna Seal	3	77
1612AN-0200	Remote-Fill with Viton® Seal	2	51
1612AN-0300	Remote-Fill with Viton® Seal	3	77
1672AN-SS20	2" Stainless-Steel Kamvalok® Adaptor	2	51
1672AN-SS30	3" Stainless-Steel Kamvalok® Adaptor	3	77

* Thread and Kamvalok® same size



Poppeted Kamvalok® Adaptors for Remote-Fill

1611AN Adaptor Instruction Sheet
Order Number: 204016

Poppeted Kamvalok® Couplers

The 1711D Series Kamvalok® Couplers are installed on the fuel-delivery transport truck hose and mate with the 1611AN Adaptors. The combination of the 1711D and 1611AN enable dry connection and dry disconnection of delivery fittings to help prevent accidental spillage of product.

Ordering Specifications

Product #	Seal	in.	mm
1711D-1080	Buna	3	77
1712D-1095	Viton®	3	77

* Thread and Kamvalok® same size



Poppeted Kamvalok® Couplers

H32116PA Coupler Instruction Sheet
Order Number: 204016

Spout Kits And Delivery Couplers And Accessories

Fuel-Delivery Couplers and Accessories are designed to connect fuel-delivery transport truck hoses or nozzles to the fill-pipe of an aboveground storage tank.

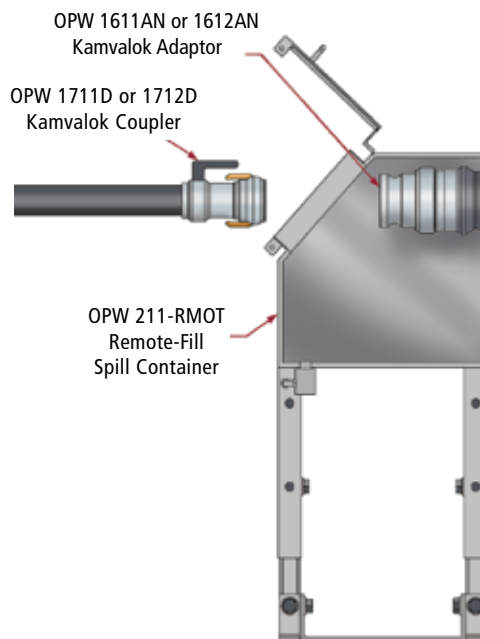

Typical AST-Filling Application

OPW 200TG AST Mechanical Tank Gauge

The OPW 200TG Tank Gauge is designed for reading liquid-levels in horizontal or vertical aboveground storage tanks. The 200TG Tank Gauge provides an accurate numerical counter readout, eliminating the need for any on-site manual gauging.

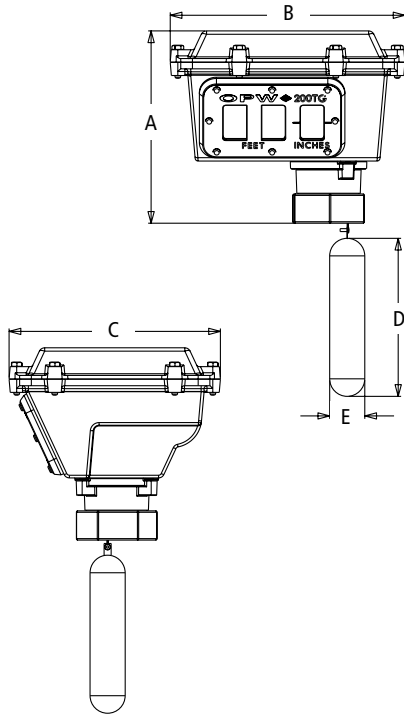

Dimensions:

	in.	cm
A	8 1/4	21
B	10 1/4	26
C	9	22.75
D	6 3/4	17.25
E	1 1/2	3.75

Replacement Parts:

Part #	Description
C05165M	Float
H15325M	Lens
H15267M	Lens Gasket
H14909M	Lid Gasket



Underwriters Laboratory Listed UL Listing MH29367. Liquid-level gauges which are intended to be used on aboveground storage tanks and monitor the level of petroleum-based flammable or combustible fluids.

Materials

- Enclosure:** Powder-coated aluminum
- Swivel Base:** Hard-coat aluminum
- Float:** 304 stainless-steel
- Lenses:** Tempered borosilicate
- Gears:** Acetal
- Gaskets & O-Rings:** Nitrile*
- All Hardware:** Stainless steel
- Accuracy:** + or - 2"



Features

- ◆ **Vapor-Tight** – allows for standard tank-pressure testing and sealing up to 25-psig (1.72 bar)
- ◆ **Angled Face** – improves visibility from ground on large-diameter tanks. May be read easily up to 30 feet away (9.14 m)
- ◆ **Swivel Adaptor Base** – allows for 360° of rotation of gauge face for easy viewing wherever needed
- ◆ **Easy Installation** – 2" NPT-threaded base reduces labor time, and comes standard with female thread. A H11421RS may be purchased for male-threaded applications
- ◆ **Corrosion-Resistant Construction** – powder-coated die-cast aluminum body assures long service life in many fluids
- ◆ **Drop Tube** – prevents float entanglement in the tank, and gives the gauge a more accurate reading when turbulence is present (Drop Tubes sold separately. They are recommended for use in tanks with high turbulence, and where other piping and structures inside the tank may cause entanglement)
- ◆ **Float Buoyancy** – designed to float in all approved fuels with a specific gravity of 0.65 and greater
- ◆ **Tank Height** – unit designed for use on any horizontal or vertical aboveground tank up to 18 feet (5.5 m) in depth. Specials available upon request
- ◆ **Numbering** – black letters on white background for ultimate contrast and better visibility. Characters stand more than 1" (25 mm) tall
- ◆ **Unit Measurement** – Can be purchased in metric units to read in meters, 1/10, 1/100, or in English units to read in feet and inches
- ◆ **Maintenance** – No annual maintenance required
- ◆ **U.S. Patent No.:** 6,523,404 - Other patents pending
- ◆ **Compatible Fuels** – see chart on page 293
- ◆ **Temperature Rating** – 120°F to -40°F (49°C to -40°C)

200TG Tank Gauge Instruction Sheet
Order Number: **H14912PA**

Ordering Specifications:

Product #	Description	lb.	kg
200TG-ENG	English Unit Tank Gauge up to 18 ft.	7.75	3.52
200TG-ENG40	English Unit Tank Gauge - 40 ft.	7.75	3.52
200TG-MET	Metric Unit Tank Gauge up to 6 m	7.75	3.52
200TGMET40	Metric Unit Tank Gauge - 10 m	7.75	3.52

(Ancillary Equipment)

Product #	Description	lb.	kg
H11421RS	2" NPT Male x Male Nipple	1.5	0.68
61T-0212	2" Dia. x 12' Long Drop Tube	4.00	1.81

Materials

- Enclosure:** Polybutylene terephthalate
- Wire Grommet:** Nylon w/Buna-N seal
- Float Switch:** Closed-cell Buna-N float & stainless-steel rod
- Pipe:** Stainless steel
- Tank Adaptor:** Aluminum hardcoat anodized

444TA



Features

- ◆ **Up to four alarm signals (444TA)** – can be used for high or low liquid-level sensing, interstitial monitoring, and/or other signals in one to four separate tanks
- ◆ **Self-Powered** – lithium battery with a 10-year shelf life for long service life.
- ◆ **Audible Alarm** – sounds a 90-decibel alarm at 4 feet away
- ◆ **Visual Notifications** – red alarm light will flash during use for notification to the user. Low-battery light indicates when battery needs to be replaced
- ◆ **Corrosion-Resistant Construction** – petroleum and environmental resistant housing and all-stainless-steel pipe fitting ensure long product life
- ◆ **Product/Alarm Identification Label** – located on top of the alarm for quick and easy identification, allowing you to correspond alarms to signals. Label has a protective covering
- ◆ **Intrinsically Safe** – complies with ANSI/UL 913 for Class 1, Division 1 & 2 for Groups C & D hazardous locations
- ◆ **Cold-Weather Resistant** – all components are safe for temperatures down to -40°F operation (and up to 120° F)
- ◆ **Long-Life Lithium Battery** – self-powered by a lithium battery which includes a 10-year shelf life to ensure peace of mind for the owner
- ◆ **Easy Installation** – requires no calibration and installs easily into a 1" tank bung. May be assembled remotely or directly on top of tank



TGTA-0400 4" Tank Bung Combo Fitting
Note: Drop Tube must be used with TGTA-0400.

444TA and 144TA Instruction Sheet
Order Number: 200655

Ordering Specifications:

Product #	Description	lb.	kg
444TA-0100*	Four Signal Tank Alarm, does not include Float Switch	4	1.8
44TA-LLFS**	36" Liquid-Level Float Switch Sub-Assembly	0	0.0
144TA-0100	Single Channel Liquid Level Tank Alarm, does not include Float Switch	4	1.8
TGTA-0400	4" Tank Bung Gauge and Alarm Combo Fitting (OPW 61T required for use)	10	4.5

**The OPW 144TA Requires the OPW 44TA-LLFS, the OPW 44TA-LLFS must be purchased as a separate item.

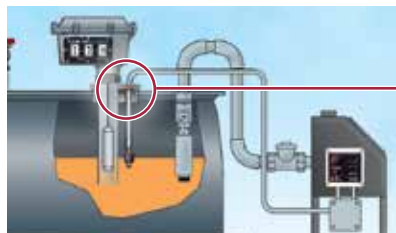

Replacement Parts:

Part #	Description
44TA-LLFS	Liquid-Level Float Switch ASSY
H15412M	Wire Fitting
H15411M	Float Switch
Items to Convert to a Low Level Alarm:	
C05295M	SST Tube
H15937M	444TA-0100 Battery Module
202891	144TA Battery Module

**OPW 444TA AST
Four-Signal Tank Alarm and
OPW 144TA AST
Liquid-Level Tank Alarm**

The OPW AST remote Four-Signal Tank Alarm is designed to sense up to four different liquid-levels or other signals using just one device.

The OPW 144TA Tank Alarm is designed for liquid-level sensing.

Alarm Technical Information:

- Hazardous Location Approval: Class I, Groups C & D
- Maximum Voltage: 7.2 Volts
- Maximum Current: 8 ma. per input (32 ma. total)
- Maximum Internal Capacitance: 23 uF
- Maximum Internal Inductance: 33 mH
- Maximum Ambient Temperature Rating: 60° C
- Maximum Surface Temperature Classification: T4 Surface Code

Wiring limitations: 1000-foot maximum between the 144TA/444TA unit and any remote switch for each channel of the alarm. This assumes that maximum capacitance for any input is 60 nanoFarads and that the maximum inductance is 0.2 milliHenry per input (UL-913 A7.3)

Note: This device is designed to work independently and should not be wired in parallel with another device, except as defined in the following instructions.

Requirements for devices wired to the 144TA/444TA:

- Attached wiring and devices must be classed Intrinsically Safe
- No voltage or current source
- Maximum capacitance: 60 nanoFarads (.06 uF) per input
- Maximum inductance: 200 microHenrys (.2 mH) per input

Float Switch Technical Information:

- Minimum liquid specific gravity: 0.45.
- Stem material: Stainless steel. Float Material: Closed-Cell Buna-N (UL Approved) for gasoline services
- Max Pressure: 150 psi @ 70° F. Thread 1/8" NPT.

444TA Dimensions:

	in.	cm
A	5 ¹ / ₃₂	12.8
B	5 ¹ / ₃₂	12.8
C	4 ³ / ₁₆	10.6

144TA Dimensions:

	in.	cm
A	5 ¹ / ₃₂	12.8
B	5 ¹ / ₃₂	12.8
C	3	7.6
D	4 ³ / ₁₆	10.6
E	1 ¹⁵ / ₁₆	4.9
F	35	88.9
G	1 ¹⁵ / ₁₆	4.9
H	1	2.5

Approvals and Listings



Conforms to ANSI / UL STD 913
Certified to CAN / CSA STD C22.2 No. 157-92
Florida EQ-610



FUELED BY EXCELLENCE

**OPW 301
Emergency Vents**

The OPW 301 Emergency Vent is designed to prevent an aboveground storage tank from becoming over-pressurized by providing high-capacity venting in the event of a fire or blockage. The 301 is a weighted, mushroom-style emergency vent. When the AST builds pressure, the weighted cast-iron lid is forced up off its seat to relieve the pressure. When pressure is relieved, the lid lowers and is automatically reset. The appropriate 301 Series vent is determined by the emergency venting capacity requirements of the AST and the type of connection at the tank’s emergency vent opening. The OPW 301 Emergency Vent is available in 4", 6" and 8" openings with female NPT, and male NPT to allow for easy installation in new or existing aboveground tanks. Various lid-pressure settings determine the initial venting of the valve.

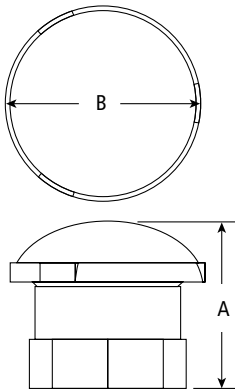

Replacement Parts

Part #	Description
201877	4" Seal
202721	6" Seal
203325	8" Seal

Materials

- Lid:** Cast iron with powder-coated finish
- Body:** Aluminum
- Shaft:** Zinc-plated steel
- O-Ring:** Buna-N

301 SCFH @ 2½ PSI
(0.17 bar)
4" - 101,000
6" - 250,000
8" - 421,000



Features

- ◆ **Automatically Resets** – weighted cast-iron cover reseats once the pressure in the tank is relieved
- ◆ **Aluminum Body and Cast-Iron Lid**
- ◆ **Epoxy Powder-Coated Cover** – prevents rusting of the cover to protect expensive finishes on ASTs
- ◆ **UL-Listed** – to satisfy third-party accreditation requirements of many jurisdictions

301 Series Instruction Sheet Order Number: **203568**

Ordering Specifications

Model #	in.	mm	Pressure Setting	Mounting Connection	A		B		Weight	
					in.	mm	in.	mm	lbs.	kg
301-4080	4	101.5	8 oz.	Female NPT	4.9	124.5	6.1	154.9	10.6	4.8
301M-4081	4	101.5	8 oz.	Male NPT	4.9	124.5	6.1	154.9	10.6	4.8
301M-4161	4	101.5	16 oz.	Male NPT	6.1	154.9	6	152.4	18.1	8.2
301-6080	6	152	8 oz.	Female NPT	5.9	149.9	8.1	205.7	20.9	9.5
301-8080	8	203	8 oz.	Female NPT	6.2	157.5	10.1	256.5	33.9	15.4

Materials

- Shear pin: Carbon graphite
- Link: Stainless steel
- Bar: Cast iron
- Lid and body: Aluminum
- Sealing surface: Teflon®-coated aluminum

202F SCFH @ 2 1/2 PSI
(0.17 bar)
8" 560,000 SCFH

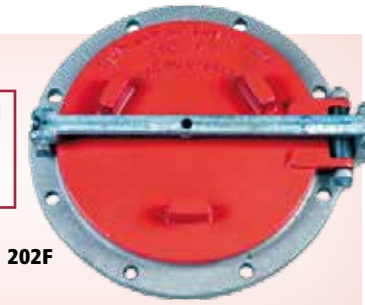

202F

Features

- ◆ **Lightweight Construction** – allows for safe, easy installation on large aboveground tanks
- ◆ **Spring-Loaded, O-Ring Sealed Cover with Teflon®-Coated Seat** – ensures smooth, vapor-tight sealing surface and reliable service life
- ◆ **Full-Bore, High-Capacity Upward Venting** – enables smaller-diameter vents, with higher venting capacity, to be used on ASTs when compared to weighted, mushroom-style vents
- ◆ **Aluminum Cover and Body with Stainless-Steel Components** – corrosion-resistant construction to protect expensive finish or epoxy coatings on ASTs
- ◆ **Alerts Tank Operators of Possible Venting Problems** – when the emergency vent is actuated, the lid remains open for inspection until manually reset. The actuation of the emergency vent indicates abnormal excessive pressure build-up in the tank due to either a blockage in the normal tank vent or in the event of a rapid expansion of vapors possibly from a fire
- ◆ **3-Point Vent Shear System** – Ensures the vent safely opens every time, even if non-OPW replacement parts are utilized. Shear Pin breaks at 2.5 psi (0.17 bar), Break Link breaks at 3.5 psi (0.24 bar), and Bar breaks at 6.5 psi (0.44 bar).
- ◆ **UL-Listed** – to satisfy third-party accreditation requirements of many jurisdictions



Ordering Specifications

Model #	in.	mm	lbs.	kg
202F-0600	8	203	5.2	2.4

Dimensions 202F

Description	in.	mm
A - Flange Hgt.	13/32	10
B - Hole Dia.	7/16	11
C - No. of Holes	8	203
D - Bolt Circle	9 1/2	241
E - Flange Dia.	10 3/8	264
F - Height	12 9/32	311
G - CL of Pivot Pt.	6 3/32	155

202F Replacement Parts

Key	Part #	Description
1	H04869RE	Break Link
2	H06475RE	Rivet
3	H04981M	Cotter Pin
4	H04928	Parts S/A
5	H04929M	Screw
6	C01288I	Bar
7	H04871M	Break Pin
8	C01289M	Gasket
9	H04873M	O-Ring
10	H06449RE	Rivet

**OPW 202F
Emergency Vents**

The OPW 202F Emergency Vent is designed to prevent an aboveground storage tank from becoming over-pressurized by providing full-bore, high-capacity venting in the event of a fire or blockage of the OPW 23, 113, 523V or 623V. The 202F is a vapor-tight, spring-loaded emergency vent. When the AST builds pressure to 2.5 psi (0.17 bar), a break-pin shears and the spring-loaded lid opens full-bore and discharges vapors upward to relieve the pressure. The lid remains open for inspection, to indicate a problem with the normal tank venting or if a fire has taken place, until manually reset. The appropriate 202F Series vent is determined by the emergency venting capacity requirements of the AST and the type of connection at the tank's emergency vent opening. The OPW 202F Emergency Vent is available in an 8" flanged connection to mount directly to a tank manway.

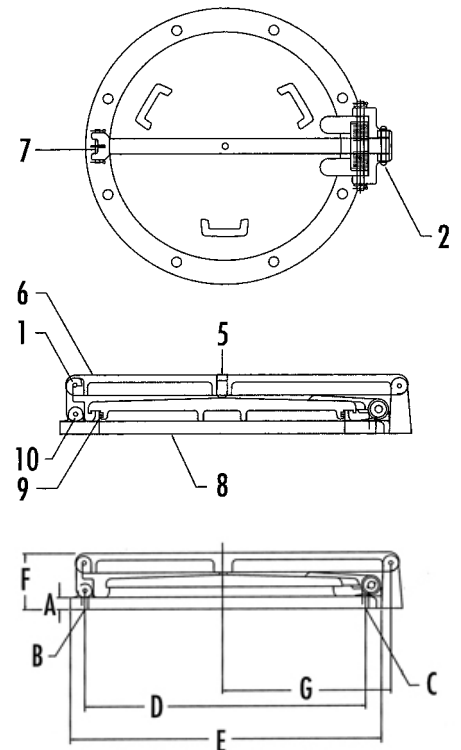

Important

FlexWorks by OPW, Inc., VAPORSAVER™ and all other OPW products must be used in compliance with all applicable federal, state, provincial and local laws, rules and regulations. Product selection must be based on physical specifications and limitations, compatibility with the environment and material to be handled. All illustrations and specifications in this literature are based on the latest production information available at the time of publication. Prices, materials and specifications are subject to change at any time, and models may be discontinued at any time, in either case, without notice or obligation. OPW warrants solely to its customer that the following products sold by OPW will be free from defects in materials and workmanship under normal use and conditions for the periods indicated.

OPW Utility Tank Vents

OPW Utility Tank Vents are installed directly on the top of aboveground storage tank or utility tank vent pipes. The vent-cap is designed to protect the tank against intrusion of water, debris or insects. The 515ML incorporates a flame-arrestor screen for jurisdictions that require these on tanks. A normally closed poppet in the valve opens at a predetermined pressure or vacuum setting to allow the tank to vent.

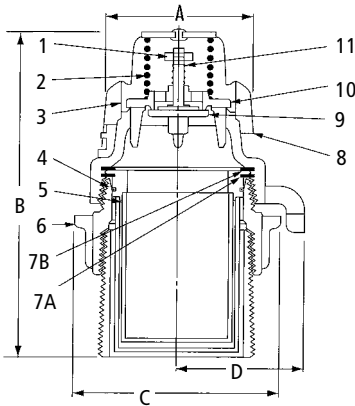

515ML

Dimensions (515ML)

	in.	mm
A	2 ⁵ / ₁₆	59
B	5 ¹ / ₄	133
C	3 ¹ / ₈	79
D	1 ¹⁵ / ₁₆	49

Materials

- Cap Body:** High-tensile aluminum alloy construction. Has straight pipe threads with Nitrile gasket for tight seal to tank.
- Dome:** Plated steel
- Screen:** 40-mesh brass



515ML

Features

- ◆ Flame-Arrestor Screen – for jurisdictions that require flame arrestors on tank vents.
- ◆ 5 PSI (0.34 bar) Pressure and 1 oz. Vacuum Settings – factory preset and tested to protect against product vapor loss and allow for rapid withdrawal of product from the tank.
- ◆ Reliable Service – precision-machined, lapped-bronze pressure and vacuum seats ensure consistent seating of the pressure/vacuum valve.
- ◆ Corrosion-Resistant Construction – zinc/aluminum alloy body and zinc-plated steel dome assure a long service life.
- ◆ Easy Installation – 515ML is available in 2" (1-1/2" NPSH) male straight threads.
- ◆ High-Maximum Flow Rate – 3500 SCFH at 7.5 psi (0.52 bar) pressure drop.

Replacement Parts

Key	Part #	Description
1	H01967M	Nut
2	H10096M	Pressure Spring
3	H07355M	Screen
4	H11432M	Seal
5	C03991M	Dome
6	H07356B	Vacuum Disc
7	H08380AH	Pressure Disc
7A	H11211M	O-Ring
7B	H03636M	Cap Gasket
8	H07353M	Vacuum Spring

Ordering Specifications

Product #	in.	mm	lbs.	kg
515ML-1030	2	51	1.80	.82

Materials

Body: Aluminum
Screen: 40-mesh brass
Set Screws: Brass



23

Features

- ◆ **Reliable Service** – vent-cap drain spouts extend outward to deter rainwater entry
- ◆ **Corrosion-Resistant Construction** – aluminum body and cap assure a long service life
- ◆ **Easy Installation** – 23 series is available in 2" and 3" slip-on models that provide for attachment to the vent line with set screws
- ◆ **Complies with NFPA 30 Requirements** – for venting gasoline vapors upward
- ◆ **High Maximum Flow Rate** – 7000 SCFH at 2 psi (0.1 bar) pressure drop
- ◆ **40-Mesh Brass Wire Screen** – helps prevent debris and insects from entering the tank vent lines

Replacement Parts

Part #	Description
H00122M	Screw
H01967M	Nut
H01969M	Screen

Ordering Specifications

Product #	Description	Weight					
		in.	mm	lbs.	kg	lbs.	kg
23-0044	Open Vent	1½	38	.25	0.11	0.25	0.11
23-0033	Open Vent	2	51	.25	0.11	0.25	0.11
23-0055	Open Vent	3	76	1.6	0.73	1.00	0.45

OPW 23 Series Open Atmospheric Vents

Open Atmospheric Vents are installed on the top of vent pipes from underground or aboveground fuel storage tanks. The vent-cap and internal wire screen are designed to protect the tank vent lines against intrusion and blockage from water, debris or insects. These vents are always open to atmosphere and allow any pressure or vacuum in the tank to vent.

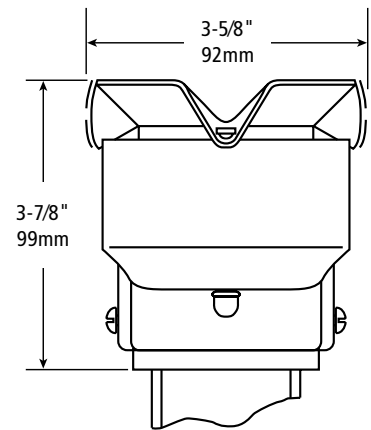

OPW 113 Series Open Atmospheric Utility Vents

OPW 113 Open Atmospheric Utility Vents are installed on the top of aboveground fuel storage tanks. The vent-cap and internal wire screen are designed to protect the tank vent lines against intrusion and blockage from water, debris or insects. These vents are always open to atmosphere and allow any pressure or vacuum into the tank to vent. The 113 vents vapors downward and is used primarily on diesel, fuel oil, waste-oil and motor-oil tanks, but can also be used on a wide variety of aboveground storage tank venting applications.

Materials

Body: Zinc/aluminum
Screen: brass
Cap: 2" - Steel 4" - cast-iron
Screen: 40-mesh stainless-steel



113

Ordering Specifications

Product #	Weight			
	in.	mm	lbs.	kg
113-0099	4	102	7.50	3.41

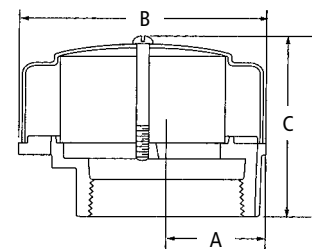

**OPW 199ASV
Anti-Siphon Valve**

The OPW 199ASV Anti-Siphon Valve is designed to help prevent siphoning of an aboveground storage tank should a leak or break occur in the fuel-supply line. The 199ASV installs on the top of an aboveground storage tank with a suction rod on the inlet and the fuel-supply line (to a remote pump) on the outlet of the valve. A poppet in the valve remains normally closed, isolating the tank from siphoning. When the remote pump is activated, it overcomes a factory-adjusted spring set to a predetermined hydrostatic head pressure and allows flow of fuel out of the AST. An internal pressure relief valve helps absorb thermal expansion in the fuel-supply line. The 199ASV is available in female NPT threads with four different factory-adjusted hydrostatic head-pressure settings.

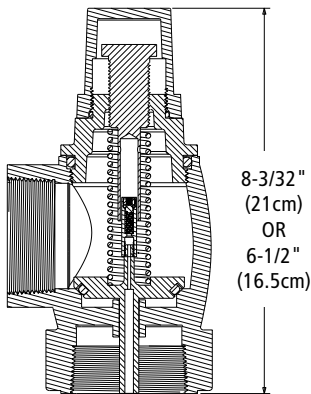

- ◆ 8^{3/32}" model for 1^{1/2}" and 2" (20.55 cm model for 3.81 cm and 5.08 cm)
- ◆ 6^{1/2}" model for 3/4" and 1" (16.51 cm model for 1.90 cm and 2.54 cm)

Materials

- Body:** Clear anodized aluminum
- Bonnet:** Powder-coated aluminum
- Cap:** Powder-coated aluminum
- Spring:** Stainless steel
- Poppet:** Hard-coated aluminum
- Screw:** Hard-coated aluminum
- Poppet Seal:** Nitrile



199ASV

Features

- ◆ **Factory-Adjusted Hydrostatic Head-Pressure Settings** – allow for quick, safe and easy installation on aboveground tanks
- ◆ **Internal Pressure Relief Valve** – helps protect piping and fittings from damage due to thermal expansion. Set to operate between 20 to 40 PSI (1.3 to 2.7 bar)
- ◆ **Aluminum Bodies** – compatible with gasoline, diesel, kerosene, ethanol, methanol, fuel oil and jet fuels
- ◆ **Temperature Rating** – -20°F - 120°F (29°C - 49°C)

Valve Rating
ft of gasoline
S.G. = 0.7

**Approximate
Cracking Pressure**

	PSI	ft. H ₂ O	in. H ₂ O	in. Hg	ft. Gas	ft. Diesel
0-5	1.88	4.33	51.96	3.85	6.2	5.35
5-10	3.68	8.48	101.76	7.53	12.12	10.47
10-15	5.6	12.92	155.04	11.47	18.51	15.95
15-20	7.4	17.07	204.84	15.16	24.4	21.07

*Note: Some suction pumps may not have enough horsepower to open valve properly.

Ordering Specifications

Product #	in.	mm	lbs.	kg	Hydrostatic Head Pressure* (Dimension A)
199ASV-1075	3/4	19	1.6	.725	0'-5'
199ASV-2075	3/4	19	1.6	.725	5'-10'
199ASV-3075	3/4	19	1.6	.725	10'-15'
199ASV-1100	1	25	1.6	.725	0'-5'
199ASV-2100	1	25	1.6	.725	5'-10'
199ASV-3100	1	25	1.6	.725	10'-15'
199ASV-1150	1 1/2	38	2.0	.907	0'-5'
199ASV-2150	1 1/2	38	2.0	.907	5'-10'
199ASV-3150	1 1/2	38	2.0	.907	10'-15'
199ASV-1200	2	51	2.0	.907	0'-5'
199ASV-2200	2	51	2.0	.907	5'-10'
199ASV-3200	2	51	2.0	.907	10'-15'

*Note: Head Pressure calculated for gasoline.

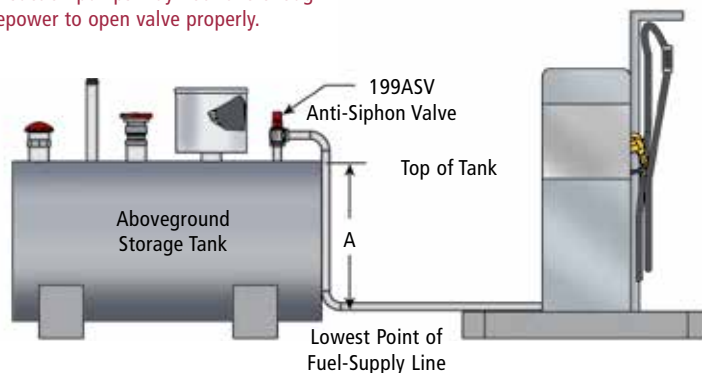

**Listings and
Certifications**



Warning: Do not disassemble.
Do not field adjust.

Materials

- Body:** Aluminum
- Diaphragm:** Viton®
- Seals & Disc:** Viton®
- Spring:** Stainless steel
- Rider Rings:** Teflon®
- Disc Holder:** Nylon
- Core Guide:** Acetal, delrin
- Core & Plugnut:** Stainless steel



OPW 821 Solenoid Valve

The OPW 821 Solenoid Valve is designed to prevent accidental siphoning of aboveground storage tanks if a leak or break occurs in the fuel-supply line. The 821 valve is a two-way, normally closed diaphragm valve that opens when energized to allow fuel to flow to the pump or dispenser. Available in female NPT threads.

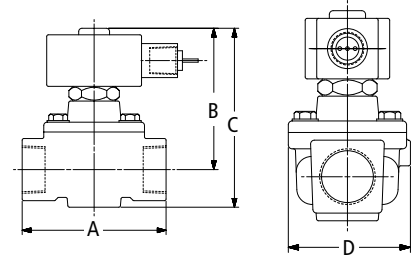

Features

- ◆ **Aluminum Body** - compatible with gasoline, diesel, kerosene, low grades ethanol/methanol, fuel oil and jet fuels
- ◆ **Strainer** - strainer with 100-mesh screen is recommended at the inlet
- ◆ **Mount** - vertical
- ◆ **Explosion-Proof Shell & Water-Tight**
- ◆ **Standard Operation** - 120/60 volts AC
- ◆ **Thermal Expansion**
- ◆ **Power Draw** - 20 Watts @ 60 Hz

82RV-2505 Series Pressure Relief Valve Instruction Sheet Order Number: 200517

Ordering Specifications

Product #	NPT Size in.	General Pur- pose	*CV Flow	Fluid Temp.	Operating Pressure Differential (PSI)		Operating Pressure Differential (BAR)		Weight		Mounting Position
					Min.	Max.	Min.	Max.	lbs.	kg	
821-0150AC	1½	AC	35	125	0	25	0	1.7	7.25	3.29	Upright & Vertical
821-0200AC	2	AC	60	125	0	25	0	1.7	7.25	3.29	Upright & Vertical

*CV Flow: GPM @ 1 psi Pressure Drop

Dimensions

Product #	A		B		C		D	
	in.	mm	in.	mm	in.	mm	in.	mm
821-0150AC	5.00	127	5.59	142	6.84	174	5.38	137
821-0200AC	6.09	155	5.94	151	7.47	190	6.31	160

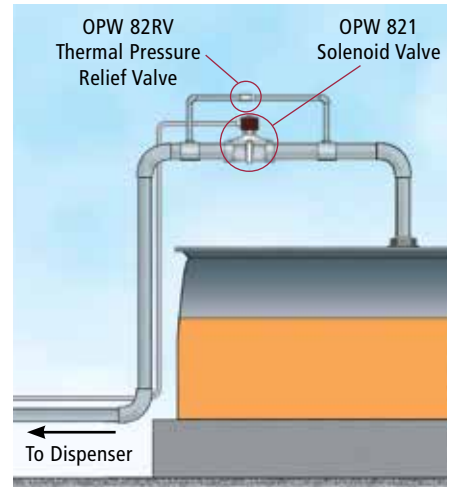

OPW 82RV - Thermal Pressure Relief Valve

Product #	NPT Size	Operating Pressure 25 psi, Stainless-Steel Construction	Weight	
	in.		lbs.	kg
82RV-2505	½		.25	.113



OPW 82RV

The 82RV is designed to give thermal pressure relief to our 821 Series Solenoid Valve line. Made of all-stainless-steel construction with a Viton® seal, it is suitable for all petroleum products. The 82RV is precision set at the factory at 25 PSI (1.7 bar), and is field adjustable from 5 to 30 psi (.34 to 2 bar).

Listings and Certifications



Materials

- Body and Cap: Ductile iron
- Packing Nut and Stem: Stainless steel
- Disc: Viton®
- Stem Seat: Viton®
- Seat Ring: Brass
- Cap and Packing Nut Seals: Viton®



(Valve Shown in Open Position)



(Valve Shown in Closed Position)

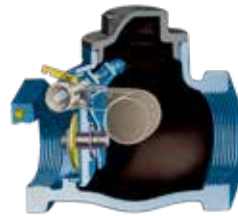

Features

- ◆ **178S Ductile-Iron Construction** – valve is manufactured from a ferrous metal to resist fracturing from high temperatures
- ◆ **Full-Bore Inside Diameter for Superior Flow Rates** – maximizes flow rates in the fuel-supply lines
- ◆ **Protected Main Poppet Disc** – main poppet seal is held out of the main flow stream and protected from damage due to dirt or debris in the fuel
- ◆ **Compensator Ring on Main Poppet Carrier** – ensures full seating of the main poppet for a tight seal
- ◆ **Viton® Main Disc and Stem Seat** – compatible with gasoline, diesel, kerosene, ethanol, methanol, MTBE, fuel oil, mogas, motor oil and various other blends of fuel
- ◆ **Rated at Normal Pressure Limit of 125 psi (8.6 bar) (cold)**
- ◆ **Non-Shock Pressure Limit of 200 psi (13.8 bar)**
- ◆ **Temperature Limit 225° F (107°C)**

Ordering Specifications

Product #	in.	mm	lbs.	kg
1785-6130	2	51	5.35	2.43

Replacement Parts

Key	Part #	Description
1	H05973M	Spring
2	H12070M	O-ring (Viton®)
3	H7635RB	Packing Nut
4	H10445M	O-ring (Viton®)
5	H01344M	Fusible Link Sub-Assy.
6	H01505RB	Pin
7	C01533RB	Stem
8	H07644M	Set Screw
9	H07642ZA	Lever
10	H03295M	Washer
11	H04035M	Disc Nut
12	H12071R	Disc (Viton®)
13	H10004A	Disc Holder
14	H11293M	Compensating Ring
15	C03144M	Carrier
16	H11547DI	Cap
17	H10003M	Retaining Ring

OPW 178S Series External AST Emergency Shut-Off Valve

The OPW 178S Series External AST Shut-Off Valve is designed to shut off product flow from an aboveground storage tank, bulk-loading rack or any place in the fuel-supply line in the event of a fire. The 178S installs in-line on fuel-supply piping. A fusible link attached to a spring-operated lever holds the poppet normally open. In the event of a fire, the fusible link melts at 160° F, allowing the spring-actuated poppet to shut off the flow of product in the fuel-supply line. The 178S is available in 2" female NPT connections.

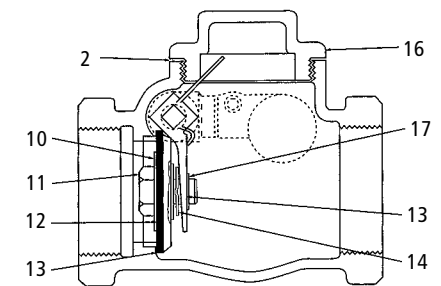
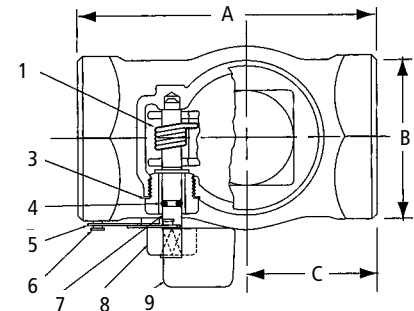

Dimensions

	in.	mm
A	5 ¹⁷ / ₃₂	140
B	3 ¹ / ₁₆	78
C	3 ¹ / ₁₆	78

For more information contact OPW Customer Service at 1-800-422-2525; International call 1-513-870-3315.





CLEANENERGY

FUELING PRODUCTS



We are dedicated to continuous innovation in the design, engineering and manufacture of high-quality components used for alternative fueling applications, such as CNG (compressed natural gas). A division of OPW, the global leader in fueling solutions since 1892, CleanEnergy Fueling Products is a name synonymous with innovation, quality, reliability and customer service. OPW CleanEnergy Fueling Products offers you a complete selection of alternative fueling products to meet your specification. Each product is designed and built to exacting standards for your fueling safety and efficiency.





CNG Fueling Nozzles (NGV1 & ISO14469)

OPW CleanEnergy Fueling Products offers an extensive line of CNG Fueling Nozzles to meet a wide variety of fueling applications. OPW CNG nozzles are used throughout the world.



NT2AP30 (Type 2 or 3)

The NEW NT2A Series Nozzle is designed to be versatile for all of your Type-2 CNG-fueling applications. The NT2A has true Class-A specified durability and will optimize your time-fill, fast-fill and fleet-fueling sites. The ergonomic design, positive locking jaws and best-in-class internal seals will make this nozzle the preferred choice of your operators.

NT2AP36 (Type 2 or 3)



CNG Type-2 Fueling System

The OPW CleanEnergy CNG 3-Way Valve and Type-2 Nozzle features the latest in industrial and commercial fueling innovations. A fueling system which bridges the gap between convenience and comfort, without sacrificing flow or reliability. Ergonomically designed to be easy to use and prevent unnecessary wear and tear during the fueling process.

1000 Series (Type 1)

OPW 1000 Series Self-Service Nozzles are designed for high-flow public and private CNG-fueling systems. Applications include quick-fill, self-service fueling of automobiles, light trucks, shuttle buses and vans.

5000 Series (Type 1)

OPW 5000 Series Nozzles are designed for extremely high-flow public and private CNG-fueling systems. Applications include quick-fill, self-service fueling of transit buses and large trucks.



6000 Series (Type 2)

OPW 6000 Series Nozzles are designed for extremely high-flow public and private CNG-fueling systems when connected to OPW CL50 series receptacles. Applications include quick-fill, self-service fueling of transit buses and large trucks.

BDN Vehicle-Defueling Nozzle

OPW has developed this tool to safely depressurize vehicles. This valve can also be used to transfer fuel from one vehicle to another in the event of a breakdown on the side of the road, or be used in areas where no refueling station is available.

OPW Listings and Certifications

Every year we introduce more safety and environmental-protection innovations to the industry than any other petroleum equipment manufacturer. Leading-edge innovations such as the new 1-2200™ single-wall replaceable spill container, 68EZR™ reconnectable breakaway, Fibrelite covers and tank sumps, decommissioning hanging hardware kits, the SiteSentinel®

Integra 100™ automated tank-gauge systems all serve to illustrate how OPW is **Leading the Way** in helping to protect the well-being of people and the environment – today, tomorrow and into the future. That’s the nature of OPW.



OPW products may hold one or more listings or certifications with the following agencies:



OPW is a member of the following associations:





Underground Products Fuel-Compatibility Matrix

Refer to individual product pages for
specific model certifications and approvals

Updated 05/2024

OPW Product Number	Description	Standard Fuels: ≤15% Ethanol Gasoline ≤5% Biodiesel*	High Ethanol Content Gasoline: 15-100% Ethanol	High Biodiesel Content 5-20% Biodiesel*	High Biodiesel Content 5-100% Biodiesel*	Av-Gas/ Jet Fuel	Kerosene/ Fuel Oil	DEF (Diesel Exhaust Fluid)	CARB EVR
CXXA Double Wall Piping V20 Vent Piping	Double Wall Primary Piping Double Wall Vent Piping	X	X	X	X	X	X	X	
DPC Series	Double Wall Pipe Couplings	X	X	X	X	X	X	X	
SPC Series	Single Wall Pipe Coupling	X	X	X	X	X	X		
SBC Series	Stainless-Steel Swivel Bolt On Coupling	X	X	X	X	X	X	X	
SMA-1515, SMA-1520, SMA-2020, SMA-3030	E-Coated Male Adaptors	X	X	X	X	X	X		
SMA-7575, SMA-1010	Swivel Male Adaptor (Brass or Zinc Plated)	X					X		
STF-1515, STF-2020, STF-2215, STF-2020	E-Coated Swivel Tees	X	X	X	X	X	X		
SFA-7575, SFA-1010	Swivel Female Adaptor (Brass or Zinc Plated)	X					X		
SEF-1515, SRE-2015, SEF-2020, SEF-3030	E-Coated Swivel Elbows	X	X	X	X	X	X		
Polyethylene and Fiberglass Sumps	Dispenser, Tank, Loop, and Transition Sumps	X	X	X	X	X	X	X	
REF & HEF Series Entry Fittings	Entry Fittings	X	X	X	X	X	X	X	
1-2100 Series / Multiports / 1-2200 Series	Spill Containers	X	X	X	X	X	X	***	X
FibreTite Multiports	Spill Containers	X	X	X	X	X	X	***	X
101BG-Series	Spill Containers	X	X	X	X	X	X	***	
1-3100 Series (Edge)	Double Wall & Single Wall Spill Container Series	X	X	X	X	X	X	***	X
60V Series	Vapor Line Shear Valve	X	X	X	X	X	X		X
10 Series	Emergency Shut Off Valve	X							
10 Plus RF	Emergency Shut Off Valve	X	X	X	X	X	X		
10 Plus Series	Emergency Shut Off Valve	X				X	X		
60V-DEF-SS	DEF Series Shear Valve							X	
61SALP & E85 Series	Fill Swivel Adaptor	X	X	X	X	X	X		X
633T-8076	Fill Adaptor	X	X	X	X	X	X		
61VSA & E85 Series	Vapor Swivel Adaptor	X	X	X	X	X	X		X
1611AVB-1625	Vapor Adaptor	X	X	X	X	X	X		
634TT-7085-EVR	Fill Cap	X	X	X	X	X	X		X
1711T-7085-EVR	Vapor Cap	X	X	X	X	X	X		X
634LPC-040	Low Profile Fill Cap	X	X	X	X	X	X		X
1711LPC-0300	Low Profile Vapor Cap	X	X	X	X	X	X		X
62M & E85 Series	Monitoring Probe Cap	X	X	X	X	X	X	X	
61SO & 71SO Series	Overfill Valve	X				X	X		
61SOM & 71SOM Series	Overfill Valve Anodized	X	X			X	X		X
71SO-B Series	High BioDiesel Overfill Valve	X		X	X	X	X		
6111 & 61TP Series	Tank Bottom Protectors	X				X	X		
61T Series	Drop Tubes	X				X	X		X
61T-SS Series	Stainless-Steel Drop Tube	X	X	X	X	X	X		
61T-DEF Series	Stainless-Steel DEF Drop Tube							X	
233 Series	Extractor Valve	X	X	X	X	X	X	X	X
FCXX Series	Stainless Flex Connectors	X	X	X	X	X	X	X	
53VML/30MV Series	Ball Floats	X	X	X	X	X	X		X
523V Series	Pressure Vacuum Vent	X	X	X	X	X	X	X	
623V Series	Pressure Vacuum Vent	X	X	X	X	X	X	X	
723V Series	EVR Pressure Vacuum Vent	X	X	X	X	X	X	X	X

* Biodiesel must meet ASTM Standard for fuel quality to maintain compatibility with products above

*** Drain-plug versions compatible with DEF if installed with Stainless-Steel Drop Tube between Nipple and Fill Adaptor

≤ Refers to less than or equal to the fuel-standard rating for percentage of content



Aboveground Products Fuel-Compatibility Matrix

Refer to individual product pages for
specific model certifications and approvals

Updated 08/2023

OPW Product Number	Description	Unleaded Fuels up to 10% Ethanol (≤E10)	Petroleum Diesel	Up to 25% Ethanol (≤E25)	Up to 85% Ethanol (≤E85)	Up to 100% Ethanol (≤E100)	Biodiesel		Av-Gas	Jet Fuel	Kerosene/Fuel Oil	CARB
							Up to 5% (≤B5)	Up to 20% (≤B20)				
11A & 11AF Series	Automatic Conventional Nozzles / Farm Nozzles		UL/ULC				UL	UL			X	
11AP & 11APF Series	Automatic Conventional Nozzles / Farm Nozzles	UL/ULC		UL/ULC								
11B Series	Pressure Sensing Automatic Conventional Nozzles		UL/ULC				UL	UL			X	
11BP & 11BP E25 & E85 Series	Pressure Sensing Automatic/ Nickel Plated Conventional Nozzles	UL/ULC		UL/ULC	UL	X						
7H & 7HB Series	Automatic High Flow Conventional Nozzles / Pressure Sensing Automatic High Flow Conventional Nozzles		UL/ULC				UL	UL			X	
12VW Series	Vacuum Assist Nozzles	UL										
14E	Automatic Nozzles	UL/ULC										X
14BP	Automatic Nozzles	UL/ULC										
14C, 14HC	Automatic Nozzles		UL/ULC				UL/ULC	UL/ULC				
66V & 66V-0492 Series	Breakaway/ Nickel Plated (Single Use)	UL/ULC	UL/ULC	UL	UL	X	UL	UL				
66REC	Breakaway (Reconnectable)	UL/ULC	UL/ULC									
68EZR Break-away	Various Reconnectable and Single Use Vac Assist Breakaways	UL/ULC	UL/ULC	UL			UL	X			X	
66SB	Swivel Breakaway	UL/ULC	UL/ULC									
241 & 241TPS-0492 Swivels	Two Plane/ Nickel Plated Hose Swivels	UL/ULC	UL/ULC	UL	UL	X	UL	UL			X	
45 Swivels	Two Plane Hose Swivels	UL/ULC	UL/ULC	UL			UL	UL			X	
36S Swivels	Straight Swivels	UL	UL				X	X			X	
25 Swivels	Bulk Straight Swivel	X	X	X			X	X	X	X	X	
311 Series	General Duty Manual Nozzles	UL	UL				X	X			X	
190/210/295SC Series	Manual Bulk Nozzles	X	X	X			X	X			X	
295SAJ	Manual Jet Fuel Nozzle								X	X	X	
295SA/SAC Series	Manual Av-Gas Nozzles	X		X					X	X	X	
1290 Series	Automatic Bulk Fueling Nozzles	X	X	X			X	X			X	
1291 Series	Automatic Bulk Fueling Nozzles	ULC	ULC				ULC				ULC	

UL - UL listed X - Compatible ULC - UL Canada



Aboveground Storage Tank Equipment Fuel-Compatibility Matrix

Refer to individual product pages for specific model certifications and approvals

Updated 08/2023

OPW Product Number	Description	Unleaded Fuels up to 10% Ethanol (≤E10)	Up to 25% Ethanol (≤E25)	Up to 85% Ethanol (≤E85)	Petroleum Diesel	Biodiesel		Av-Gas	Jet Fuel	Kerosene/Fuel Oil	CARB
						Up to 5% (≤B5)	Up to 20% (≤B20)				
523V Series	Pressure Vacuum Vent	UL	X	X	UL	X	X	X	X	X	
623V Series	Pressure Vacuum Vent	UL	X	X	UL	X	X	X	X	X	
301 & 201 Series	Emergency Vents	UL/ULC	X	X	UL/ULC	X	X	X	X	X	
200TG Series	AST Mechanical Gauge	UL	X	X	UL	X	X	X	X	X	
444TA Series	Tank Alarms	ETL	X	X	ETL	X	X	X	X	X	
821 Series	Solenoid Valves	UL	X		UL	X		X	X	X	
21BV SS	Full Port Stainless-Steel Ball Valves	UL/ULC	X	X	UL/ULC	X		X		X	
61f STOP	AST Overfill Valve	UL/ULC	X		UL/ULC	X	X			X	

UL - UL listed X - Compatible ULC - UL Canada

OPW Approvals/Listings

FlexWorks Third-Party Approvals - FlexWorks Products

Product	Certifying Agency:	Specification/Standard:
AXP, DS, DP, DBS, DSE, DSW, FCS, FTS, MBS, PSL, REF, S, SBK, SMF, TFA, TSD, TSE, TSS, TSM, PTS, DSL series and HEF series	Underwriters Laboratories Inc. UL Listed per: File MH60659	UL Listed per: UL 2447 & ULC 664, Containment Sumps, Fittings, and Accessories for Fuels
Primary/Secondary Pipe and Couplings C075A, C10A, C15A, C20A, C30A Series and V20	Underwriters Laboratories Inc. File: MH16678	UL Listed per: UL 971 - Non-metallic Underground Piping for Flammable and Combustible Liquids (Motor Vehicles, Aviation, Marine Fuels)
V20 Vent Piping	Underwriters Laboratories Inc. File: MH16678	UL 971 Listed, Integral Primary/Secondary, Normal Vent & Vapor Piping, Gasoline, Aviation & Marina Fuels
Primary/Secondary Pipe and Couplings C075A, C10A, C15A, C20A, and C30A Series	ERA Technology Ltd EN14125	
Sealant Polyurethane Adhesive/Sealant Product #: FlexWorks SL-1100 and BOSTIK-1100FS	State of California Registered Professional Engineer Approval (RHL Design Group) OPW Test Report #3505 Dated 11/16/99 May National Associates, Inc. Project Report #PU051502 06/26/02 May National Associates, Inc. Project Report	CCR Title 23 Division 3, Chapter 16, Section 2631 (d) AB2481 requires secondary containment for all underground piping in UST system

FlexWorks Third-Party Approvals - ERA-Certified Products

Product No.	Description	Certification
FlexWorks	Primary/Secondary Containment Pipe & Couplings	BC63/0433/98.003

FlexWorks Florida EQ Certifications

Product No.	Description	Certification
C075, C075A, C10, C10A, C15, C15A, C20, C20A, C30, C30A	Primary Pipe	Florida EQ-649 & EQ-772
Loop System	Piping/ Piping With Enclosed Secondary Containment Equipped with Sump Liner, Dispenser Liner, and Interstitial Release Detection (Flexible Piping)	Florida EQ-709
TSD, TSM and TSS Series DSF Series FTS Series FCS Series DSE Series	Piping/ Piping With Enclosed Secondary Containment Equipped with Sump Liner, Dispenser Liner, and Interstitial Release Detection (Flexible Piping)	Florida EQ-318 Florida EQ-368 Florida EQ-912 Florida EQ-913 Florida EQ-966

OPW Patents - FlexWorks Piping Systems, Sumps, Fittings

United States Patents

5,813,797	6,099,202	6,729,797	8,020,576	8,667,687
5,819,975	6,116,817	7,073,976	8,066,024	
5,950,860	6,371,154	7,104,727	8,393,647	
6,039,201	6,565,127	7,578,308	8,622,097	

Ireland, Scandinavia, Luxembourg Patents

213-530

Poland Patents

11,401,010-00-203373-USDCURRO1-59

Taiwan Patents

8,920,312

Europe Patents

3356-54EP

Brazil Patents

PI9908225-0

China Patents

05-100023269

Canada Patents

2,322,216	2,492,346	2,782,925		
-----------	-----------	-----------	--	--

Mexico (Patent Application No.)

002,952	209,733	221,155	984,583	993,305
194,949	218,307	984,582	993,304	999,158

Spain (Patent Application No.)

97,909,839.9

Argentina (Patent Application No.)

AR008317B1	AR008316B1	AR008312B1		
------------	------------	------------	--	--

California Air Resources Board, EVR, State of Missouri and Mexico Approvals

Product #	Description	Approval #	EVR Executive Order #	MOPETP #	Mexico Approvals
1611AV-1620	Vapor Recovery Adaptor	MO. No. 99-03 / 98-06		APCP-0002-001-99	
1-2100	Spill Container	CARB No. 93-26	VR-102	APCP-0002-001-99	
1-2100 (EVR) (ISC)	Spill Container (with drain valve)	MO. No. 99-03	VR-102	APCP-0002-001-99	
1C-2100 (EVR)	Spill Container	CARB No. 93-26	VR-102	APCP-0002-001-99	
1C-2200	Spill Container		VR-102		
1-2115 (EVR)	Spill Container	CARB No. 93-26	VR-102	APCP-0002-001-99	
1C-2115 (EVR)	Spill Container	CARB No. 93-26	VR-102	APCP-0002-001-99	
1DK-2100	Replacement Drain Valve Kit	Approval CARB No. 95-7	VR 102		
1DP-2100	Replacement Drain Plug Kit		VR-102		
1-3100	Spill Container	MO. No. 06-01A	VR-102		
101BG(S)-2100	Spill Container	CARB No. 93-26			
101BG(S)-2115	Spill Container	CARB No. 93-26			
30MV	Ball Float Vent Valve	CARB No. 95-33			
P500 Series	Spill Container		VR-102		
P700 Series	Spill Container		VR-102		
53FC	Float Vent Valve	MO. No. 99-03		APCP-0002-001-99	
53VML	Ball Float Vent Valve	CARB No. 92-4		APCP-0002-001-99	
60VP	Vapor Shear Valve	CARB No. 94-27			
60VSP	Vapor Shear Valve	CARB No. 97-15			
60VSPC	Vapor Shear Valve	CARB No. 97-15			
61SA	Swivel Adaptor	CARB No. 95-1		APCP-0002-001-99	SEGEMDGPCCAT-MTSRV-DOVER/001/2004
61SA Tool	Installation Tool		VR-102		
61SO	Overfill Valve	CARB No. 92-5/93-2/97-04/95-17			
61SOM	Overfill Valve	CARB No. 92-5			
61SOP	Overfill Valve	CARB No. 92-8			
61VSA (EVR)	Vapor Swivel Adaptor	CARB No. 00-11	VR-102	APCP-0002-001-99	SEGEMDGPCCAT-MTSRV-DOVER/001/2004
61JSK (EVR)	Jack Screw Kit for 61SO		VR-102	APCP-0002-001-99	
61SALP-EVR	Fill Swivel Adaptor		VR-102	APCP-0002-001-99	
FSA-400	Face Adaptor		VR-102	APCP-0002-001-99	
61AS	Side-Seal Adaptor	CARB No. G70-97A			
61T	Drop Tube	CARB No. G70-97A	VR-101 & VR-102	APCP-0002-001-99	
61TCP	Coaxial Drop Tube	CARB No. 93-1			
62	Side-Seal Cap	CARB No. G70-97A			
62M	Monitoring Cap		VR 102	APCP-0002-001-99	
62TT	Side-Seal Cap	CARB No. G70-97A			
116	Cap	CARB No. G70-97A			
7150-400C/410C/420C (T)	Vapor-Tight Overfill Valve		VR-102	APCP-0002-001-99	
233V	Extractor	CARB No. G70-97A		APCP-0002-001-99	
233VM	Extractor	CARB No. G70-97A		APCP-0002-001-99	
233SD	Extractor	CARB No. G70-97A			
233VTS	Extractor/Assembly	CARB No. G70-97A			
311	Multi-Port Spill Container	CARB No. 93-25			
511	Multi-Port Spill Container	CARB No. 92-12			
500L	Replaceable Spill Bucket		VR-102	APCP-0002-001-99	
6500 Series (EVR)	Multi-Port		VR-102	APCP-0002-001-99	
523	Pressure/Vacuum Vent	CARB No. 94-22/92-28/94-11			
523V	Pressure/Vacuum Vent	CARB No. 98-1		APCP-0002-001-99	
633LC	Locking Clamp	CARB No. 97-14		APCP-0002-001-99	
633T	Top-Seal Adaptor	CARB No. G70-97A		APCP-0002-001-99	
633TCP	Top-Seal Adaptor	CARB No. G70-97A			
634TT (EVR)	Top-Seal Cap	CARB No. G70-97A	VR-101 & VR-102	APCP-0002-001-99	
700L	Testable/Replaceable Spill Bucket		VR-102		
1711T (EVR)	Vapor Recovery Cap	CARB No. G70-97A	VR-101 & VR-102	APCP-0002-001-99	
1711TK	Cap	CARB No. G70-97A			
6111-1400 (EVR)	Tank Bottom Protector	CARB No. 98-21	VR-102	APCP-0002-001-99	
211	Spill Container	CARB No. AGT-94-01			
1711LPC	Low Profile Vapor Cap		VR-101, VR-102, VR-103, VR-104, & VR-105	APCP-0002-001-99	
634LPC	Low Profile Fill Cap		VR-101, VR-102, VR-103, VR-104, & VR-105	APCP-0002-001-99	

California Air Resources Board, EVR, State of Missouri and Mexico Approvals

Product #	Description	Approval #	EVR Executive Order #	MOPETP #	Mexico Approvals
723V	Vacuum Vent		VR-102		
71JSK	Jack Screw Kit		VR-102		

UL-Listed Products - Underground Products

OPW Approvals/Listings

Product	Description	File #
10 Series	Emergency Shut-Off Valves	MH6535
523V, 623V and 723V	Pressure/Vacuum Vents, tested per UL 2583	MH19391
61AS, 61SALP, 62M, 62MAB, 62MBB, 633T, 634LPC, 634TE, 634TT, 1611AV, 1711T, 1711LPC, 61VSA Series. EGVV per UL 2583	Caps & Adaptors	MH19391
60V, 60VP, 60VSP, & 60VSPC	Vapor Shear Valves	MH6535
6150 & 7150 Series	Overfill Valve	MH19391

ULc-Listed Products - Underground Products

Product	Description	File #
10 Series	Emergency Shut-Off Valves	MH27238
6150 & 7150	Overfill Valve	MH21147
7150	Vapor-Tight Overfill Valve	MH21147
70S	Vertical Check Valve	MH27238
1, 15C & 101BG	Spill Containers	MH27236
Flex Connectors	Stainless-Steel Flexible Connectors	MH48310
Fibrelite Multiport	Spill Containment Manholes	MH27236

ERA-Certified Products - Underground Products

Product	Description	File #
FlexWorks	Primary/Secondary Containment Pipe & Couplings	BC63/0681/97/003; BC63/0681/97/004

ATEX-Certified/Compliant - OPW Underground Products

Product	Description	Certificate #
523 P/V Vent	Type 523 P/V vent - End-of-line Deflagration Flame Arresters, 523 METAL UK, 523 METAL UKDI	Sira 05ATEX9050X
623 V Vent	End-of-Line Deflagration Flame Arresters 623-V 2203, 0623-V 3203	Sira 05ATEX9049X
66VL Breakaway Valves	66VL-01AT, 66VL-02AT	Sira 06ATEX9326U
Model 10 Series Shear Valves	Emergency Shut-Off Valves	Sira 06ATEX9341U
7150, 6150	Overfill Valve	Sira 08ATEX9047, Sira 08ATEX9048
60VP-101L	Vapor Recovery Shear Valve	Sira 17ATEX9143U

Florida EQ Certifications

Product #	Description	Certification
111/211/311/511	Multi-Port Spill Containers	EQ-145
1, 15C, 101BG, 111, 211 Series	Spill Containers	EQ-224
1C-3101D, 1C3101P	EDGE 1" Series Single Spill Container	EQ-718
1C-3100 Series	EDGE" Double Wall Spill Container	EQ-708
6150, 61TNG, 53V, 30MV Series	Overfill Valves & Ball Floats	EQ-223
7150 Series	Overfill Prevention Valve	EQ-697
7150 Testable Series	Overfill Prevention Valve	EQ-815
1-3100 15 Gallon Series	Spill Containment	EQ-794
1-3700 Retrofit Series	Spill Containment Replacement	EQ-795
332 AST Series	Direct-Fill Spill Container	EQ-814
1-2200 Series	Spill Container	EQ-829
Fibrelite Multiport	Spill Containment Manholes	EQ-859

North Carolina

Product #	Description	Certification
IC-3100	Double Wall Spill Container	

Wisconsin Department of Commerce

Product #	Description	Certification
FC XX-XXXX	OPW Flex Connectors	

Arizona Department of Weights and Measures

Product #	Description	Certification
6150-EVR	Overfill Protection in Vaulted Systems	VR Alert No. 12

OPW Patents - Underground Products

Emergency Shut-Off Valves (10 Plus Series)

Patent #	Country
7,578,308	USA
8,020,576	USA
8,066,024	USA
9,845,896	USA
P10,703,905-0	Brazil
2,605,139	Canada
017,913	Eurasian Patent Convention
200,710,166,890.3	China
1,916,221	Europe, Spain, France, Great Britain, Italy, Poland
2,314,541	Europe, Germany, Spain, France, Great Britain, Italy, Poland
300,952	India
5,128,901	Japan
1497148	Korea
277,128	Mexico
2,314,541	Poland
017,913	Russia
1,337,236	Taiwan

Spill Containers

Patent #	Country
8,622,097	USA
2,717,743	Canada

Coax Couplings

Patent #	Country
6,565,127	USA

Loop System

Patent #	Country
7,073,976	USA

Drop Tube (7150)

Patent #	Country
7,069,965, 7,243,675, 6,913,047, 7,128,102, 7,213,610, 7,437,815, 7,243,675	USA
2,503,927, 2,503,671, 2,503,923, 2,503,667, 2,503,924, 2,503,676	Canada
1,344,920, 1,333,920, 1,347,918, 1,331,115	Taiwan
290,614, 304,329, 278,650, 297,969, and 294,422	India
4,813,085 and 4,871,525	Japan
10-1,050,556 and 10-1,057,906	Korea

DPC with Test Port

Patent #	Country
7,104,727	USA

SBC Coupling

Patent #	Country
8,393,647	USA

REF Fitting

Patent #	Country
8,667,687	USA
2,782,925	Canada

Electrotite Junction Box

Patent #	Country
10,218,163	USA
2,965,929	Canada
382,369	Mexico

Matador Backfill Protector

Patent #	Country
10,294,627	USA

Testable Overfill Valve

Patent #	Country
9,463,971	USA
11,061,418	USA
2,801,784	Canada
2,631,211	Europe, Germany, France, UK
3,124,431	Europe, Germany, France, UK
13,155,871.4	Europe
16,185,737.0	Europe

CARB EVR-Certified Products - Aboveground Storage Tank Equipment

Product	Description	EO Number
61VSA-1020-EVR	Rotatable Swivel Adaptor	VR 401
1711T-7085-EVR & 1711LPC-0300	Vapor Recovery Caps	VR 401
66CLP-5100	Balance, Reconnectable Breakaway	VR 204, VR-203

CARB (Pre-EVR) Certified Products

Product	Description	CARB Certification	CA Fire Marshal
12VW	Vacuum-Assist Nozzle	G-70-153, G-70-150, G-70-199	GVRC: 005:008:059
66CAS	Dry Reconnect Inverted Breakaway	96-18	GVRC: 005:008:056
66ISU	Vacuum-Assist Breakaway	94-9	GVRC: 005:031:009
66ISB	Swivel/Breakaways	95-35	GVRC: 005:031:016
66CL/CSU/CLP	Coaxial Breakaway	91-14	GVRC: 005:008:047
Vacurite® 00-40005C	Centralized Vacuum-Assist Vapor Recovery System	G-70-164-AA, G-70-175	GVRC: 004:001:001
Max Vacurite® AST 00-40001C	Centralized Vacuum-Assist Vapor Recovery System	G-70-164-AA, G-70-175-AST	GVRC: 004:001:001
VacuChek™	Air to Liquid Test Equipment	CARB Approved Alternative to TP-201.5	N/A
VaporSaver™	Tank Pressure Management System	G-70-204A	GVRC: 005:008:062
523V	Pressure/Vacuum Vent	CARB No. 98-1	N/A

OPW Patents - Aboveground Products

Nozzles

Patent #	Country
5,645,115	USA
5,454,602	USA
5,813,443	USA
5,620,030	USA
5,4353,57	USA
5,577,538	USA
5,832,970	USA
6,851,628	USA
6,951,229	USA
8,371,341	USA
8,376,000	USA
8,616,252	USA
8,528,609	USA
8,631,837	USA
8,636,027	USA
7,134,580	USA
6,024,140	USA
9,126,820	USA
9,260,286	USA
9,527,720	USA
10,023,458	USA
10,081,532	USA
10,273,137	USA
10,669,149	USA
11,673,793	USA
11,554,949	USA
11,235,966	USA
D728,736	USA
D738,461	USA
2011316968	Australia
348967	Australia
349307	Australia
2767249	Canada
2897695	Canada
ZL201080052182.7	China
ZL201180056513.9	China
ZL201180058887.4	China
ZL201330216105.7	China
ZL201480008253.1	China
XL201510407818.X	China
9178054.4	EPC
002145748-0001 and 002145748-00002	European Union
254172	India
254173	India
IN395772	India
326551	Mexico
369241	Mexico
417587	New Zealand
417970	New Zealand
598980	New Zealand
609846	New Zealand
91392	Russia
2013119834	Russia
2013/02827	South Africa
93130770	Taiwan
1636000	Taiwan

Breakaways

Patent #	Country
5,695,221	USA
5,564,471	USA
5,570,719	USA
8,931,499	USA
5,529,085	USA
9,528,648	USA
10,336,604	USA
11,603,954	USA
17/005,708	USA
2,904,305	Canada
17/005,708	Mexico

Island Forms

Patent #	Country
6,099,202, 6,375,384B1	USA
12,274,17C	China
2,322,216	Canada
221,155	Mexico

Storage Tank Emergency Vent Valve (AST)

Patent #	Country
5,141,020	USA

Storage Tank Shut-Off Valve (61fSTOP) AST

Patent #	Country
5,472,012	USA
5,850,849	USA

Tank Gauge (AST)

Patent #	Country
6,523,404, 7,174,784	USA
P10501119-1	Brazil
2,492,346	Canada
94,100,860	Taiwan
05-10,002,326.9	China
22/che/2005	India
2005-7183	Japan
4005/2005	Korea

UL-Listed Products - Aboveground Products

Product	Description	File #
11A Series	Automatic Nozzle	MH1942
11B Series	Pressure-Sensing Automatic Nozzle	MH1942
7H Series	Automatic Nozzle	MH1942
7HB Series	Pressure-Sensing Automatic Nozzle	MH1942
11AF	Farm Nozzle	MH1942
11BP E85	Pressure-Sensing Automatic Nozzle for E85	MH1942
12VW	Vacuum-Assist Nozzle	MH1942
21BV Series	Ball Valves	MH65660
241TPS	Two-Plane Swivel	MH4542
241TPS-0492	Two-Plane Swivel for E85	MH4542
36S	Hose Swivel	MH4542
45	Hose Swivel	MH4542
MFVA	Vacuum-Assist Vapor Recovery Swivel	MH4542
199ASV	Anti-Siphon Valve	MH8488
44	Flow Limiters	MH8488
523V & 623V	Pressure/Vacuum Vents	MH19391
623V XXXX	Pressure Vacuum Vent	MH19391
821 Series	Solenoid Valve	E12264
66SB	Swivel Breakaway	MH18037
66ISB	Vacuum-Assist Vapor Recovery Breakaway	MH18037
66REC	3/4" Reconnectable Breakaway	MH18037
66V	Breakaway	MH18037
66V-0492	Breakaway for E85	MH18037
66CAS	Dry Reconnect Inverted Breakaway	MH18037
66EZR	Dry Reconnect Inverted Breakaway	MH18037
66CLP	Coaxial Breakaways	MH18037
202 Series	Emergency Vents	MH25724
301 Series	Emergency Vents	MH25724
61f STOP	AST Overfill Valve	MH25724
200TG	Mechanical Tank Gauge	MH29367
44TA-LLFS	Liquid-Level Float Switch Sub Assembly	E177423
X44TA-0100	Liquid-Level and Overfill Alarm	ETL302278-H01

UL-Listed for Canada and ULc - Aboveground Products

Product	Description	File #
11A Series & Astro	Automatic Nozzle	MH1942
11B Series & AstroB	Pressure-Sensing Automatic Nozzle	MH1942
1A Nozzle	Automatic Nozzle	MH1942
7H Series	Automatic Nozzle	MH1942
7HB Series	Pressure-Sensing Automatic Nozzle	MH1942
44 & 44N	Flow Limiters	MH8488
11AKF & 11AKPF	Farm Nozzle	MH1942
241TPS	Two-Plane Swivel	MH4542
20S	Hose Swivel	MH4542
45	Hose Swivel	MH4542
66SB	3/4" Swivel Breakaway	MH18037
66REC	Reconnectable Breakaway	MH18037
66RB	1" Reconnectable Breakaway	MH18037
66V	Breakaway	ULC MH27235, UL for Canada MH18037
61 fSTOP-XXXX Series	Overfill Prevention Valve	MH25724
61 fSTOP-XXXXT Series	Overfill Prevention Valve	MH25724
6211 Series	Remote-Fill AST Spill Containers	MH27236
6221 Series	Direct-Fill AST Spill Containers	MH27236
331 / 332 Series	AST Spill Containers	MH19391

MoPETP (Missouri Performance Evaluation Testing Procedures)

11VF-47	Balance Nozzle	MoPETP 99-03
66CL/CSU/CLP	Coaxial Breakaway	MoPETP 99-03
523V	Pressure/Vacuum Vent	APCP-0002-001-99
62M	Monitoring Cap	MOPETP APCP-0002-001-99

Florida

211AST, 211 REMOTE, 221AST	AST Spill Containers	EQ-226
61 fSTOP Series	AST Overfill Prevention Valve	EQ-225

New York City Fire Department Certification Number

61 fStop	AST Overfill Prevention Valve	4949
----------	-------------------------------	------

Other VaporSaver Approvals

ATEX – SIRA 03ATEX 9535	Texas ORVR Certification Approval Letter: 12/01/04
TUV – 97-11.1	Mexico – SEGEMDGPCCAT- MTSRV- DOVER/001/2004
Independent 3rd Party Certified C-030501	Japan – KHK File# 16-4-5
MDE Regulation Chapter 02.03 c(5)b	

OPW Instruction Manuals

Description	Part Number	Description	Part Number
Access Pipe Installation Instructions.....	API-0001	1 TAG.....	H13773M
California Compliant Boot Info Flyer.....	CAB-0001	1-2100-DSH Shell/Fibrelite Spill Container.....	H15324PA
California Compliant Pipe Info Flyer.....	CPF-0001	1-3100 Series Double Wall Spill Container.....	202181
Coax Fitting Flyer.....	CFF-0001	1-3100-TOOL.....	202395
Cold Weather Flyer.....	CWF-0001	10 Plus Emergency Valve.....	201614
Coupling Machine Operating Instructions.....	CMI-0001	10 Series.....	H11374PA
Dispenser Containment Flyer.....	DCF-0001	10 Series 2".....	H11442M
Dispenser Containment Manual.....	DCM-0001	100 Series Counterweight Hose Retractors.....	H15852PA
Dispenser Pans and Entry Fitting Install.....	DPI-0001	101BG Slip On.....	H12579M
Dispenser Sumps & Stabilizer Bars.....	DSI-0001	101BG-2100.....	H12260M
Double Entry Boot Flyer.....	DBF-0001	101BG-21AR Spacer Ring.....	H12713PA
Entry Boot Flyer.....	EBF-0001	101BG-LATCH.....	H13533M
E-Vac Installation Instructions.....	EII-0001	104AOW Observation Well.....	H12892M
Flexible Entry Boot Manual.....	EBM-0001	104AOW-12KIT.....	H14490M
Flexible Entry Boots.....	FBI-0001	10R Replacement Top.....	H09683PA
Flexible Isolation Tubes.....	P-ITI-5080	144TA and 444TA-0100.....	200655
Flexible Piping Manual.....	UPM-0001	18KR RACK KIT.....	H10150PA
Float Vent Valve Install.....	FVV-0001	18KVA Rack Kit.....	H13156M
Install Tips.....	FIT-0001	199ASV Series.....	H13422PA
PetroTrip Flyer.....	PTF-0001	1DK-2100 Drain Valve Kit.....	H11471M
Petro-Trip Installation.....	PTI-0001	1DP Drain Plug Kit.....	H15199M
Pipe Cutaway Flyer.....	FPC-0001	200TG Tank Gauges.....	H14912PA
Piping Flyer.....	FPF-0001	201 Series.....	H14271PA
Piping Installation Instructions.....	PII-0001	202 Series.....	H11792M
SB-989 Testing Procedures.....	P-SB-989	233's and 53VML's.....	H14111M
Swivel Fitting Flyer.....	SFF-0001	295SRK.....	H9775PA
Tank Fitting Adaptor.....	FAI-0001	30MV-KIT.....	200172
Tank Sump Flyer.....	TSF-0001	505 Multiport.....	H15225PA
Tank Sump Manual.....	TSM-0001	523V.....	H11972M
Transition Sump Flyer.....	SFT-0001	523V 3" Water Column.....	H12988M
1 Spill Container Slip-on Models.....	H12262M	53VML/30MV.....	H14111PA
1-2100 Series Spill Container.....	H12295M	60V.....	H12133M

OPW Instruction Manuals

Description	Part Number	Description	Part Number
60VS.....	H12291M	634TTM-7087.....	H10772PA
61FSTOP-1000, 100M, 200M.....	H12676M	6521-XAR Adaptor Ring.....	201526
61FSTOP-2000.....	H13337M	6591B Container.....	H16047PA
61FSTOP-3000, 3050, 305A.....	H13315M	6591B Series.....	H16043PA
61FT-0312, 0206.....	H14428PA	68EZR Reconnectable Breakaway.....	208080
61JSK.....	H15289M	70 and 70S Verticle Check Valve.....	H11055PA
61JSK-4410 AND 61JSK-44CB.....	H15289M	7150.....	H15524PA
61JSK-4RMT.....	H14741PA	700 Series Remote Replaceable.....	200242
61SOM EVR.....	H15057PA	700 Series Replaceable Spill.....	200219
61SA-TOOL.....	H14991PA	82RV-2505 Series Pressure Relief Valve Instruction Sheet.....	200517
61SALP.....	H12712M	CPN PIPE - POLYWRAP REMOVAL.....	200453
61SO Methanol Lower Tube Instructions.....	C04098M	Extractor Fittling 233E Style, 233VP, 233 VMP Test Caps	H11223PA
61SO-4000 Series.....	H11764M	MPWS.....	H15226PA
61SO-4BYT.....	H12027M	MPWS-33TS.....	H15912PA
61SOC Coaxial Fill Tube.....	C03634PA	MPWS.....	H15861PA
61SOK Float Kit.....	H11403PA	MSDS Sheet For Loctite "Weld"	H12854M
61SOM EVR.....	H14790M	211-RMOT Remote Fill Aboveground Storage Tank Spill Container.....	H15857PA
61SOR Remote Fill Tube.....	H11964M	211, 221-AST Direct Fill Aboveground Storage Tank Spill Containers.....	H15854PA
61T Drop Tube.....	200652	H15854PA
61T-2" Drop Tube.....	H15392PA	6111-KP Slip On Series Spill Container with Hand Pump Instruction Sheet.....	H15850PA
61TCP-3800.....	H12064M	7111SS-CSDW Double Wall Slip On Series Spill Container Instruction Sheet.....	200639
61TNG.....	H12697M	Island Form Instruction Sheet	H15851PA
61TP-2398.....	H09787PA	Pump Kit 1P-2105.....	H12302M
61VSA.....	H14656M	Registration Card.....	H15003PA
1611 - 3" Vapor Adaptor.....	H08843PA	Threaded Carb Approved (61SOP).....	H13792M
6111-1400.....	H14977M	Threaded/Carb Approved (61SO).....	H13791M
6111-1400 Tank Bottom Protector.....	H14977PA		
6211-AST and 6221-AST Spill Containers.....	202207		
623V.....	H15208M		
623V.....	H14898M		
62M Series.....	H14491PA		
633TC & 633TCP.....	H10013PA		

OPW Instruction Manuals

Description	Part Number	Description	Part Number
100 Series Counterweight Hose Retractors.....	H15852PA	190 Upper Poppet Replacement Inst. Sheet.....	H10969PA
102 Spring Balance Hose Retractors.....	H15853PA	295 Guard Replacement Kit Instruction Sheet.....	H14519M
11A Spout Replacement Kit Inst. Sheet, Canada.....	H15177PA	295 Series Instruction Sheet.....	H09237PA
11A, 11B, 7H Nozzles Canada.....	H15987M	295 Swivel Repair Kit Instruction Sheet.....	H15904PA
11A, 11B, 7H Nozzles USA.....	H15985M	3VW VEG Kit (Wayne Models) Instruction Sheet...H12172M	
11B Spout Replacement Kit Inst. Sheet, Canada... H15178PA		44 Series Instruction Sheet.....	H12918PA
11VA & 11VAI Series Instruction Sheet.....	H13664M	44N Series Instruction Sheet.....	H13168PA
11VA Hand Insulator Kit Instruction Sheet.....	H11935PA	5B Leaded Spout Kit Instruction Sheet.....	H10426PA
11VA Spout Replacement Kit Instruction Sheet....	H13938M	5B Series 11A, 11B Spout Kit Instruction Sheet....	H04872M
11VAA Series Instruction Sheet.....	H13234M	5BH Series 7H, 7HB Spout Kit Instruction Sheet...H08336PA	
11VAI Spout Repl. Kit w/ Adap. Inst. Sheet.....	H12686M	5D Series 1290 Spout Kit Instruction Sheet.....	H09656PA
11VAI Spout Repl. Kit w/o Adap. Inst. Sheet.....	H12881M	66CAS, 66TEC, 66FLB Series Instruction Sheet....	H13008M
11VAI Vapor Path Rep. Kit Instruction Sheet.....	H13142M	66CL Series Instruction Sheet.....	H11487PA
11VAI, 12VW Vapor Recovery Nozzles.....	H15986M	66CLP Breakaway.....	F-70
11VF Balance Nozzle.....	H10655PA	66CSU Breakaway.....	F-72
11VF Balance Nozzle.....	H14380M	66ISB Swivel Break.....	F-68
11VF Bellows & Face Seal Rep. Kit Inst. Sheet....	H11011PA	66ISU Breakaway.....	F-71
11VF Bellows Replacement Kit Instruction Sheet...H11010PA		66SB/RB.....	F-69
11VF Face Seal Replacement Kit Inst. Sheet.....	H11009PA	66SRK-1000 O-ring kit (66CAS).....	H14485PA
11VF Hand Insulator Instruction Sheet.....	H10791PA	OPW Hand Insulators.....	H11337PA
11VF Spout Replacement Kit Instruction Sheet....	H11007PA	Renewable Hand Insulators.....	H10652PA
11VF Spout, Bellows, & Face Seal Repl. Kit Inst. .H11008PA		RTC – RTR Covers and Rings and replacement gasket for the RTC.....	H15187M
1290 Automatic Bulk Nozzle.....	H09238PA		
12VW Hand Insulator Repl. Kit Instruction Sheet...H14604PA			
12VW Series Instruction Sheet.....	H14072M		
12VW Spout Replacement Kit Instruction Sheet..H14603PA			



Global Operations

- 1 OPW Retail Fueling**
 HWY 70 Business West
 Smithfield, NC 27577, USA
 Tel: (919) 934-2786
 Fax: +1 (919) 359-3687
 Customer Service:
 1(800) 422-2525
 Customer Service Fax:
 1(800) 421-3297
 www.opwglobal.com
- 2 OPW Mexico**
 Homero 136 Int. 403
 Col. Chapultepec Morales
 México DF CP 11570
 Delegación Miguel Hidalgo
 Tel: 52 55 5254-5672
 aanguiano@opw-fc.com
- 3 OPW EMEA KPS**
 OPW Sweden AB
 Fabrikgatan 3
 Box 70
 S-736 22
 Kungsör, Sweden
 Tel: +46 227 422 00
 Fax: +46 227 422 01
 www.opwglobal.com/emea
- 4 OPW India**
 Dover India Pvt Ltd.
 OPW Fueling Components Div.
 A-93 , Wagle Industrial Estate
 Thane 400 604
 Maharashtra, India
 Tel: 91 22 6710 0812,13,14
 Fax: 91 22 6710 0815
 info@opwfc-in.com
- 5 OPW Asia Pacific**
 No.11 Weiwen Road
 Suzhou Industrial Park
 Suzhou, P.R.C. 215122
 Tel: 86-(0)512-6274-5328
 Fax: 86-(0)512-6274-5338
 info@opw-fc.com.cn
 www.opw-fc.com.cn
- 6 Liquip**
 13 Hume Road, Smithfield
 Sydney NSW Australia 2164
 PO Box 7049
 Wetherill Park BC 2164
- 7 OPW EMEA/Fibrelite**
 Snaygill Industrial Estate
 Keighley Road, Skipton
 North Yorkshire
 BD23 2QR
 UK
 Tel: + 44 (0) 1756 799 773
 Fax: + 44 (0)1756 799 539
 covers@fibrelite.com
- 8 OPW Brazil**
 Wayne Industria E Comercio
 Estrada Do Timbo 126
 Bonsucesso
 Rio De Janeiro, RJ 21061280
 Tel: +55 21 3725 8604
 www.opwbrasil.com.br
- 9 OPW Malaysia**
 Lot P.T. 27259, Jalan Sigma U6/14
 Bukit Cerakah, Seksyen U6
 40150 Shah Alam
 Selangor Darul Ehsan, Malaysia
 Tel: +6 03 – 7770 1000
 Fax: +6 03 – 7770 1010



OPW STANDARD PRODUCT WARRANTY

NOTICE: FlexWorks by OPW, Inc., VAPORSAVER™ and all other OPW products must be used in compliance with all applicable federal, state, provincial and local laws, rules and regulations. Product selection is the sole responsibility of the customer and/or its agents and must be based on physical specifications and limitations, compatibility with the environment and material to be handled. All illustrations and specifications in this literature are based on the latest production information available at the time of publication. Prices, materials and specifications are subject to change at any time, and models may be discontinued at any time, in either case, without notice or obligation.

OPW warrants solely to its customer (the initial purchaser and any subsequent purchasers within the warranty period) that the following products sold by OPW will be free from defects in materials and workmanship under normal use and conditions for the periods indicated:

PRODUCT	WARRANTY PERIOD
FlexWorks Primary Pipe	10 years from date of manufacture
All Products and replacement parts installed in the State of California Certified to California CP-201 and/or CP-206 Standards*	1 year from date of installation (proof of purchase from certified contractors/technicians required) OPW warrants ongoing compliance with the standards and specifications for the duration of the warranty period required by the State of California; this limited warranty is under the condition the equipment was installed and maintained by trained and certified contractors/technicians unless noted in Installation Manual
All Other Products	1 year from date of manufacture
*Products certified to California CP-201 and/or CP-206 Standards have been factory tested and met all applicable performance standards and specifications and will have an OPW registration card enclosed/attached to the product	

OPW's exclusive obligation under this limited warranty is, at its option, to repair, replace or issue credit (in an amount not to exceed the list price for the product) for future orders for any product that may prove defective within the applicable warranty period (repairs or replacements are subject to prorated warranty coverage for remainder of the original warranty period). Complete and proper warranty claim documentation and proof of purchase required. All warranty claims must be made in writing and delivered during the applicable warranty period to OPW at OPW 9393 Princeton-Glendale Road Hamilton, Ohio, USA 45011, Attention: Customer Service Manager. No products may be returned to OPW without its prior written authority.

This limited warranty shall not apply to any FlexWorks or VAPORSAVER™ product unless it is installed by an OPW attested installer. This limited warranty also shall not apply to any FlexWorks, VAPORSAVER™ or other OPW product: unless all required site and warranty registration forms are completed and received by OPW within 60 days of installation; unless all piping connections are installed with a nationally recognized or state-approved leak-detection device in each tank and dispenser sump (which are not for storage and from which all discharge hydrocarbons must be removed, and the systems completely cleaned, within 24 hours); unless testable sumps utilize FlexWorks pipe and access fittings; unless a sump inspection log or an EPA-recommended/required checklist is maintained and the results are furnished to OPW upon request; and unless OPW is notified within 24 hours of any known or suspected product failure and is provided with unrestricted access to the product and the site. This limited warranty also shall not apply to any product which has been altered in any way, which has been repaired by anyone other than a service representative authorized by OPW, or when failure or defect is due to: improper installation or maintenance (including, without limitation, failure to follow FlexWorks Quick Reference Manual Installation Guide and all product warning labels); abuse or misuse; violation of health or safety requirements; use of another manufacturer's, or otherwise unauthorized, substances or components; soil or other surface or subsurface conditions; or fire, flood, storm, lightning, earthquake, accident or any other conditions, events or circumstances beyond OPW's control.

THIS LIMITED WARRANTY IS IN LIEU OF ALL OTHER WARRANTIES, EXPRESS OR IMPLIED, AND ALL OTHER WARRANTIES INCLUDING, WITHOUT LIMITATION, THE WARRANTIES OF MERCHANTABILITY AND FITNESS FOR A PARTICULAR PURPOSE, ARE HEREBY EXCLUDED.

OPW shall have no other liability whatsoever, whether based on breach of contract, negligence, gross negligence, strict liability or any other claim, including, without limitation, for special, incidental, consequential or exemplary damages or for the cost of labor, freight, excavation, clean-up, downtime, removal, re-installation, loss of profit, or any other cost or charges. No person or entity is authorized to assume on behalf of OPW any liability beyond this limited warranty. This limited warranty is not assignable.



Underground Products
Aboveground Products
CleanEnergy Fueling Products

OPW 
RETAIL FUELING
a **DOVER** company